

Medical Waste Incinerator

- * the incinerator
- * various models
- * **construction**
- * operating
- * experiences
- * contact

Construction

De Montfort University Incinerator	Mark I Model
De Montfort University Incinerator	Mark III Model
De Montfort University Incinerator	Mark VII Model
De Montfort University Incinerator	Mark VIIIA Model
De Montfort University Incinerator	Mark IX Model

DISCLAIMER

Since the safe and successful use of the incinerator, which operates at very high temperatures, is entirely dependent on the building, operation and maintenance thereof, the University and the organisations supplying the drawings and instructions can bear no responsibility for any mishaps to personnel or inadequate technical performance of the incinerator.

De Montfort University Incinerator Basic (*Mark I*) Model Building the Incinerator

Note that all dimensions are approximate and may be varied to suit the materials (particularly the firebricks) available.

1. Select the site, which should preferably be away from buildings, and ensure that it is level and solid. If there is any doubt of its solidity, a reinforced concrete base 100mm thick should be laid over an area of 2m x 1.5m.

2. Lay out a base of firebricks 36 inches by 24 inches (900mm x 600mm approx.)

3. Build the firebrick core as in Figure1. At this stage, the fire door tunnel and the air inlet tubes should be added. The fire door tunnel is to fit the fire door and frame, which may be obtained commercially or made for the purpose. The approximate dimensions of the fire door and tunnel should be 230 x 230mm by 34mm (3 brick widths) long.

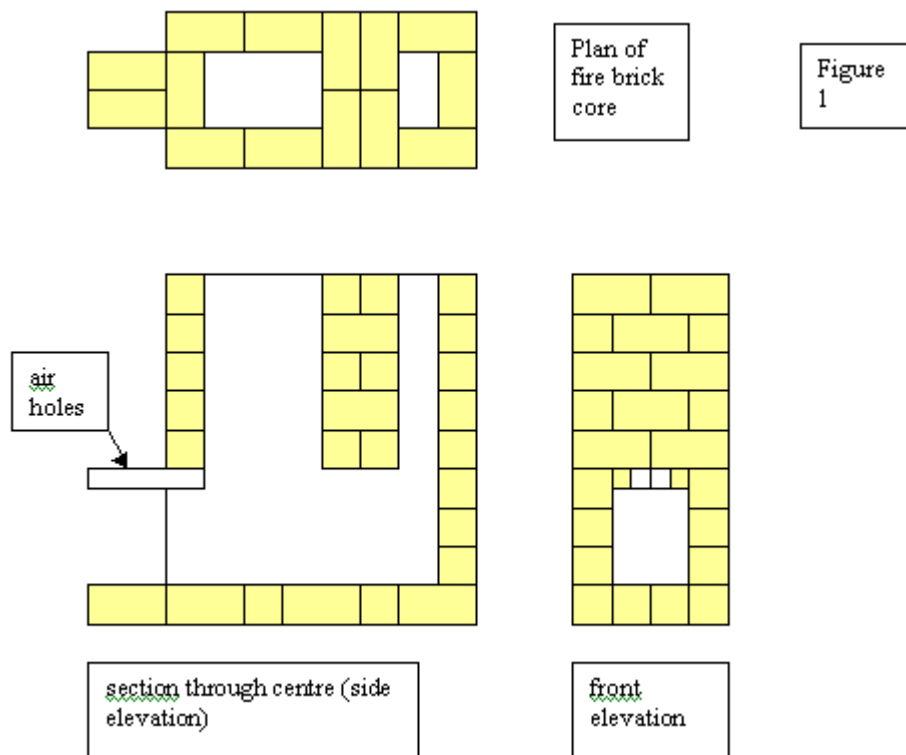

4. Secure the firebrick core by binding 4 lengths of mild steel angle, one to each corner as in Figure 2. The binding may be by steel cable tightened by a turnbuckle arrangement, or by steel bars with screwed ends. One strap should be at the top layer of bricks, one at the center, and one at the base layer. Note that if the available firebricks are of irregular shape, the firebrick core may be built using high alumina fire cement, in which case no binding is necessary.

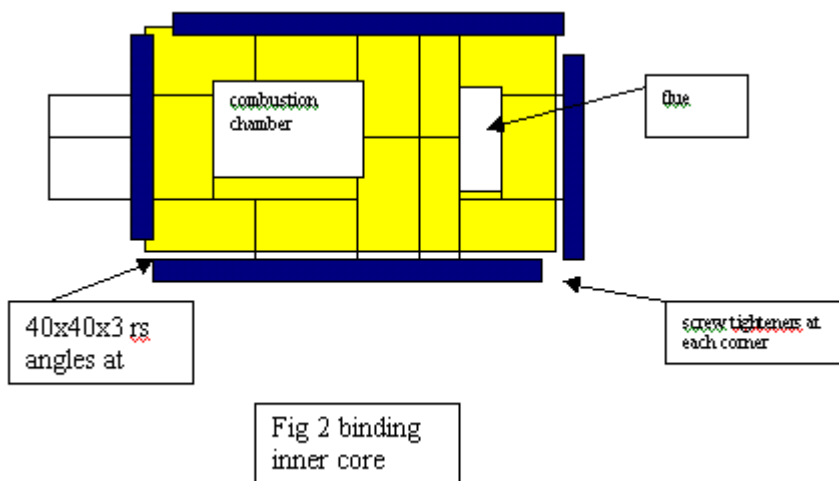

5. Lay out a single layer of common bricks around the whole construction, allowing space for mortar between the bricks, and about one brick thickness between the common bricks and the firebrick core. The outer dimensions of the incinerator can now be measured so that a start can be made on the steel top plate.

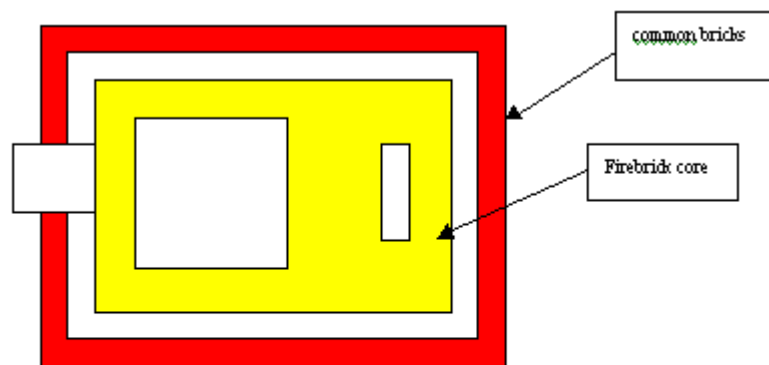

Figure 3 Outline of brick outer casing

6. Build up the brick outer case using ordinary mortar between bricks, and taking care to keep to the measured dimensions. The final height of the outer case must match the inner core, but final adjustment can be made with mortar when the top plate is fitted

7. Check that cut outs in top plate match the combustion chamber and flue. Then make and attach the sand seals and stiffeners as shown in Figure 4. All frames should be made from 40x40x3 rolled steel angle, and attachment may be either by welding or riveting. The chimney spigot should be made to suit the chimney available, which can be a steel tube of a minimum diameter 100mm. and 3m long.

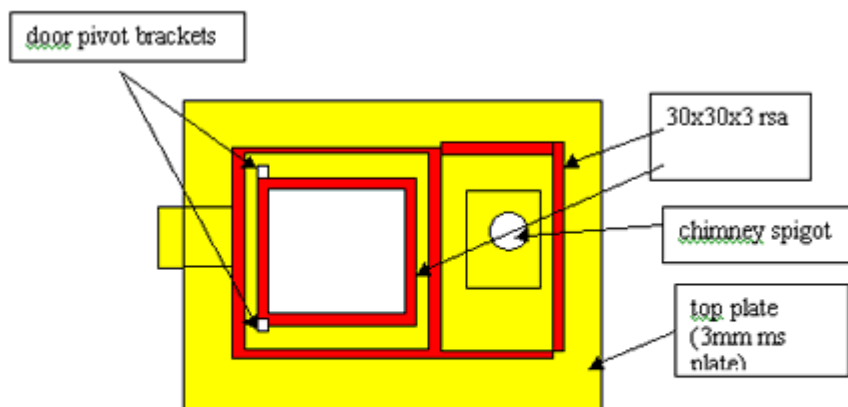

Figure 4 Sand frames of rolled steel angle fitted to top plate

8. The loading door can now be made as in figure 5. The angles should fit into the spaces between the sand frames to make an air-tight seal. A vertical handle attached at the pivot end of the door will make opening and closing easier.

9. Make the top plate holding frame from 40x40x3 rsa as in Figure 6. This should fit over the brick outer casing and hold down the top plate while allowing the top plate to expand with temperature. Fire cement should be used to seal any gap between the firebrick and the top plate, and Portland cement or fire cement to seal the gap between the outer casing and the top plate.



10. The top plate can then be held down by the holding plate, with screws securing the side plates to the brickwork,

11. Drill through the top layers of bricks of both inner and outer casings with a 6mm masonry drill, and insert the pipe for diesel fuel addition. (diesel fuel model only) Attach fuel tank to outside of casing about 500mm above the top of the incinerator, and lead a fuel line via a tap into the combustion chamber, protruding into the chamber by about 10 mm. The fuel tank should be at least 1 metre to the side of the incinerator casing.

12. Erect chimney over chimney spigot and secure against lateral movement. Steel cables are recommended.

13. Attach a hinged ash door to the front of the ash hole. This door can be made from steel plate, and should be able to be latched in the closed position when the incinerator is in use.

14. Make from 30x30x3 rsa a grate to fit in the bottom of the combustion chamber. This should have 100mm legs and 4 cross members as shown in figure 7.

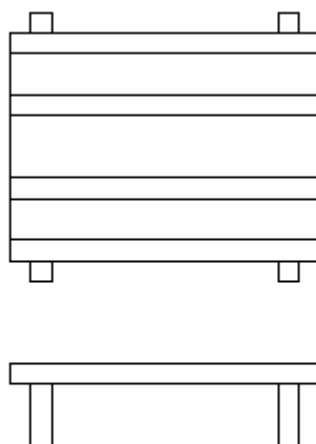
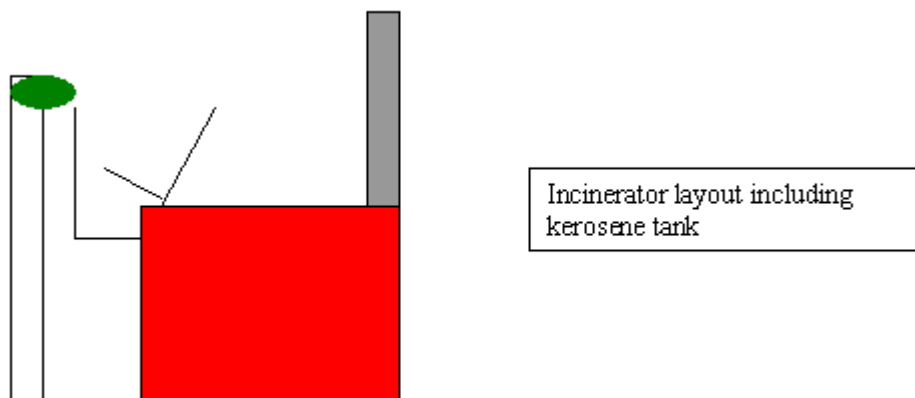

Figure 7. grate (30x30x3 rsa)

15. Attach loading door with a pivot to the loading door frame, and fill the seal area and the area round the chimney spigot with soft dry sand.



Materials List

Item	Description	Size	Quantity
1	Firebricks	230x116x76mm (approx)	156
2	Standard building bricks	230x116x76mm (approx)	220
3	Portland cement	25kg per bag	3 bags
4	Sand	25kg per bag	300kg

5	Fire cement (1300 ⁰ C+)		1 bag (3 bags if inner core is mortared)
		75x50x3mm	
6	U section mild steel	75x40x3mm wall thickness	4 metres
7	Rectangular section m.s.	50x50x3mm thick	3 metres
8	Angle section m.s.	12 mm inside diameter	30 metres
9	Water tube m.s.	2400x1200x2mm	3 metres
10	Flat sheet m.s	120mm dia,x4mm thick (approx)	1 sheet
11	Steel pipe.		4 metres
		2400x1200x1.2mm	
12	Flat sheet m.s.		2 sheets
13	(only needed if chimney is to be fabricated on site)	10 mmx75 mm long	
14			24
15	Bolts	8 mmx50 mm long	24
16	Bolts	10 mm	24
17	Nuts	8mm	24
18	Nuts	10 mm	24
19	Washers	8 mm	24
20	Washers	No.8x50 mm long	20
21	Screws	Mild steel	60
22	Welding rods	2 litres capacity, minimum	1
23	Fuel tank	4 metres	1
24	fuel tap (to fit fuel tank)		1
	fuel pipe 5mm Dia. (approx)		1

[go back up](#)

**De Montfort University Incinerator (*Mark III*) Model
Building the Incinerator**

[\(click here for a visual presentation of an installation\)](#)

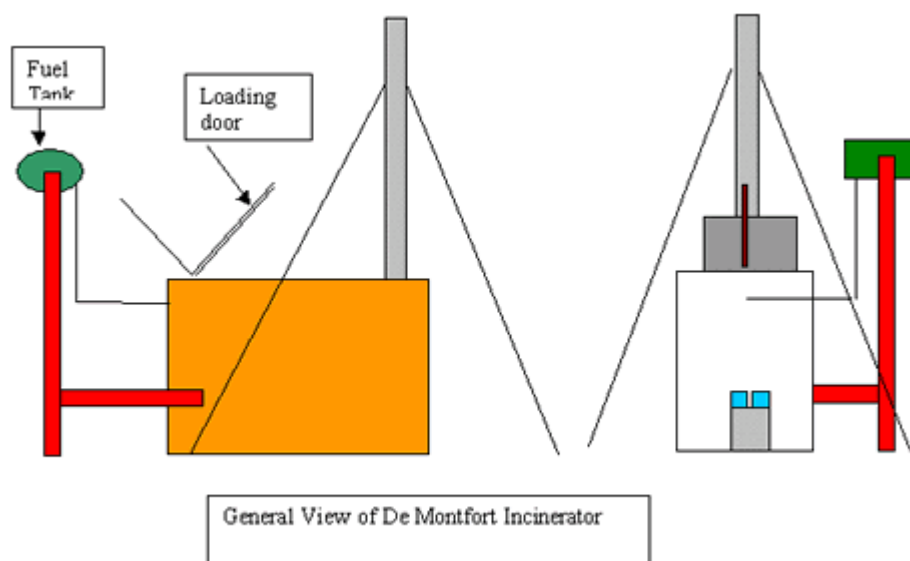

1. Select the site and ensure that it is level for 3mx2m
2. Lay out the base in firebricks as in the diagram 1. The diagram is based on UK standard firebricks (9x4.5x2.5 inches) and is approximately 54 inches (1370mm) long by 27 inches (686mm) wide. For any other size of firebrick, make up the nearest possible overall dimensions.

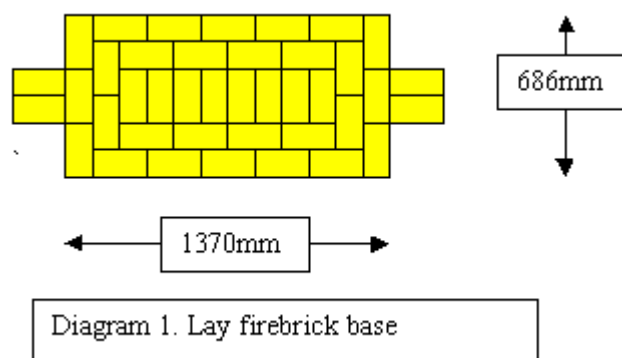

3. Build the firebrick inner core as in diagram 2. Again, with UK bricks there are 14 layers of bricks including the base, giving an approximate height of 35 inches (900mm). With any other size of brick, build to at least this height. A steel tunnel to fit the ash door frame (230mm approx.) is incorporated at either end as in diagram stage 2, and air pipes to give an air intake area of about 6200 mm² are built in at the primary combustion chamber end. Air pipes of about 1000mm² are built in at the other end. Note that no mortar or fireclay is used in this construction, if the firebricks are regular in shape. Fire cement (3:1 mixture of high alumina cement and sand) may be used if the firebricks will not meet without air gaps.

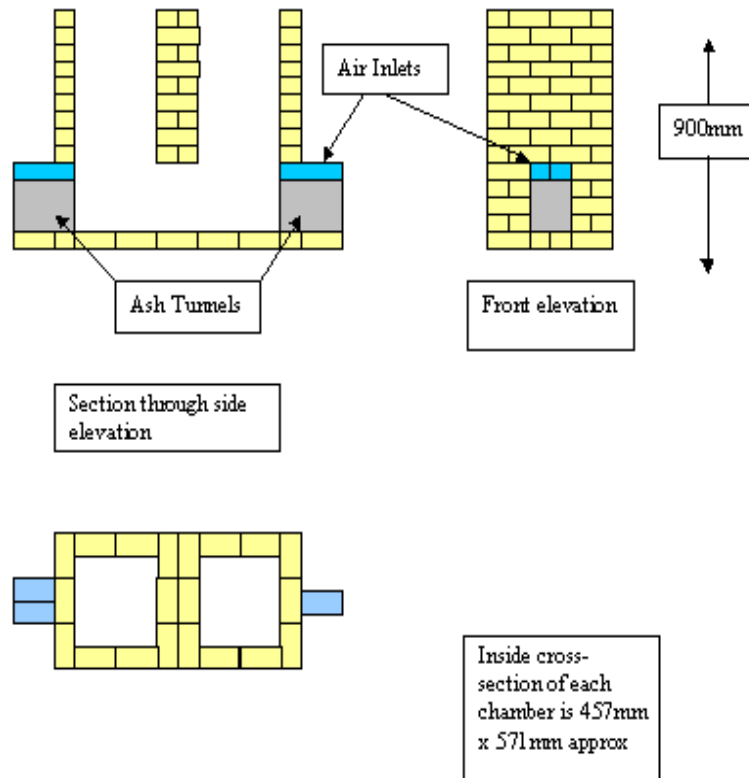
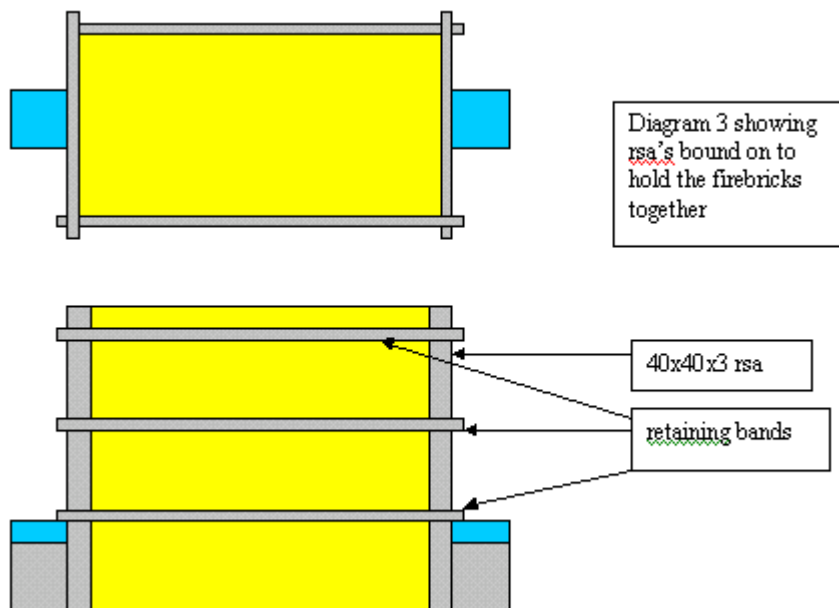

diagram 2 : Construct Firebrick core

4. Fit 4 lengths of rolled steel angles (40x40x3 approx), one along each corner of the firebrick construction, and tightly strap them together to force the firebricks together as in Diagram 3. The strap may be either steel cable tightened by a turnbuckle arrangement or steel bars with screwed ends. One strap should be at the top layer of bricks, one at the centre, and one at the base layer. This step may be omitted if fire cement has been used.



5. Lay out a single layer of common bricks around the whole construction, allowing space for mortar between the bricks, and about one brick thickness between the common bricks and the firebrick core. The outer dimensions of the incinerator can now be measured so that a start can be made on the steel top plate.

6. Build up the outer frame using ordinary building mortar, and taking care to keep to the measured dimensions. The final height of the outer case must match the inner core, but final adjustment can be made with mortar and/or fire cement when the top plate is fitted. (Diagram 4)

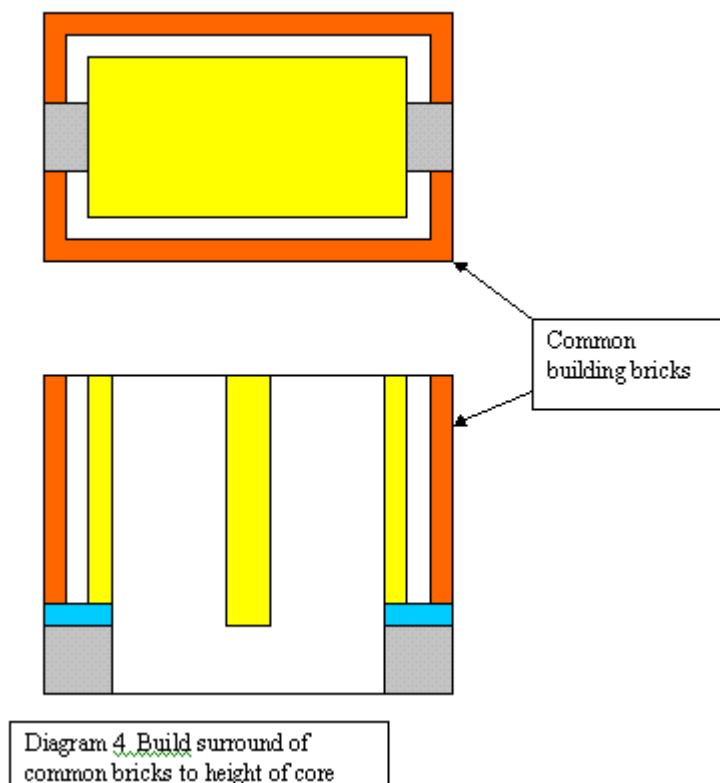

7. Mark out the steel top sheet as in diagram 5. The length and the width should each be 20mm less than the corresponding length and width of the brick surround. The circular cutout for the chimney should be slightly less than the chimney inner diameter. There is considerable latitude in the chimney diameter, which can be between 100 and 150 mm. It is thus necessary to choose the chimney before cutting the hole. Note that the loading door hole should be the cross section of the combustion chamber, and that both the chimney hole and the smoke door hole should be within the secondary chamber.

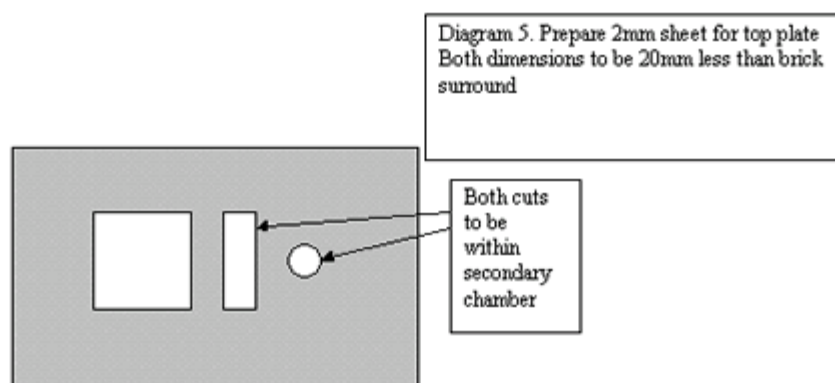

8. Rolled steel angle (rsa) of approximate size 40x40x5mm is now attached to the top plate as in diagram 6. These are intended to provide a frame for a sand bed around both doors and the chimney spigot. The inner frames are around the door apertures, and the outer frame is about 70mm further out. Note that the outer frame of the loading

door carries the brackets for the door pivot. The centre brace is about 80mm shorter than the width of the top plate. Attachment may be by welding or steel rivets. Rolled steel angle stiffeners are then attached to the underside of the top plate as in diagram 6a.

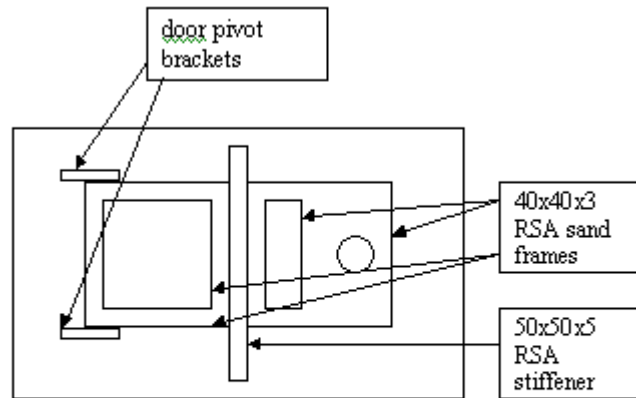

Diagram 6. Add sand frame and stiffener to top plate

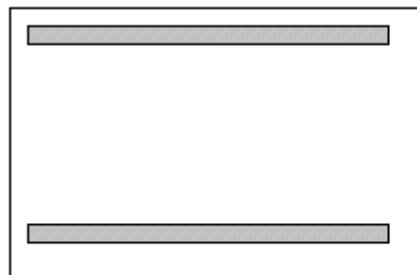

Diagram 6a RSA stiffeners fitted to underside of top plate

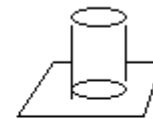
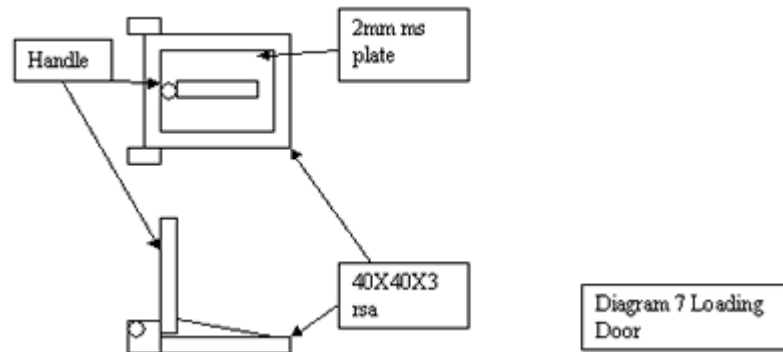
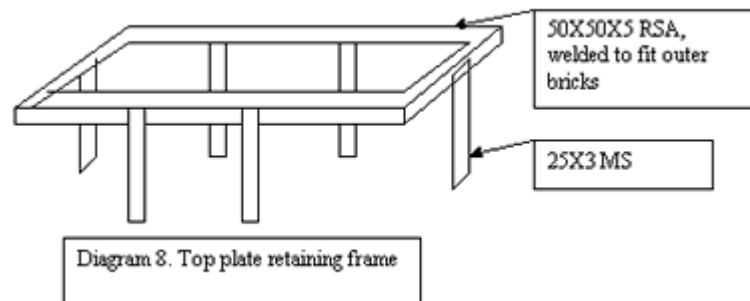

Diagram 6b chimney spigot

9. The loading door can be made at the same time (diagram 7). The frame is made from 40x40x5 rolled steel angle, and the size adjusted so that the lower edge of the angle fits into the centre of the sand bed of the frame. The hinge support brackets on both the door and the frame can be made so that the door rests parallel with the frame when suspended (by sand) about 10mm above the base of the channel. The door is completed by welding or riveting on a top of 2mm plate, and attaching a handle at the pivot end to make opening and closing easier. The handle should be about 450mm long.



10. The steel top is then fitted over the brick construction in the following manner. A layer of fire cement is laid on to the firebrick inner core. The top plate is then placed on top and manoeuvred so that it sits firmly on the cement over the whole surface. Ordinary mortar or fire cement can then be pushed between the top plate and the outer bricks to make a seal.



11. The steel top is now secured to the brick walls by the steel frame shown in diagram 8. This is designed to pull the top plate down to the bricks, with sufficient mortar and/or fire clay to make sure that the plate fits evenly on both the inner and outer walls.

12. Ash doors can now be made from steel plate to hinge on to the ash tunnels. These doors should be latched closed when they are not being used to remove ash.

13. The 4 metre steel chimney can now be fitted over the spigot and secured by steel ties reaching either to the ground or to the sides of the outer case.

14. For the oil fired version, a fuel tank with a capacity of between 2 and 5 litres should be fitted to the front of the incinerator at approximately 500mm above the top of the incinerator. A 6mm hole should be drilled through both walls of the combustion chamber, and a steel tube inserted to project about 10mm into the chamber to carry fuel from the tank via a simple on/off tap.

15. The secondary combustion chamber should be loosely filled with wire mesh. This will serve to stabilize secondary combustion, and prevent any light solids reaching the chimney stack.

16. Fine dry sand can now be placed in the loading door frame and the sand seal for the smoke door and chimney.

17. A simple grate should be made to fit below the primary combustion chamber. It is constructed of 40x40x3 rsa, with the gaps between the grids not less than 50mm. The legs should be 80mm long. This should be inserted from above through the fire door.

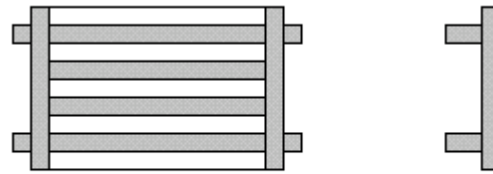

Diagram 9 Fire grate

[go back up](#)

De Montfort University Incinerator (*Mark VII*) Model Building the Incinerator

[\(click here for a visual presentation of an installation\)](#)

The Mark 7 ('Flat pack') Incinerator

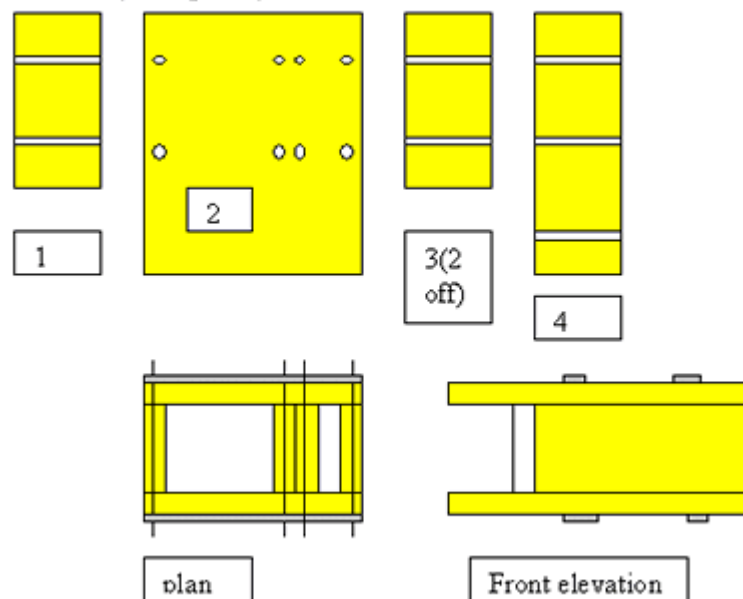

De Montfort Incinerator Mark 7 (flat pack)
Figure 1

The incinerator body is constructed from 5 concrete flat castings held together by nuts, bolts and steel straps. The incinerator roof and the loading door are fabricated from 3mm mild steel sheet with reinforcements. Any gaps between concrete castings are sealed with fireclay. The loading door frame is built into the top panel and the ash door frame and the air pipes onto the front panel. The chimney stack is made from thin stainless steel chimney liner supported on an angle steel frame bolted to the rear panel. Each concrete panel is made from an inner layer of high alumina cement 15mm thick, and an outer layer of insulating cement made from a mixture of vermiculite and Portland cement 75mm thick. A reinforcing mesh is cast into each panel, and 20 mm

diameter steel tubes cast into the front, centre and rear panels to mate with holes cast into the two side panels. The incinerator can thus be bolted together, using 10 mm screwed rod, and the joints sealed with fire cement.

Making the panels

Each panel should be cast in a rectangular wooden former in the following manner. A 15 mm thick layer of high alumina medium density fire cement should first be cast in the bottom of the former. (For one of the two side panels, the vermiculite cement must be cast first, and the fire cement on top in order that each panel can be assembled with the fireclay on the inside) A 75 mm layer of vermiculite cement should then be cast on top of the fire cement. A reinforcing grid should be cast in the centre of the vermiculite cement, and the 20mm tubes cast in place and positioned using screwed rod pushed through holes drilled through the wooden former.

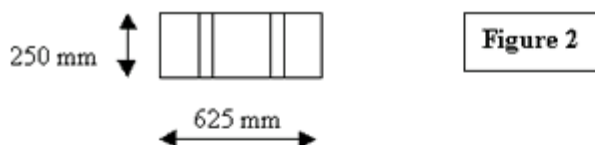

Front and two centre panels 250 mm x 625 mm
20 mm tube cast 125 mm from each end, 50 mm deep, located by rods pushed through holes drilled through the wooden former.

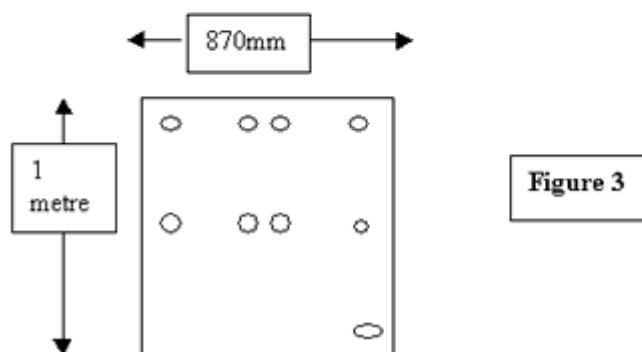

Side panels

9 off 20 mm Tubes 125mm and 500mm from top, 1 off 875 mm from top' 50 mm from sides and central, 125mm apart.



Rear panel 250 mm x 1 metre
3 off 20mm tubes cast 125mm, 500mm and 875mm from the top and 50 mm deep

Bolting Panels together

The panels are bolted together using 9 lengths of 10 mm screwed rod, each 500 mm

long passing through the cast-in tubes. Care should be taken not to over-tighten the nuts, as this could result in cracking the side panels. Strips of 30x3 mm steel are used to distribute the load along the sides of the incinerator as shown in Figure 1 and Figure 6.

Making the sand seals

These are made from 100x30x5mm rolled steel channel, welded together to make two rectangular troughs as shown on Figure 5 below. 2x 30 mm steel strip 200mm long is welded to the sides and ends of the channels to act as locating brackets when the sand seals are placed on the panels.

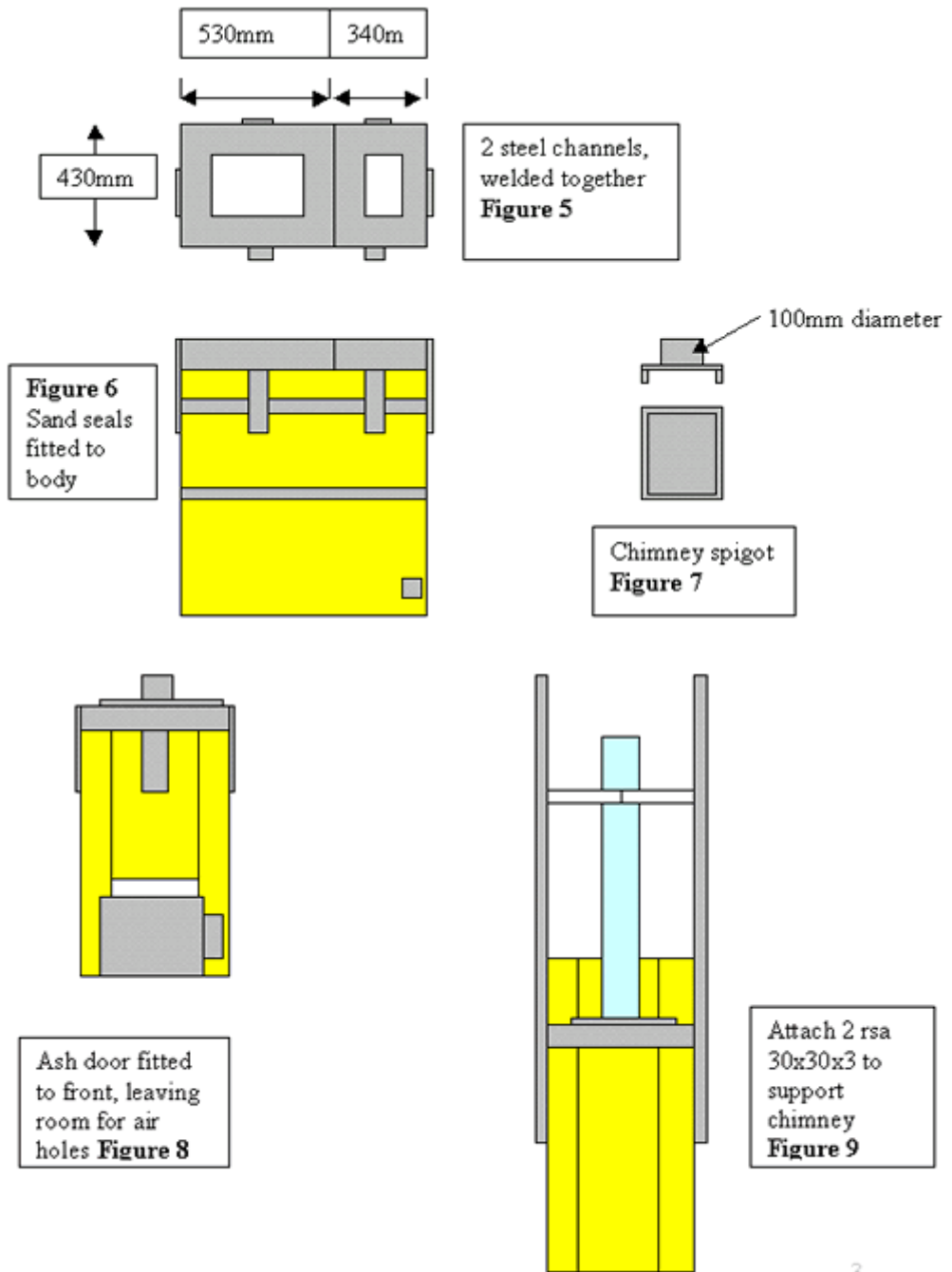

Making and Fixing the Loading Door

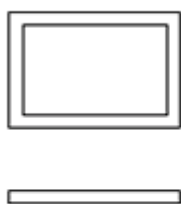

Figure 10 weld angle steel frame and attach to 3 mm ms plate

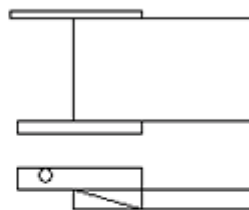

Figure 11 attach hinge brackets to door



Figure 12 Attach matching hinge brackets to door frame

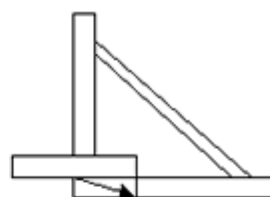

Figure 13 Attach handle to door

Attach Ash Door

The ash door is attached to the front panel by means of any suitable hinge. Both the hinge and the latch may need to be attached to a steel plate screwed to the front panel in order to give sufficient strength to the attachment.

Attach Chimney

The chimney is supplied as a 120 mm stainless steel tube, 4 metres long. it is fitted over the chimney spigot, and supported by the two rolled steel angle supports. (Note that it will not be perfectly straight). The chimney is sealed to the spigot using fire cement.

Attach Ash Door

The ash door is attached to the front panel by means of any suitable hinge. Both the hinge and the latch may need to be attached to a steel plate screwed to the front panel in order to give sufficient strength to the attachment.

Final preparation

All gaps between the panels must be sealed with fire cement. The floor must be covered with a 25 mm layer of fire cement to protect the concrete base. Firing should be delayed for 12 hours to allow initial curing of the fire cement.

Important note for Users

All manufacture except for assembly should be complete before the incinerator is delivered to site.

Parts List for "Flatpack" to be delivered to Site

1. Two matching side panels
2. Three identical panels for front and centre
3. One rear panel
4. Nine lengths of 10 mm screwed rod, with nuts and washers
5. Four lengths of 30x2mm steel strip 900mm long to distribute load from screwed rod to side panels
6. One bag fire cement (25 kg) for sealing panels and floor
7. Steel channel sand seal with hinge bracket and locating strips attached
8. Loading door with hinge bracket and handle
9. Steel hinge for loading door
10. Chimney plate and spigot
11. 4 metre stainless steel chimney
12. Two 4 metre rolled steel angles 30x30x2 for supporting chimney
13. Two chimney support brackets
14. Eighteen 5mmx25mm set screws and nuts
15. Front panel
16. Ash door with hinge, latch and securing plates
17. Twelve 10mm masonry bolts for securing plates to panels
18. Steel Grate
19. Ash Scraper

Operation

The incinerator should be started by putting waste paper, cardboard or similar easily ignited material over the grate. Burning paper can then be dropped on top, and when a good flame is established, more combustible material added till the combustion chamber is half full. If available, about 100 cc of kerosene, diesel oil or used lubricating oil can be poured on top to speed the heating process. Only dry, non-infected waste should be added for the first 30 minutes or until a fierce flame is established.

The combustion chamber should be kept at least half full, and infectious and/or wet waste should be added above dry materials to ensure that it dries before reaching the combustion zone. Additional liquid fuel can be added if it is suspected that the combustion rate is decreasing. Any plastic waste available will also help to raise the temperature of combustion, but both this and the oil will give rise to black smoke if used to excess.

The incinerator will be most efficient in fuel consumption if it is operated for fairly long periods once it is ignited, but the grate and the flue passage to the base of the chimney must be kept clear by poking a steel rod through the air inlet hole from time to time. It may also be necessary to push down the load from time to time to prevent it "arching" above the grate. The last load before closing down should be as dry and safe as possible, so that no unburned material is left on the grate.

[go back up](#)

De Montfort University Incinerator

Building the Incinerator Mark VIIIA

[\(click here for a visual presentation of an installation\)](#)

1. **The body** of the incinerator is built of firebricks
2. The plan, front elevation and cross section of the brickwork are shown in Figure 1.
3. The incinerator should be built on a 2 metre square concrete platform, with a layer of firebricks beneath the incinerator body

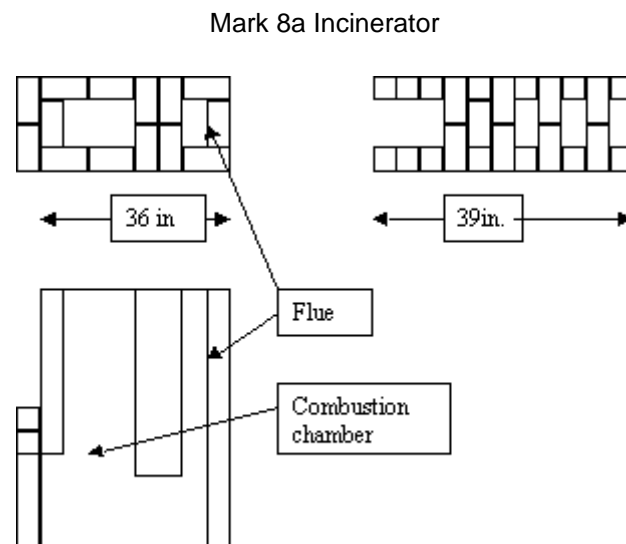

Note that the dimensions are only approximate, and may be adjusted to suit the available brick sizes. The height has not been dimensioned because discretion can be exercised over this dimension to suit the operators. It should not normally be below 36 in. (900mm)

The mortar used for the construction should be high alumina fire cement.

Two rectangular frames of 4x2x1/4in. (100x40x5) rolled steel channel are then joined together and cemented on to the bricks surrounding the top of the combustion chamber, and the bricks surrounding the flue as shown in Figure 2 below. The space within these two frames is filled with soft sand, so that the loading door (Figure 3) and the chimney spigot (Figure 4) can be closed with an air-tight seal.

Figure 2a Sand frames from mild steel channel showing locating plates and hinge brackets

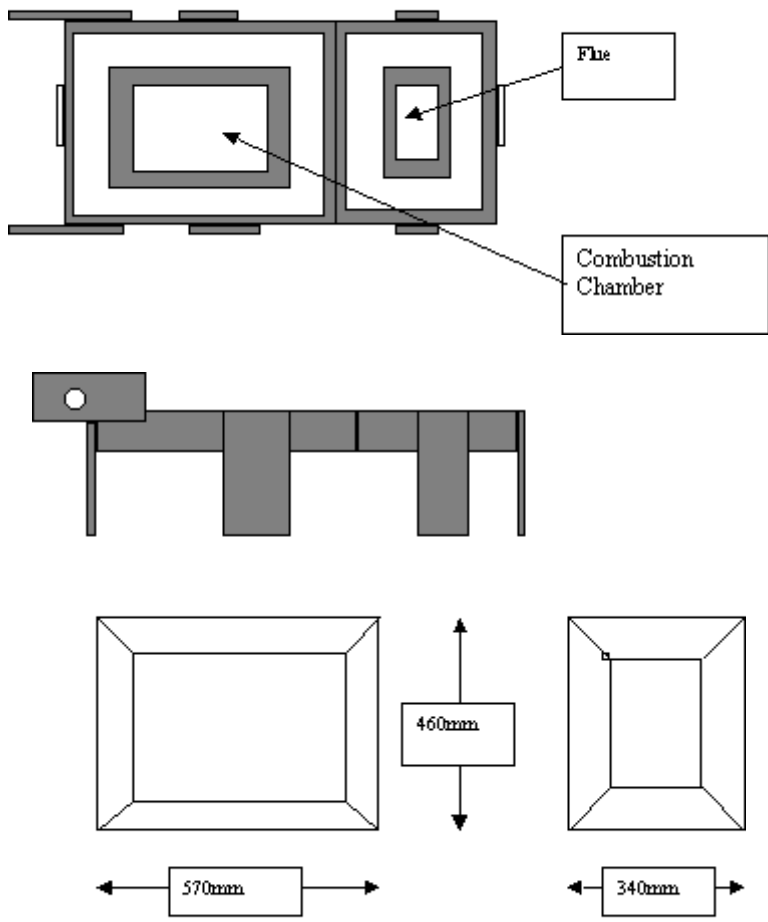

Figure 2b Dimensions of sand frames (can vary with brick dimension)

4. The loading door is made from a frame of rolled steel angle with a plate of mild steel welded to it . The frame should be made so that the protruding edges of the angle steel fit inside the channel attached to the firebricks. The door is shown in Figure 3 below. In use it is sealed by a layer of sand.

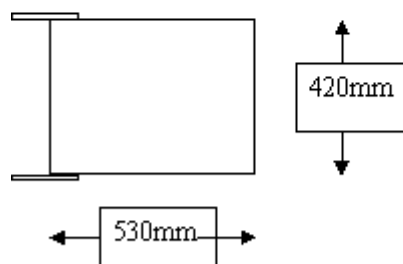
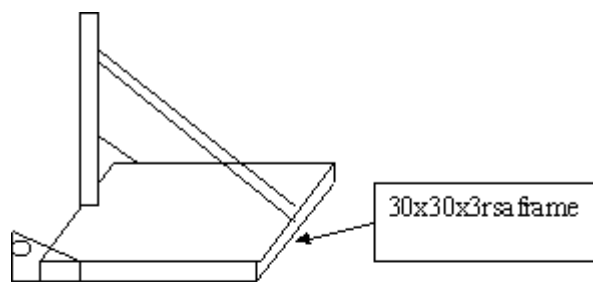

Figure3 Loading Door

5. The chimney spigot. This is made from 30x30x3 rsa with a 5mm sheet of mild steel attached, as in Figure 4 below.

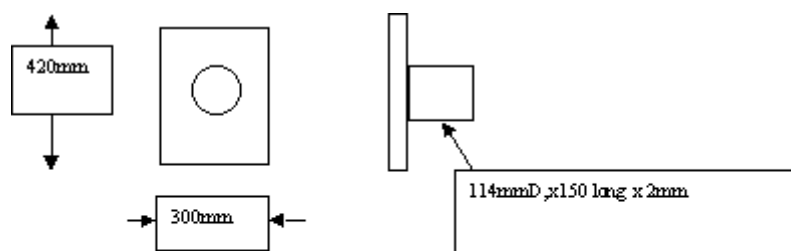

Figure 4 Chimney Spigot

6. The Chimney. The total height of the chimney should be 4 metres. It should have a cross sectional area of 120mm – 150mm, approximately equal to that of the flue. The chimney can be made from a length of steel tube, or from sections of mild steel plate rolled to size and welded together. In either case it is fitted over the chimney spigot and sealed with fire cement. It must then be held upright by 3 cables or a suitable metal frame.

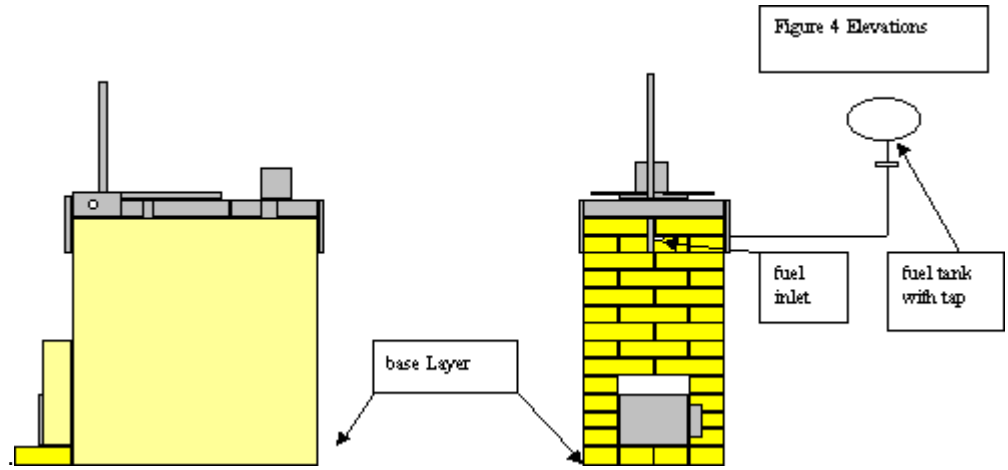
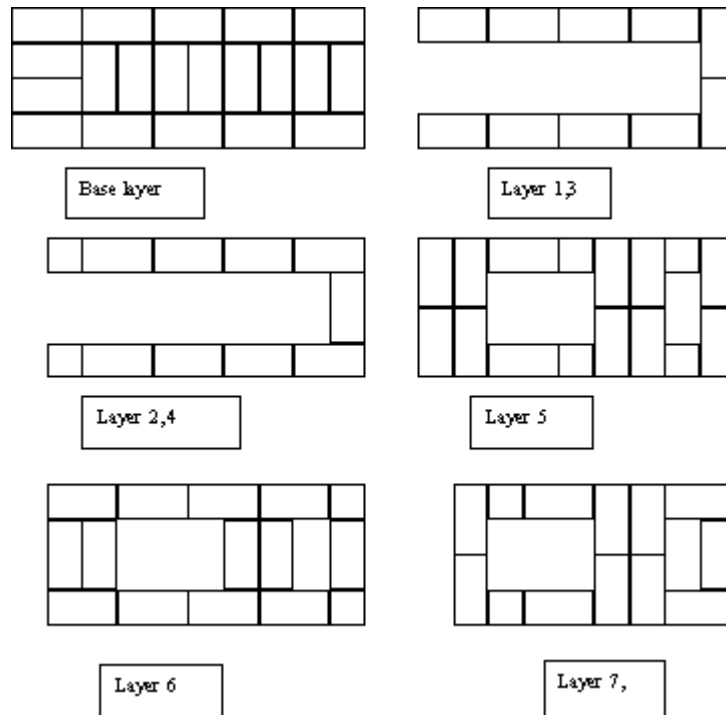
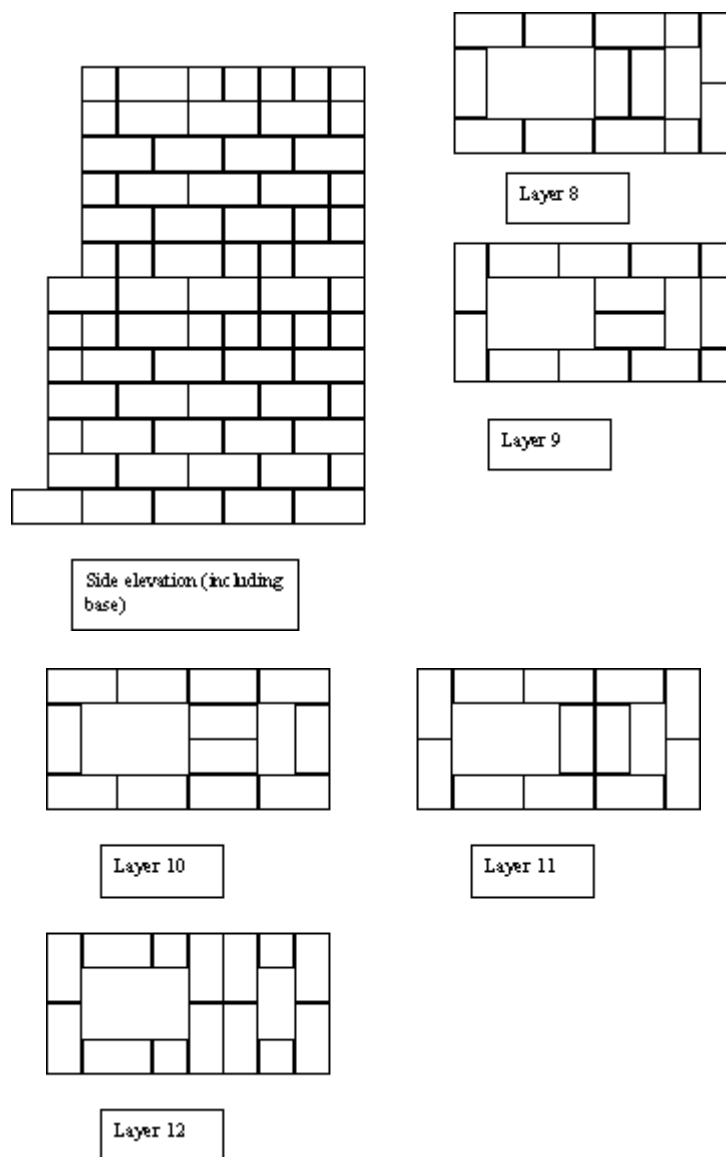
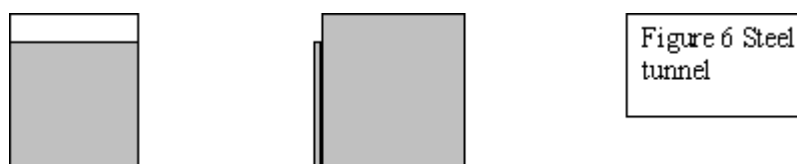

Figure 5 Mark 8a Incinerator brick layers





The brick arch at the front may be supported by a steel tunnel which will also form the frame for the ash door.



6. A grate must be made from 3x3x1/8 in. (30x30x3mm) rsa. This should have an area of 12x8in. (300x200mm) just less than the cross sectional area of the combustion chamber, and should stand 4 inches (100mm) from the base of the combustion chamber. The grate, shown diagrammatically in Figure 7, can be assembled by

welding, riveting or bolting.

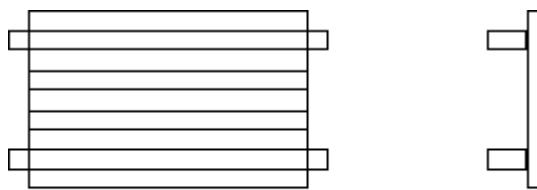

Figure 7. Fire grate

8. Ash Door. This is made from 3mm mild steel plate and covers 75% of the front aperture in the brickwork. Normally this means a height of 10 inches (250mm) and a breadth of 10 inches (250mm), but this may vary if the bricks are of a different size from the standard 9x4.5x3 inch (230x115x76mm) The space above the door allows the air to enter the combustion chamber, and should be approximately 3.5x 9 in.(90x230mm) A hinge is attached to one side of the door and a simple latch to the other. The hinge and latch are attached to the tunnel supporting the brick arch.

Fuel Tank. If it is intended to use liquid fuel, (either kerosene or diesel oil) a fuel tank of at least two litres capacity should be mounted 1 metre above the top of the incinerator, and at least one metre to the side of the incinerator. A fuel tap should be fitted to the tank, and a fuel pipe fitted to take the fuel to a steel pipe of about 5 mm diameter which is passed through the brick or the mortar 100 mm below the top and just protruding into the primary combustion chamber as shown in figure 4.

Materials List

Fire bricks	200 approx, (this will vary with size of available firebricks)
High alumina fire cement	2x25 kg bags
Sand	200 kg
100x40x5 rolled steel channel	4 metres
30x30x3 rolled steel angle	12 metres
3mm flat steel sheet (for loading door)	600mmx750mm (approx)
3mm flat steel sheet (for ash door)	250mmx250mm (approx)
3mm flat steel sheet (chimney spigot support)	250mmx150mm (approx)
120mm (or150mm) chimney, (steel pipe or fabrication)	4 metres
300mm square (approx) tunnel, X 225mm long	3mm flat sheet
Hinges for ash door	
1 inch pipe and ¾ inch rod for loading door hinge	
Masonry plugs (Rawlplugs),	

screws etc.	16 off, Number 10,
Fuel tank, tap and pipe (4metres)	1 of each

Note

If required, the incinerator body can be clamped together with steel bars as in the Mark 1 design.

It can also be surrounded by an outer case of common bricks to give extra strength and weather protection as shown below.

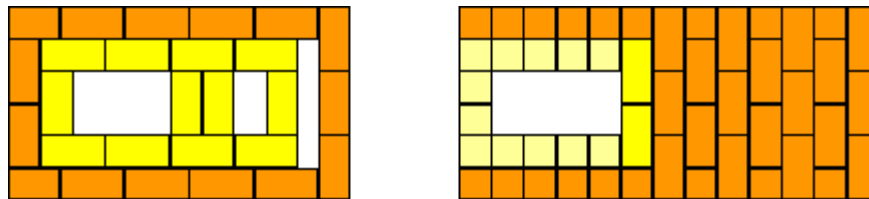

The top of the bricks can be sealed with coping tiles or with Portland cement

Operation

The incinerator should be started by putting some waste paper, cardboard or similar easily ignited material over the grate. Burning paper can then be dropped on top, and when a good flame is established, more combustible material added till the combustion chamber is half full. If available, about 100 cc of kerosene or diesel oil or used lubricating oil can be poured on top to speed the heating process, Only dry, non-infected waste should be added for the first 30 minutes or until a fierce flame is established.

The combustion chamber should be kept at least half full, and infectious and/or wet waste should be added above dry materials to ensure that it dries before reaching the combustion zone, Additional liquid fuel can be added if it is suspected that the combustion rate is decreasing. Any plastic waste available will also help to raise the temperature of combustion, but both this and the oil will give rise to black smoke if used to excess.

The incinerator will be most efficient in fuel consumption if it is operated for fairly long periods once it is ignited, but the grate and the flue passage to the base of the chimney must be kept clear by poking a steel rod through the air inlet hole from time to time. It may also be necessary to push down the load from time to time to prevent it "arching" above the grate. The last load before closing down should be as dry and safe as possible, so that no unburned material is left on the grate.

All enquiries should be referred to Professor DJ Picken, De Montfort University, Leicester, UK (email: djpicken@iee.org.uk)

DISCLAIMER

Since the safe and successful use of the incinerator, which operates at very high temperatures, is entirely dependent on the building, operation and maintenance thereof, the University and the organisations supplying the drawings and instructions can bear no responsibility for any mishaps to personnel or inadequate technical performance of the incinerator'.

[go back up](#)

De Montfort University Incinerator

Building the Incinerator Mark IX

This incinerator is a development of the Mark 3 and is to be built where high rates of combustion are required. It simplifies the construction, particularly of the steelwork, and thereby reduces the likelihood of failure due to distortion of the steel top plate.

It should be built on a concrete platform of at least two metres square, and should preferably have a roof to protect it from rain. The roof may also incorporate the support for the chimney stack.

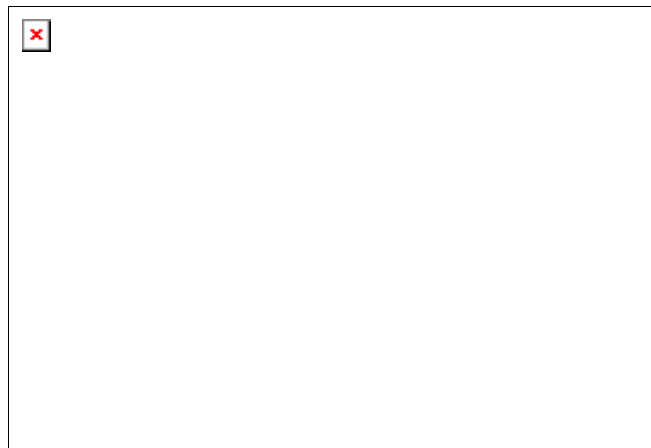

Materials required

Description	Size	Qty
Fire bricks	230x116x76mm	300
Cement (Portland)	25 kg bags	250 kg
Ballast		500 kg
Sand	200 kg (approx)	1000 kg
Fire cement (high alumina)	25 kg	100 kg
Rolled steel angle (mild steel)	40x40x3mm thick	42 metres

Rectangular section mild steel	75x75x3mm wall thickness	2 metres
Flat sheet (mild steel)	2400x1200x3mm	1 sheets
Mild steel pipe	150mm dia x3mm thick (approx)	3 metres
Welding rods (mild steel)		60
Steel cable	5 mm 7 strand	40 metres
Turnbuckles	M8 x150mm long	7
Rolled steel angle (mild steel)	50x50x3mmthick	6 metres
Steel snap rivets (blind rivets)	4.8mmx10mm long	500
Fuel tank with tap.	2 litres capacity approx	1
Fuel pipe, steel	350mm long x 6mm dia	1
Fuel pipe flexible 2 metres x 6mm ID		
Bolts with nuts and washers 10mmx75mmlong 24		
Wire Mesh	Any fine gauge	loose fill

Building the brick body

1. Lay out the base as shown, with approximately 5mm of refractory cement mortar in the gaps. When this is completed, the overall dimensions of the incinerator can be measured so that the steelwork can be started.

Diagram 1 Base layout

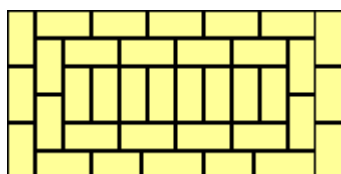

2. Build up the refractory brick body in layers as shown below, taking care to keep all walls vertical. Insert the two mild steel tunnels (3 bricks high x 2 bricks wide) and the air ducts (2 on the primary side, 1 on the secondary side) and fill the gaps with refractory cement and firebrick chips.

.3.

Diagram 2 Layers 1&3



Diagram 3 Layers 2&4

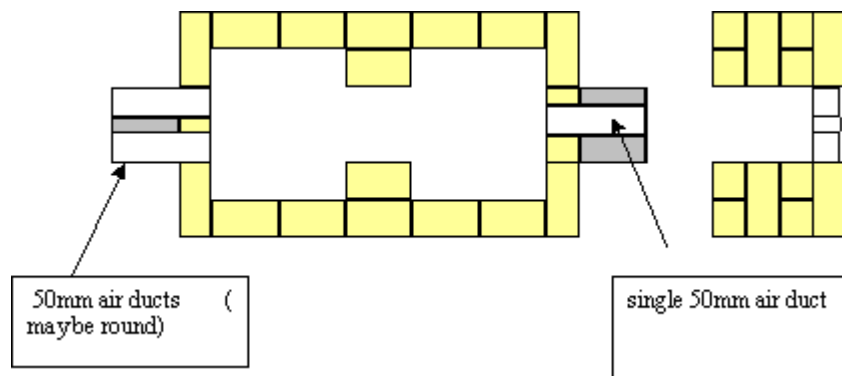

Diagram 4 Layers 5, 7, 9, 11, 13

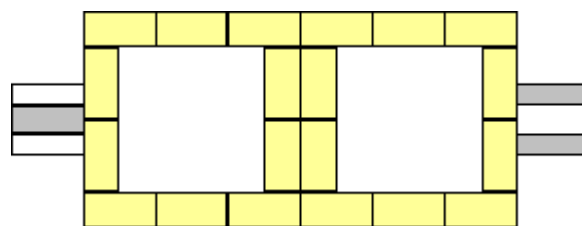
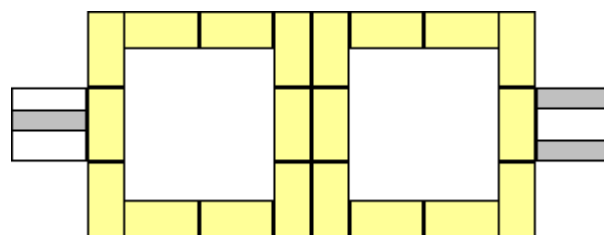
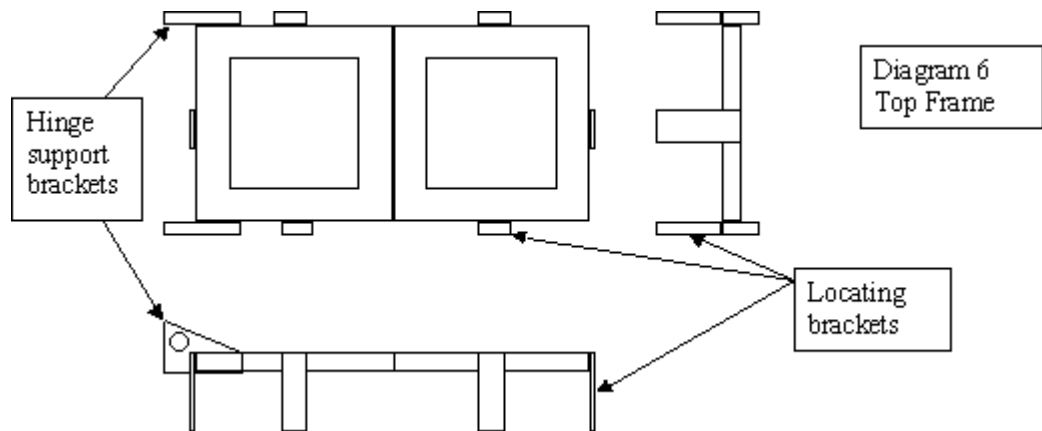

Diagram 5, Layers 6, 8, 10, 12, 14



3. Make and fit the **steel top-frame** as shown below. **-Note** This can be started as soon as the base layer of fire bricks is laid out and measured.



The top frame is made by welding lengths of "U Section" (Channel Section) mild steel to form two joined squares which fit over the brick core. 6 strips of mild steel are welded to the side of the frame as shown to locate the frame on the brick core.

2 plates, shaped as in the diagram, and with 12mm holes in them are also welded to the frame at the primary chamber end to form the pivot for the loading door.

4. **The Loading Door** can now be made with a rolled steel angle frame of size to fit within the square channel top frame

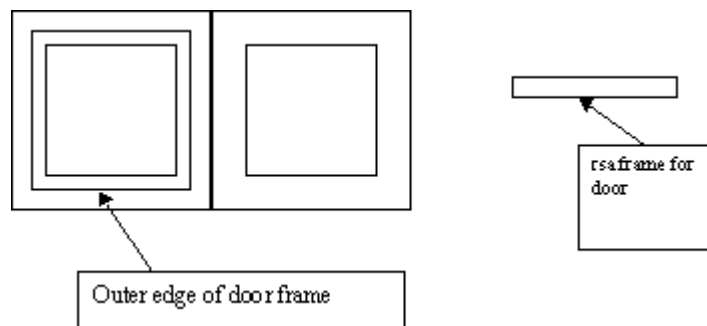

The door may now be completed by adding a mild steel plate to the frame, a pair of hinge brackets and the handle, as shown below.



5 The chimney support panel can be made in a similar manner to the door, but with extra rolled steel angle to support the chimney.

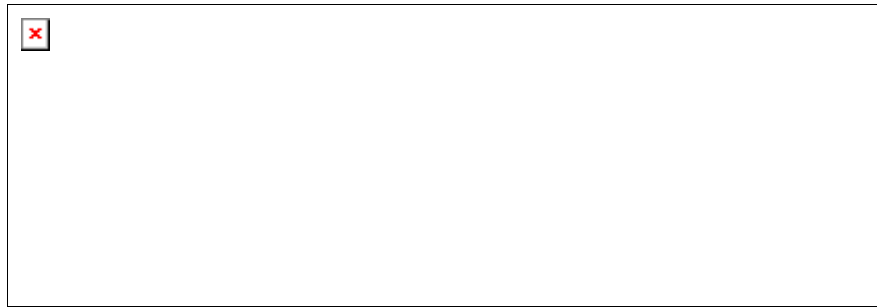

The steel top may now be fitted over the firebrick core and sealed carefully with more refractory cement. This is best achieved by covering the top of the firebricks with a 5mm layer of cement and lowering the steel top on to it, locating the top by means of the brackets already fitted.

6. The outer case can then be built up using common bricks with Portland cement mortar, as shown to a height just less than the inner core. Any space between the two types of bricks may be filled with Portland (white) cement. The top is then sealed with cement.



7. The loading door and chimney support plate with spigot can now be fitted to the steel top. Sealing between both the door and its frame and the chimney support frame is achieved by filling the channels of the frame with soft sand so that the door and support plate rest on the sand.

8. The chimney is either made from a 4 metre length of steel pipe, or fabricated from steel plate. In either case it must be of a diameter to fit easily over the chimney spigot. Two brackets should be welded to the chimney, about 3 metres from the bottom, to attach 4 lengths of steel cable to hold the chimney upright. The other ends of the cables should be firmly fixed to pegs driven or concreted into the ground about two metres from the chimney.

9. A simple **grate** should be made to fit below the primary combustion chamber. It is

constructed of 40x40x3 rsa, with the gaps between the grids not less than 50mm. The legs should be 80mm long. This should be inserted from above through the fire door.

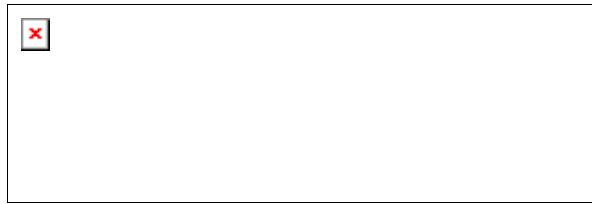

DISCLAIMER

Since the safe and successful use of the incinerator, which operates at very high temperatures, is entirely dependent on the building, operation and maintenance thereof, the University and the organizations supplying the drawings and instructions can bear no responsibility for any mishaps to personnel or inadequate technical performance of the incinerator'.

Any questions relating to these instructions should be referred to

Professor DJ Picken, De Montfort University, Leicester, UK

email djpicken@iee.org.uk

[go back up](#)

[go up / next chapter >>](#)

Medical Waste Incinerator

- * the incinerator
- * various models
- * construction
- * **operating**
- * experiences
- * contact

Operating

For those of you who already have an incinerator model, here you can read about all the necessary step you need to undertake to operate the incinerator.

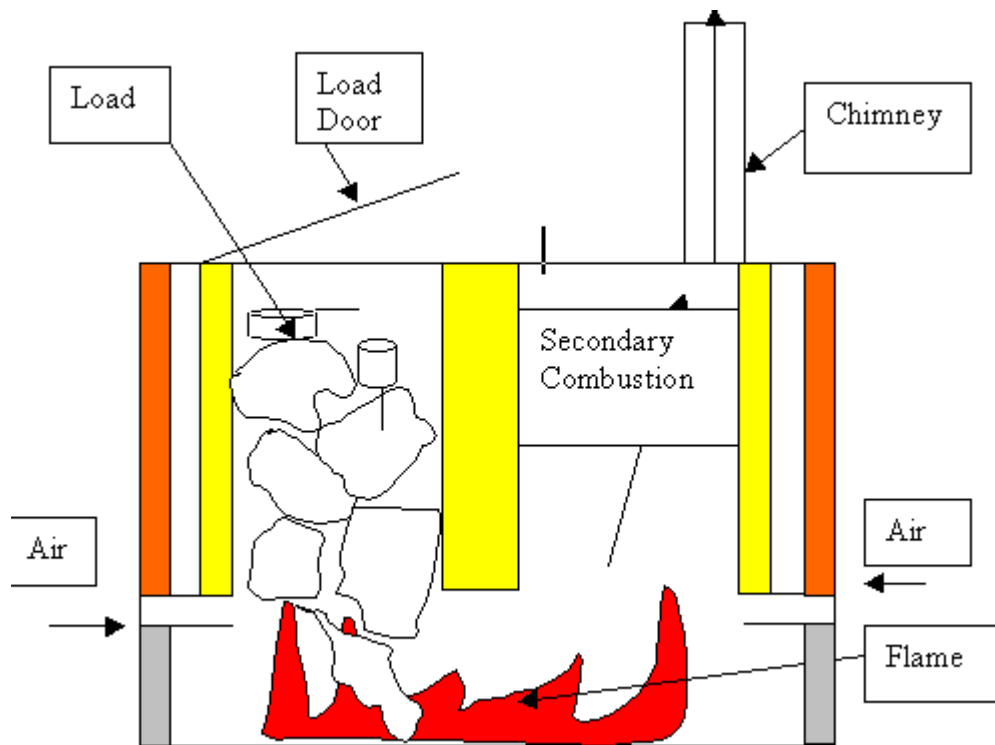

When opening the loading door always wear eye protection and a face mask.

1. Light the incinerator with paper and wood or dry non-toxic waste at the bottom of the primary chamber. The loading door may be kept open for this operation. Add more wood or waste with a small quantity of diesel oil/kerosene till the flame is burning well. Add more dry waste and close the loading door. Light smoke should be observed coming out of the chimney top. Add more fuel at regular intervals till the flame can be seen burning fiercely through the primary air holes. After about half an hour (longer if the incinerator is very cold or wet) the chamber should be hot enough to start loading.
2. Make sure that the chamber is at least 2/3 full of dry matter before adding waste. Before infectious waste is added, flames should be observed through the rear air hole in the secondary chamber. To hurry this process, more diesel/kerosene can be added in the liquid fuel version.
3. Thereafter keep feeding waste in at regular intervals, of between 5 and 10 minutes, keeping the primary chamber as full as possible.
4. If the flame appears to be burning less fiercely, poke out any blockage in the transfer flue between the two chambers. This can be done using a length of steel pushed in through the air holes at the front.

5. Very wet loads should be separated with drier material, and in extreme case supplemented by an extra increment of diesel/kerosene.

6. When the loading door is opened combustible gases may come into contact with air and burn suddenly and fiercely. This is harmless providing the operator is wearing a face mask and is not peering directly into the chamber.

7. When the loading door is closed suddenly more burning gases may come through the air holes. Thus the operator should load from the side.

Safety

Please also read the following safety notes carefully:

Please read the following safety notes carefully. When opening the loading door always wear eye protection and a face mask.

* Opening the loading door on either the wood or kerosene fired version during operation will mean that additional air will enter the combustion chamber. This may cause blow-back to occur and the flame to flare up out of the loading door. The blow-back does not last long but it could cause injury to anyone standing too close to the incinerator.

* Particular care should be taken when using kerosene as atomised vaporised fuel may be present at the top of the combustion chamber which could ignite vigorously.

* The operator should open the door while standing at the front of the incinerator. The loading door is designed so that it hinges from the front of the incinerator and opens towards the operator. This provides the operator with some protection from any blow-back and keeps him/her away from the opening to the combustion chamber.

* The operator should wait a few moments to allow any blow-back to die down before loading waste materials into the incinerator.

Small explosions

Some waste materials such as ampoules and glass bottles containing liquid vaccines and medicines may explode during incineration causing glass and other waste materials to be blown into the atmosphere. The operator should ensure that eye protection and a face mask is worn when opening the loading door or when visually checking the combustion process through the air inlet or when removing the ash door while the incinerator is in use.

Handling waste

- Always wear heavy-duty gloves and apron while handling medical waste. If the waste is bagged hold the bag by the top and away from your body. Drop the bag through the loading door opening and if it gets stuck use a stick to push the bag into the combustion chamber (see Figure 13).

- If the waste is loose, use a shovel to load it into the combustion chamber.

Removing ash and other solids from the combustion chamber

* Never handle the ash or other waste materials by hand. Use a stick or scraper to pull the solids out through the ash door and into a dustpan or box.

* Do not remove the ash or other waste materials from the combustion chamber until they have cooled down. This will take about five hours. If the incinerator is in operation on a daily basis then the ashes and other waste material can be removed the following day as part of the preparation for operation.

* Dispose of the ash and other waste materials carefully by burying or placing in a skip for disposal by local authority or other authorised disposal company.

General operating notes

The following notes are intended to give the operator a basic understanding of how to operate the incinerator. Optimum operation of this incinerator requires frequent attention to ensure that it performs effectively. It will take time for the operator to become familiar with the operation.

Figure 13 - Placing waste into the incinerator. Note that the operator is using a stick to push the waste down and is wearing gloves and eye protection

Waste management

Materials with high fuel values such as plastics, paper, card and dry textile will help maintain high incineration temperature. If possible a good mix of waste materials should be added with each batch. This can best be achieved by having the various types of waste material loaded into separate bags at source i.e. the wards and laboratories, and clearly labelled. It is not recommended that the operator sorts and then mixes the waste prior to incineration as this is potentially hazardous.

The operator can then judge when to place which type of waste into the incinerator at any particular time. If possible some plastic materials should be added with each batch of waste as this burns at high temperatures. However, care and judgement will be needed as too much plastic will create dense dark smoke. Wet kitchen waste should not be placed in the incinerator.

Operating temperatures

The incinerator does not have a temperature gauge and so adequate operating temperatures have to be judged by the operator based on experience. A visual guide is to look through the air inlet and at the colour of the smoke from the stack. If a good strong flame can be seen then the temperature should be more than 800°C at this point and so will be adequate for good incineration. If the smoke is dark grey or black then poor combustion is occurring and the temperature will be below that required.

Starting and Operating the Wood Fuelled Version

- Open the loading door and ash door and remove any ash or other materials from the fire box ensuring that the grate is clean and the entrance to the flue is not blocked.
- Before lighting the incinerator, prepare the fire wood, ensuring that it is dry and chopped or cut into short lengths (that fit horizontally through the loading door) and not more than 75mm (3") in section. If the wood has a high moisture content (i.e. above 15%) then it will be difficult to get the incinerator up to the operating temperature.
- Place paper on the grate and cover with dry kindling and small pieces of wood and/or dry textiles.
- Light the paper through the ash door and NOT through the loading door. (This prevents the operator being burnt if paper and kindling material flare up unexpectedly).
- Once the fire is established and burning well, start adding the fire wood in small amounts.
- The loading door can be closed after about 5 minutes from lighting and once the fire is being drawn from the primary combustion chamber into the secondary chamber and up the stack.
- ash door can be closed once the fire is well established. A well established fire will roar and will be audible through the air inlet tubes. Practice will enable the operator to judge when the fire is established.

- Fire wood and/or dry waste is added at intervals until the incinerator is operating at the right temperature. The operating temperature will be achieved between half and one hour from lighting, depending on the ambient temperature, moisture content of the wood and the type of wood being used (i.e. hard, soft etc.)
- Once up to operating temperature, start to add the general waste material on small batches at regular intervals. The level of material in the incinerator should be such that the incinerator is always above half full.
- If the waste is predominately unwanted drugs, straw or wood may be placed in the incinerator before the drugs to hold the boxes in position for a longer period in order to prevent pills falling through the incinerator without burning. Sharps, including hypodermics, should be mixed with other waste to prevent them falling through the incinerator without being destroyed.
- If the waste material has a high moisture content or has a low fuel value, wood can be added to help maintain the correct operating temperature.
- The grate and flue entry should be checked every 15 minutes and raked clear of any obstruction. This is to ensure that the airways are kept clear. - At the end of the operating session and all the waste has been placed in the incinerator, add more wood to ensure that any waste residue has been completely burned.

Starting and Operating the Kerosene Fuelled Version

Open the loading door and ash door and remove any ash or other materials from the fire box ensuring that the grate is clean and the entrance to the flue is not blocked.

- Place paper on the grate and cover with dry kindling and small pieces of wood and/or dry textiles.
 - Light the paper through the ash door and NOT through the loading door. (This prevents the operator being burnt if paper and kindling material flare up unexpectedly).
 - Once the fire is established and burning well, start adding more card, paper and/or dry waste and kerosene until the incinerator is up to the operating temperature. This will probably take about 112 an hour.
 - The loading door can be closed after about 5 minutes from lighting and once the fire is being drawn from the primary combustion chamber into the secondary chamber and up the stack-
 - The ash door can be closed once the fire is well established. A well established fire will roar and will be audible through the air inlet tubes. Practice will enable the operator to judge when the fire is established.
 - Once up to operating temperature, start to add the general waste material in small batches at regular intervals. The level of material in the incinerator should be such that the incinerator is as above half full.
- If the waste is predominately unwanted drugs, straw may be placed in the incinerator before the drugs to hold the boxes in position for a longer period in order to prevent pills falling through the incinerator without burning, Sharps, including hypodermics, should be mixed with other waste to prevent them falling through the incinerator without being destroyed. If the waste material has a high moisture content or has a low fuel value, kerosene can be added to help maintain the correct operating temperature. The grate and flue entry should be checked every 15 minutes and raked clear of any obstruction. This is to ensure that the airways are kept clear. At the end of the operating session and all the waste has been placed in the incinerator, add more paper, card and kerosene to ensure that any waste residue has been completely burned.

Note: If the incinerator is in an enclosed space, place kerosene/diesel soaked paper/rag directly under the flue and dry material in the combustion chamber. Then, with the loading door closed light the incinerator from beneath the grate. This prevents fumes entering the enclosure.

go up / next chapter >>