

Mud pump set is mounted on a steel skid, powered by a petrol/diesel engine, and mechanically driven by 2 V-belts.

The pump is 2-stages centrifugal, self-priming, 2 ball valves and hand primer pump, completed with a hoses set.

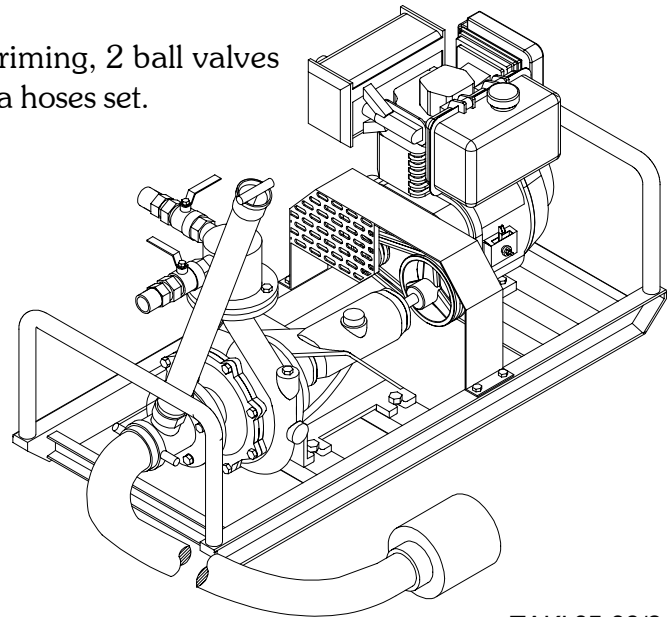
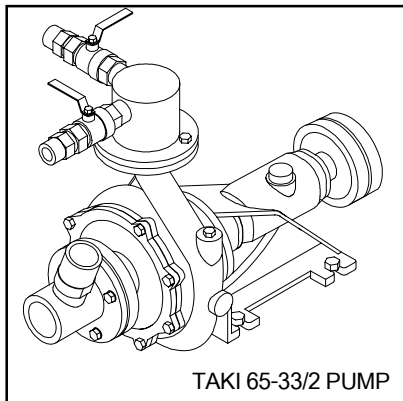

Technical Specifications

Engine Type :	10 HP YANMAR diesel engine (Optional 13 HP HONDA petrol) hand starting, 3600 rpm, air-cooled
Mud Pump Type :	2-stages centrifugal, TAKI model : 65-33/2 Displacement : 1000 litres/min at 30 metres head 600 litres/min at 50 metres head Max. pressure : 4 bar
Weight :	Skid unit: 156 kg (diesel), 146 kg (petrol)
Water Hoses :	Suction hose 3 inch x 4 m long Pressure hose 1 1/2 inch x 6 m long Drain hose 1 1/2 inch x 4 m long
Shipping Data :	NW : 172 kg (petrol), 182 kg (diesel) GW : 209 kg (petrol), 220 kg (diesel) DIM: 71 x 130 x 75 cm