

PAT-Drill 301/2000

DTH. Hammer and Rotary Drilling Machine

The PAT-Drill 301/2000 is a compact and portable hydraulic drilling rig for Down-the-hole Hammer and Rotary drilling in deposits, sedimentary and rock formations, to average depths of 100 meters.



The PAT-Drill 301/2000 is an upgraded design of the well-known PAT-Drill 301A, resulting from the precious feedbacks by its very numerous users worldwide and from the constant researches of our Engineers.

Lighter, stronger, quicker to set up and equipped with a Swing-a-side Top Head Drive, the PAT-Drill 301/2000 is today, by far, the most efficient portable compact rig among its category all over the world.



More than ever, the new design focus on addressing the challenges while drilling in the most remote areas by integrating the concepts of lightness, modular kit, simple operation and easy maintenance.

The PAT-Drill 301/2000 is the right choice for Government, United Nations, and Non-Governmental (NGO) organizations looking for appropriate and low cost drilling equipment to provide domestic water supplies to rural village communities at an economical price.

Technical Data, Specifications

Drilling capacity

Hard rock

4"-6" diameter to a depth of 100 meters with Down The Hole Hammer.

Alluvial deposits

4"-8" diameter to required depth using fluid flush rotary.

Technical specification

DRILLING UNIT BASIC RIG,

MAST

3 metre high, all steel construction 320 kgs. in weight, 2.20 metre drill head travel, Break-out table to open 200 mm., equipped with 2 wheel tires., The Mast is vertical for drilling and horizontal for travelling, enable to load on/off the truck by manual labour.

CONTROL PANEL

Operating's Control panel equipped with 4 main levers for control drill head travelling, and rotating, feed system equipped 2 controllers, slow/rapid drill head speed and determination of feed system and 3 pressure gauges are one unit to be mounted on the Mast.

ROTATION HEAD

Hydraulic motor drive via 3.875 : 1 ratio epicycle reduction gearbox, both forward/reverse rotating, Speed range : 0-70 rpm., Torque : 136 kg-m. (1320 N-m.)

SWIVEL to be mounted on the rotation, a swivel spindle 40 mm. ID. with packing suitable for air, foam and mud flushing, safety working pressure of 20 bar.

Enable to open swing-a-side to easy the casing installation.

HYDRAULIC POWER PACK

Hydraulic system to be operated from skid mounted engine driven power pack with flexible hydraulic hoses fitted to the rig.

125 kgs in weight.

- Engine : 10 HP 3600 rpm. diesel engine, hand starting, water cooled. (or 13 HP 3600 rpm petrol engine)
- Hydraulic system : VANE PUMP type, system pressure 210 bar, 40 litre Tank capacity,
- Hydraulic hose line : 2 lengths, 4 metre long with quick couplings to rig.
- Weight : 171 kg. (diesel engine)
153 kg. (petrol engine)

RIG ACCESSORIES

Set of accessories for Rig installation and drilling operation comprising of : Rig supporters, Break-out table, Drill pipe keys, Ground anchorages, Hand auger, Rig casing clamps and Drill pipes rack.

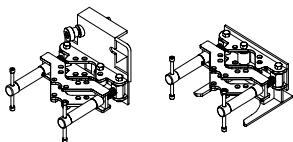

2-Rig casing clamps

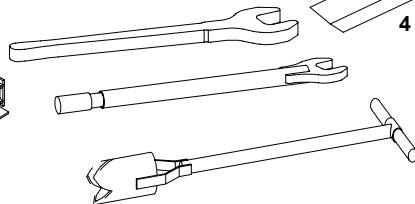

4 -Levelling adjusters

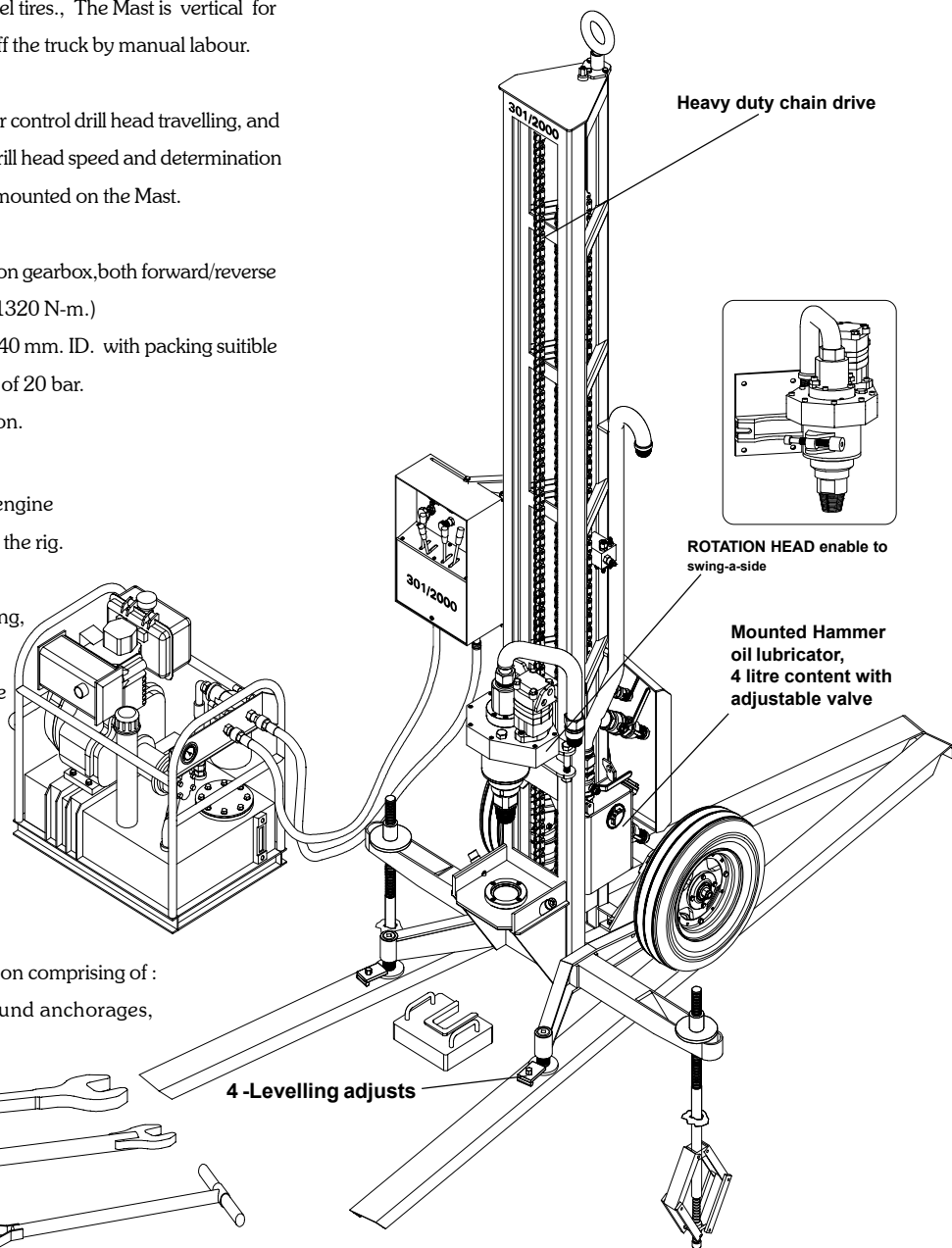

Heavy duty chain drive

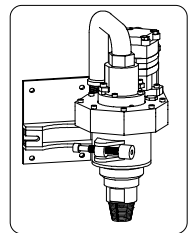

ROTATION HEAD enable to swing-a-side

Mounted Hammer oil lubricator, 4 litre content with adjustable valve

Drilling Rigs, Equipment, Supplies & Accessories

PAT

www.pat-drill.com

PROMOTION OF APPROPRIATE TECHNOLOGY CO.,LTD.

44/5 SOI ATIT, WUTAKARD ROAD, CHOMTHONG, BANGKOK 10150 THAILAND
Phone (66-2) 4761845, 4765313 FAX (66-2) 4765316 Email: pat@pat-drill.com

Authorized distributor in East Africa

PAT AFRICA DRILLING LTD.

P.O. BOX 39638 NAIROBI, KENYA Phone / FAX (254-2) 49084 / 49087 Email: nairobi@pat-drill.com