

# PAT-Drill 301T

## Compact, Portable Trailer Mounted Drilling Rig

PAT-Drill 301T is a compact trailer mounted hydraulic drilling rig, designed for both inclined and vertical drilling.

Combining Maneuverability, low consumption, Rotary and Down-the-hole drilling, the PAT-Drill 301T is ideal off-road multipurpose rig for both water drilling and construction works.



- Drill depth 0 - 100 meter.
- 4" - 8" Borehole diameter.
- Mud Rotary drilling and Down The Hole Hammer.
- The ability to drill at different angles, 0 - 30°
- Multipurpose, Water Well and Construction applications.
- Faster drilling rates.

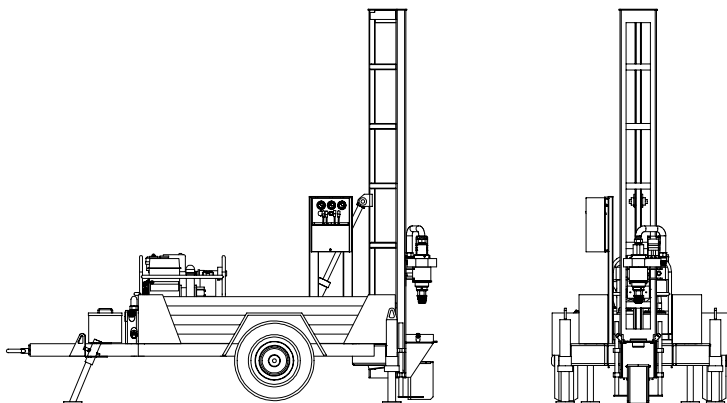

*The PAT-Drill 301T is the right choice for Construction works and minings, looking for appropriate and low cost drilling equipment to find out drilling solutions and challengeable jobs.*

## Technical Data, Specifications

### RECOMMENDED HOLE RANGE

Hard rock formation  
3" - 4" DTH Hammer 90 - 150 mm. 3 1/2" - 6"

Flushing by Air compressor.  
250 - 400 cfm. Displacement  
7 - 16 bar Working pressure

Alluvial deposits, Sedimentary by Mud Rotary.

Drag bit 100 mm. - 200 mm. (4" - 8")

### HOLE DEPTH

Drill depth upto 100 meter

### ROTATION HEAD

Single reduction gearbox with a hydraulic moter.  
The system provides infinity variable rotation speed.  
Enable to Swing-a-side.

Main shaft of 40 mm. hole, Sub joint 2 3/8 API REG Mod

Gear box ratio 3.875 : 1  
Rotation torque 185.67 kg.m.  
Speed 0 - 70 rpm.

### MAST

All steel construction, 3 M. hight, Break-out table to open 200 mm. The Mast is vertical and angular positions by hydraulic cylinder, from 0 - 30°

### FEED SYSTEM

Rotation head drive by hydraulic cylinder through heavy duty chain.

Head travel	2.25 meter
Pull up	
Capacity	2063.07 kg.
Speed (max)	12.83 m/min
Pull down	
Capacity	2063.07 kg.
Speed (max)	9.33 m/min
Feed	
Speed (max)	5.08 m/min

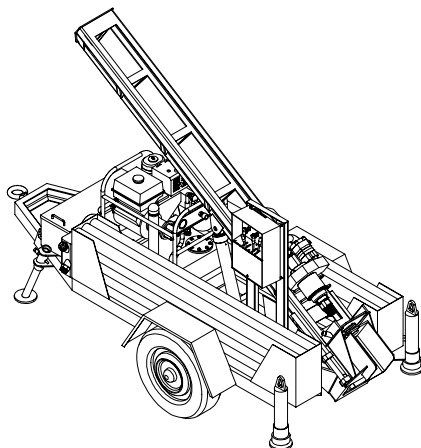

### CONTROL PANEL

- 6 main levers controlling, feeder and jacks.
- 1 speed adjuster
- 1 feed adjuster
- 3 pressure gauges

### HYDRAULIC POWER PACK

Hydraulic system to be operated from skid mounted engine driven power pack with flexible hydraulic hoses fitted to the rig. 125 kg. in weight.

- Engine : 13 hp 3600 rpm. HONDA gasoline engine, air-cooled, hand starting (10 hp YANMAR diesel engine is available.)
- Hydraulic system : VANE PUMP type, system pressure 210 bar, 40 litre Tank capacity

### STABILIZING JACK

- 2 front jacks and 2 rear jacks.
- 2 - Rear jacks Hydraulic jack
- 2 - Front jacks Manually jockey jack

### AIR SYSTEM

Fitted Lubricator of venturi-type for down-the- hole drills.

Max. pressure 20 bar  
Oil tank capacity 4 liters

### PIPES RACK

Capacity 30 pcs. Drill pipe

### DRILL PIPE

Drill pipe length 2.00 meter  
Drill pipe diameter 76 mm. OD, 69 mm. ID  
Thread 2 3/8 API REG Mod, PIN and Box

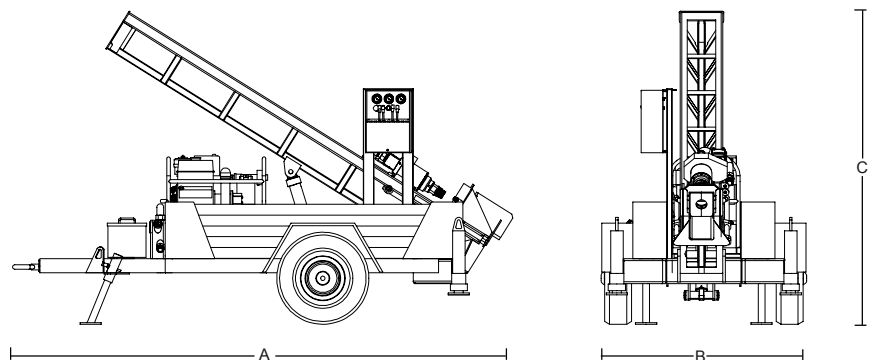

### DIMENSIONS

Overall length (A) : 3530 mm.  
Overall width (B) : 1440 mm.  
Overall height (C) : 3212 mm.