

ACF : Action Contre La Faim

ACF/PAT

Drilling machines and accessories.

model:

ACF/PAT 201

ACF/PAT 301

ACF/PAT 401

August 1999

Price validity: December 31, 1999

PAT : Promotion of Appropriate Technology Co.,Ltd.

In 1998, ACF and PAT cooperated to improve PAT Drilling machines, Accessories and packed arrangements. We called the improved machines as “ACF/PAT”, there were 3 models; ACF/PAT 201, ACF/PAT 301 and ACF/PAT 401.

The main improvements as:

ACF/PAT 201

- To improve the mast; added pulley for advantage when pull up.
- To improve the drill pipe; bigger size.
- To change the mud pump to be more pressure.
- To change the borehole development compressor to be more displacement.
- To change the air hose on reel stand; longer (from 50 to 80 metre)
- To improve the tools set; more kinds, quantity and quality.
- To change the painting color; white paint

ACF/PAT 301

- To improve the hydraulic system.
- To improve the mud pump.
- To improve the borehole development compressor.
- To improve the tools set.
- To change the painting color; white paint.

The ACF/PAT 401, the first machine had supplied to ACF in September 1998, now it is working in Honduras.

In 1999, PAT also re-improved for the ACF/PAT models as adding Rig casing clamp for the model 301 and 401, changing the mud pump for the 401 to be a 2 stages centrifugal pump and improving in some parts of hydraulic system to be more efficiency.

PAT are pleased to confirm the quoted prices of 1998 are still validated to the end of 1999. Please find details of prices, packing, drawings of each models in this book. For more information, please contact us as the following address:

Promotion of Appropriate Technology co.,ltd.
44/5 Soi Atit, Wutakard road, Chomthong
Bangkok 10150 THAILAND

Phone (66-2) 4761845, 4765313
Fax (66-2) 4765316
Email pat-drill@a-net.net.th

GENERAL SPECIFICATIONS**1. 201-BASIC RIG 20 1 1000-AP*****Price \$ 2,460.00***

- 201 Mast, equipped with 5 pulleys, 11.50 metre cable for pull up, Ratio 4:1
- Top head drive, driven by 5 hp. Honda GXV-140 petrol engine.
- Rig accessories; 2-Anchorage, 1-Auger, 2-Rig supporter frames.

2. MUD PUMP 30 3 1000-AP***Price \$ 2,080.00***

- TAKI pump model: 65-26 driven by 13 hp Honda GX-390 petrol engine.
Capacity: 240 gpm. 40 m. Head.
- Hoses set; 3 inch x 4 m. long for Suction, 1 ½ inch x 6 and 4 m. long for Injection and Drain.
All of fitting thread type with O ring seal.

3. BOREHOLE DEVELOPMENT COMPRESSOR 30 4 0888/1302-AP***Price \$ 2,240.00***

- FUSHENG Compressor model TA-80, 3 Cylinder Triplex piston compressor driven by 13 hp Honda GX-390 petrol engine.
Capacity : 27.1 cfm. Pressure 10 Bar max.
- Air hose contained on Reel Stand, total long 80 metre.

4. DRILL PIPES 20 5 1000-AP***Price \$ 1,280.00***

- Drill pipe, 50 mm. OD, 1.5 m. long, Taper thread type (201A) with Cap protector.
- Total of 40 unit, 60 metre depth

5. BITS AND SUB ADAPTORS***Price \$ 1,212.32***

- 1 pc. Drag Bit 8 inch (200 mm) 3 wing step type
- 2 pcs. Drag Bit 6 ½ inch (165 mm) 3 wings step type
- 2 pcs. Drag Bit 4 inch (100 mm) 3 wings step type
- 2 pcs. Drag Bit for Clay 6 ½ inch (165 mm) 2 wings flat type, special designed
- 2 pcs. Sub adaptor 201A female x 2 3/8 API REG female
- 1 pc. Sub adaptor 201A female x 3 1/2 API REG female
- 1 pc. Sub adaptor 201A female x 201 male (for adapt the old model Drag bit)
- 1 pc. Sub adaptor 201 female x 201A male (for adapt the old model Drill pipe)
- 1 set Carbide grinding set

ACF/PAT 201

6. TOOLS

ACF/PAT TOOLS

Price \$ 1,718.60

- 1 pc. Pipe wrench (red) 24 inch long handle "RIDGID" brand
- 1 pc. Pipe wrench (red) 36 inch long handle "RIDGID" brand
- 1 pc. Pipe wrench (green) 4 inch jaw "Sandvik" brand
- 2 pcs. Chain tong for 6 inch pipe
- 1 pc. Casing clamp for 175-200 mm Casing diameter
- 1 pc. Casing clamp for 100-125 mm Casing diameter
- 1 pc. Male Fishing tool
- 4 pcs. Soil collecting boxes
- 1 set Air hose locker with Tee
- 5 pcs. PAT Crew cap (with ACF logo)

1 package *Operating Tools box for 1 machine, comprising of*

- 1 pc. Metal Tools box
- 2 pcs. 10 inch Lock Pincer (VISE GRIP)
- 1 pc. 10 inch Adjustable pliers
- 1 pc. Grease gun
- 1 pc. Steel saw including 5 pcs Spares
- 1 set Double ended spanner (6-22 mm)
- 1 set Ended and Ring spanner (10-19 mm)
- 1 pc. 7 inch Snap ring pliers
- 1 pcs. 3 lb. Metal Hammer
- 4 pcs. Screw driver (Cross and Flat)
- 2 pcs. Folding rule 3 Meter
- 1 set Reversible ratchet and necessary Socket
- 1 set Allen wrench (L-Key) 3-8 mm
- 2 pcs. Measurement level with magnetic
- 1 pc. Oil can
- 1 pc. Steel brush
- 1 pc. Spark plug socket

7. LUBRICANTS

Price \$ 180.00

- 2 x 5 litre SAE 40 motor oil
- 1 x 5 litre SAE 140 Gear oil
- 3 x 1 kg. Lithium Grease
- 3 x 1 kg. Copper Grease

8. SPARE PARTS

Price \$ 992.20

- 1 pack 201 Rig service pack
- 1 pack 201 Top Head Drive service pack
- 1 pack TAKI Mud pump service pack
- 1 pack 5 hp Honda GXV-140 service pack
- 2 pack 13 hp Honda GX-390 service pack

ACF/PAT 201 Total price is \$ 12,163.12
--

August 1999

ACF/PAT 301

GENERAL SPECIFICATIONS

1. 301 BASIC RIG 30 1 1000-AP *Price \$ 15,400.00*

- 301 Basic Rig, equipped with Control panel, Rotation head, Rig wheel
 - Rotation head Hydraulic motor drive via 3.874 : 1 ratio, Speed 0-40 rpm.
 - Hydraulic Power pack driven by 13 hp Honda petrol engine, VAN Pump type for system
 - Pressure 210 bar, 40 litre Tank capacity.
- Hydraulic system: 3 circuit for separate operation of Rotation, Pull and Feed
- Rig accessories; 2-Anchores, 1-Auger, 2-Rig supporter frame, 1-Breakout table, 2-Drill pipe key, 1-Drill pipes rack, Rig casing clamp (new designed)
 - Frame kit for mounted the Rig on Toyota Land cruiser.

2. MUD PUMP 30 3 1000-AP *Price \$ 2,080.00*

- TAKI pump model: 65-26 driven by 13 hp Honda GX-390 petrol engine.
Capacity: 240 gpm. 40 m. Head.
- Hoses set; 3 inch x 4 m. long for Suction, 1 ½ inch x 6 and 4 m. long for Injection and Drain.
All of fitting thread type with O ring seal.

3. BOREHOLE DEVELOPMENT COMPRESSOR 30 4 0888/1302-AP *Price \$ 2,240.00*

- FUSHENG Compressor model TA-80, 3 Cylinder Triplex piston compressor driven by 13 hp Honda GX-390 petrol engine.
Capacity : 27.1 cfm. Pressure 10 Bar max.
- Air hose contained on Reel Stand, total long 80 metre.

4. FOAM INJECTION PUMP 30 7 3000-AP *Price \$ 860.00*

- 3 Cylinder, Triplex piston pump driven by 3.8 hp Honda GX-120 petrol engine.
Capacity : 5 gpm., 35 bar pressure max.
- Hoses set; 25 mm. x 2 m. long for Suction, 6 mm x 20 m. long for Injection complete with adjustable flow jet gun.

5. DRILL PIPES 30-5-1000-AP *Price \$ 4,400.00*

- Drill pipe, 76 mm. OD, 2.0 m. long, 2 3/8 Mod Reg API with Cap protector.
- Total of 50 unit, 100 metre depth *

6. BITS AND SUB ADAPTORS *Price \$ 1,820.32*

- 2 pcs. Drag Bit 9 inch (245 mm) 3 wing step type
- 1 pc. Drag Bit 8 inch (200 mm) 3 wing step type
- 2 pcs. Drag Bit 6 ½ inch (165 mm) 3 wings step type
- 2 pcs. Drag Bit 4 inch (100 mm) 3 wings step type
- 2 pcs. Drag Bit for Clay 6 ½ inch (165 mm) 2 wings flat type, special designed
- 3 pcs. Sub adaptor 2 3/8 API REG female x 2 3/8 API REG female
- 2 pcs. Sub adaptor 2 3/8 API REG female x 3 1/2 API REG female
- 1 set Carbide grinding set for Honda engine

ACF/PAT 301

7. AIR FLUSHING ACCESSORIES

Price \$ 734.00

- 1 set Air hoses set with coupling, 10 and 5 m. long
- 1 pc. Oil lubricator
- 1 pc. Starter Drill pipe
- 1 pc. Nipple 1 ½ x 1 ½ inch for Atlas Copco Compressor gate valve

8. TOOLS

ACF/PAT TOOLS

Price \$ 1,758.60

- 1 pcs. Pipe wrench (red) 24 inch long handle "RIDGID" brand
 - 1 pc. Pipe wrench (red) 36 inch long handle "RIDGID" brand
 - 1 pc. Pipe wrench (green) 4 inch jaw "Sandvik" brand
 - 2 pcs. Chain tong for 6 inch pipe
 - 1 pc. Casing clamp for 175-200 mm Casing diameter
 - 1 pc. Casing clamp for 100-125 mm Casing diameter
 - 1 pc. Male Fishing tool *
 - 4 pcs. Soil collecting boxes
 - 1 set Air hose locker with Tee
 - 5 pcs. PAT Crew cap (with ACF logo)
 - 5 pcs. Safety cap
- 1 package Operating Tools box for 1 machine, comprising of*
- 1 pc. Metal Tools box
 - 2 pcs. 10 inch Lock Pincer (VISE GRIP)
 - 1 pc. 10 inch Adjustable pliers
 - 1 pc. Grease gun
 - 1 pc. Steel saw including 5 pcs Spares
 - 1 set Double ended spanner (6-22 mm)
 - 1 set Ended and Ring spanner (10-19 mm)
 - 1 pc. 7 inch Snap ring pliers
 - 1 pcs. 3 lb. Metal Hammer
 - 4 pcs. Screw driver (Cross and Flat)
 - 2 pcs. Folding rule 3 Meter
 - 1 set Reversible ratchet and necessary Socket
 - 1 set Allen wrench (L-Key) 3-8 mm
 - 2 pcs. Measurement level with magnetic
 - 1 pc. Oil can
 - 1 pc. Steel brush
 - 1 pc. Spark plug socket
 - 1 pc. Filter chain wrench

9. LUBRICANTS

Price \$ 560.00

- 1 x 18 litre SAE 40 motor oil
- 1 x 18 litre Hydraulic oil
- 5 x 1 kg. Lithium Grease
- 5 x 1 kg. Copper Grease
- 2 x 20 litre Rock Drill oil
- 1 x 25 litre Liquid Drilling Foam

10. SPARE PARTS

Price \$ 1,694.00

- 1 pack 301 Rig service pack
- 1 pack 301 Rotation service pack
- 1 pack 301 Power pack service pack
- 1 pack TAKI Mud pump service pack
- 1 pack Foam pump service pack
- 3 pack 13 hp Honda GX-390 service pack
- 1 pack 3.8 hp Honda GX-120 service pack

ACF/PAT 301 Total price is \$ 31,546.92

August 1999

WATER WELL DRILLING MACHINE: ACF/PAT 401

3-May-2000

The ACF/PAT 401 is a compact fully hydraulic drilling rig. The basic rig is a Platform to be mounted on TOYOTA Land Cruiser, 4WD pickup truck, model : HZJ 75P, engine 4164 CC. The Drilling system to be powered by truck engine, Tower Take Off: PTO.

GENERAL SPECIFICATIONS

1. 401 BASIC RIG	40-1-1000-AP	Price \$ 31,500.00
<ul style="list-style-type: none">- Complete unit Platform equipped all equipment, Mast, Hydraulic and Power pack system, Brake signal lighting, eye hook for trailer. The Mast is vertical for drilling and horizontal for Travelling.- Powerful by Power Take Off (PTO) driven all hydraulic system, Mud pump, Foam pump.- Rotation head Hydraulic motor drive via. 4.75 : 1 ratio, Speed 0-40 rpm with Speed adjustable.- 125 litre, Hydraulic tank capacity.- Hydraulic oil Cooling.- Hydraulic Breakout wrench for disconnecting Drill pipe.- Mobile Mud pump driven by Hydraulic system, NEW IMPROVED TAKI pump model : 65-33/2, Centrifugal 2 stages pump. (new improved) Capacity (litre/min) : 1000 at 30 m and 600 at 50 m., complete with Hoses.- Foam pump driven by Hydraulic system, 3 Cylinder, Triplex piston pump, Capacity : 5 gpm., 35 bar max complete with Hoses.- 4 Hydraulic Leveling Jacks.- 12 Volt Electric system with Night lights.- Drill pipe rack- Tools Boxes- Rig accessories : 2-Drill pipe keys, 1-Breakout Table, 1-Centralizer, Dusty cover set, Jack footers set, Rig casing clamp (new designed).		
INSTALLATION ON TRUCK AND TRAINING		Price \$ 3,000.00
<p>To be complete rig and the most efficiency, PAT offer our engineers who will install the Rig on truck at site work and train the users to operate all system. This cost is also including the oversea tickets for our engineers.</p> <p>*** THIS PRICE IS NOT INCLUDING A TOYOTA LAND CRUISER TRUCK. ***</p> <p><i>Remark: The trailer option will be added 1200 USD. See attached drawing</i></p>		
2. BOREHOLE DEVELOPMENT COMPRESSOR	30 4 0888/1302-AP	2,484.00
<ul style="list-style-type: none">- FUSHENG Compressor model TA-80, 3 Cylinder Triplex piston compressor driven by 13 hp Honda GX-390 petrol engine. Capacity : 27.1 cfm. Pressure 10 Bar max.- Air hose contained on Reel Stand, total long 80 metre. <p><i>Remark: the diesel engine option wil be 3,368 USD "YANMAR L-100, 10 hp air-cooled, hand starting.</i></p>		
3. DRILL PIPES	30-5-1000-AP	Price \$ 4,620.00
<ul style="list-style-type: none">- Drill pipe, 76 mm. OD, 2.0 m. long, 2 3/8 Mod Reg API with Cap protector.- Total of 50 unit, 100 metre depth		

4. BITS AND SUB ADAPTORS**Price \$ 1,820.32**

- 2 pcs. Drag Bit 9 inch (245 mm) 3 wing step type
- 1 pc. Drag Bit 8 inch (200 mm) 3 wing step type
- 2 pcs. Drag Bit 6 ½ inch (165 mm) 3 wings step type
- 2 pcs. Drag Bit 4 inch (100 mm) 3 wings step type
- 2 pcs. Drag Bit for Clay 6 ½ inch (165 mm) 2 wings flat type, special designed
- 3 pcs. Sub adaptor 2 3/8 API REG female x 2 3/8 API REG female
- 2 pcs. Sub adaptor 2 3/8 API REG female x 3 1/2 API REG female

5. AIR FLUSHING ACCESSORIES**Price \$ 578.00**

- 1 set Air hoses set with coupling, 15 m. long
- 1 pc. Starter Drill pipe
- 1 pc. Nipple 1 ½ x 1 ½ inch for Atlas Copco Compressor gate valve

6. TOOLS**Price \$ 1,758.60**

- 1 pc. Pipe wrench (red) 24 inch long handle "RIDGID" brand
- 1 pc. Pipe wrench (red) 36 inch long handle "RIDGID" brand
- 1 pc. Pipe wrench (green) 4 inch jaw "Sandvik" brand
- 2 pcs. Chain tong for 6 inch pipe
- 1 pc. Casing clamp for 175-200 mm Casing diameter
- 1 pc. Casing clamp for 100-125 mm Casing diameter
- 1 pc. Male fishing tool
- 5 pcs. Soil collecting boxes
- 2 pcs. 2 inch Tee and 1 ½ inch Tee
- 1 pc. Hose locker clamp for developing Air hose.
- 5 pcs. PAT Crew cap (with ACF logo)
- 5 pcs. Safety cap
- 1 package **Operating Tools box** for 1 machine, comprising of
 - 1 pc. Metal Tools box
 - 2 pcs. 10 inch Lock Pincer (VISE GRIP)
 - 1 pc. 10 inch Adjustable pliers
 - 1 pc. Grease gun
 - 1 pc. Steel saw including 5 pcs Spares
 - 1 set Double ended spanner (6-22 mm)
 - 1 set Ended and Ring spanner (10-19 mm)
 - 1 pc. 7 inch Snap ring pliers
 - 1 pc. 3 lb. Metal Hammer
 - 4 pcs. Screw driver (Cross and Flat)
 - 2 pcs. Folding rule 3 Meter
 - 1 set Reversible ratchet and necessary Socket
 - 1 set Allen wrench (L-Key) 3-8 mm
 - 2 pcs. Measurement level with magnetic
 - 1 pc. Oil can
 - 1 pc. Steel brush
 - 1 pc. Spark plug socket
 - 1 pc. Filter chain wrench

7. LUBRICANTS	Price \$	560.00
<ul style="list-style-type: none"> - 1 x 18 litre SAE 40 motor oil - 1 x 18 litre Hydraulic oil - 5 x 1 kg. Lithium Grease - 5 x 1 kg. Copper Grease - 2 x 20 litre Rock Drill oil - 1 x 25 litre Liquid Drilling Foam 		

8. SPARE PARTS	Price \$	1,649.00
<ul style="list-style-type: none"> - 1 pack 401 Rig service pack - 1 pack 401 Rotation service pack - 1 pack 401 Power pack service pack - 1 pack TAKI Mud pump service pack - 2 pcs. Impeller for TAKI 65-33/2 pump - 1 pack Foam pump service pack 		

ACF/PAT 401 Total price in US.Dollar	47,969.92
---	------------------

Water Well Drilling Machines properties

Description	ACF/PAT 201	ACF/PAT 301	ACF/PAT 401 LC-PTO
Physical information	alluvial, soil, clay	all kinds	all kinds
Drill depth	0-60 m.	0-80 m., 100 m. is possible.	0-100 m.
Borehole diameter in alluvial Drilling by Direct rotary, mud flushing	3 ½" – 6 ½" or 8" in some area.	4" – 9" or more in some areas.	4" – 9" or more in some areas.
Borehole diameter in hard rock Drilling by Down The Hole Hammer (DTH), air flushing.	can not apply with DTH.	4 ½" – 6"	4 ½" – 6"
Moving system itself	can not, but loaded on truck	can not, but loaded on truck	mounted on 4x4 WD truck
Rig assembly	easy to disassembly for transport	light weight	complete unit on truck
Drill system and operation	manually	hydraulic	fully hydraulic
Truck	provide in local	provide in local	provide in local
Shipping information	1.38 ton, 3.75 m ³	one 20 ft container	one 20 ft container
Truck	provide in local	provide in local	TOYOTA Land Cruiser. provide in local

- The above information is for introduction, please contact us for more information.

Water Well Drilling Machines specifications.

Description	ACF/PAT 201	ACF/PAT 301	ACF/PAT 401 LC-PTO
ROTATION Gear box Torque max Speed max	engine driven 24.16:1 20.18kg-m 120rpm	hyd. driven 3.875:1 185.67kg-m 30rpm	hyd. driven 4.75:1 227.60kg-m 0-30rpm
PULL UP Capacity Speed	manual	2063.07kg 12.25m/min	3813.09kg 12.53m/min
PULL DOWN Capacity Speed	manual	2063.07kg 12.25m/min	3813.09kg 12.53m/min
FEED Speed	manual	1.01m/min	1.87m/min
DRILL PIPE Diameter Length	50mm. 1.5m.	76mm. 2.0m.	76mm. 2.0m
MUD PUMP Power Capacity	engine driven 11hp petrol *10 hp diesel 1330L/min2bar *960L/min4bar	engine driven 13hp petrol *10 hp diesel 1330L/min2bar *960L/min4bar	hyd driven 960L/min4bar 960L/min4bar
ROTARY DRILL Bit size	3 ½" – 8"	4" – 8"	4" – 10"
AIR DRILLING Hammer Button Bit size Air compressor Pressure	- - - -	3"-4" hammer 90-150 mm. XA-175 *(H) XA-186,*XAH-146 8-*12bar	4"-5" hammer 90-165 mm XA-175 *(H) XA-186, *XAH-146 8-*12bar
FOAM Power Capacity Pressure	- - - -	engine driven 3.8hp petrol *4.0hp diesel 15L/min 30bar	hyd. driven 10L./min 30bar
HYDRAULIC SYSTEM	-	1pump 1circuit rotary-pull/feed	3pumps 4circuits all system
WEIGHT (rig) without drill accessories	125kg	330kg	1250kg
ACCESSORIES	ground anchorage frame support 4"hand auger	ground anchorage frame support 4"hand auger 2drill pipe key Drill pipe rack Rig casing clamp	hyd. break-out 4stabilizer jack 4extent footing 2night light 2drill pipe key rig casing clamp tools box

- * (option)
- The manufacture reserves the right to make modification without prior notice.

ACF/PAT201 BASIC RIG

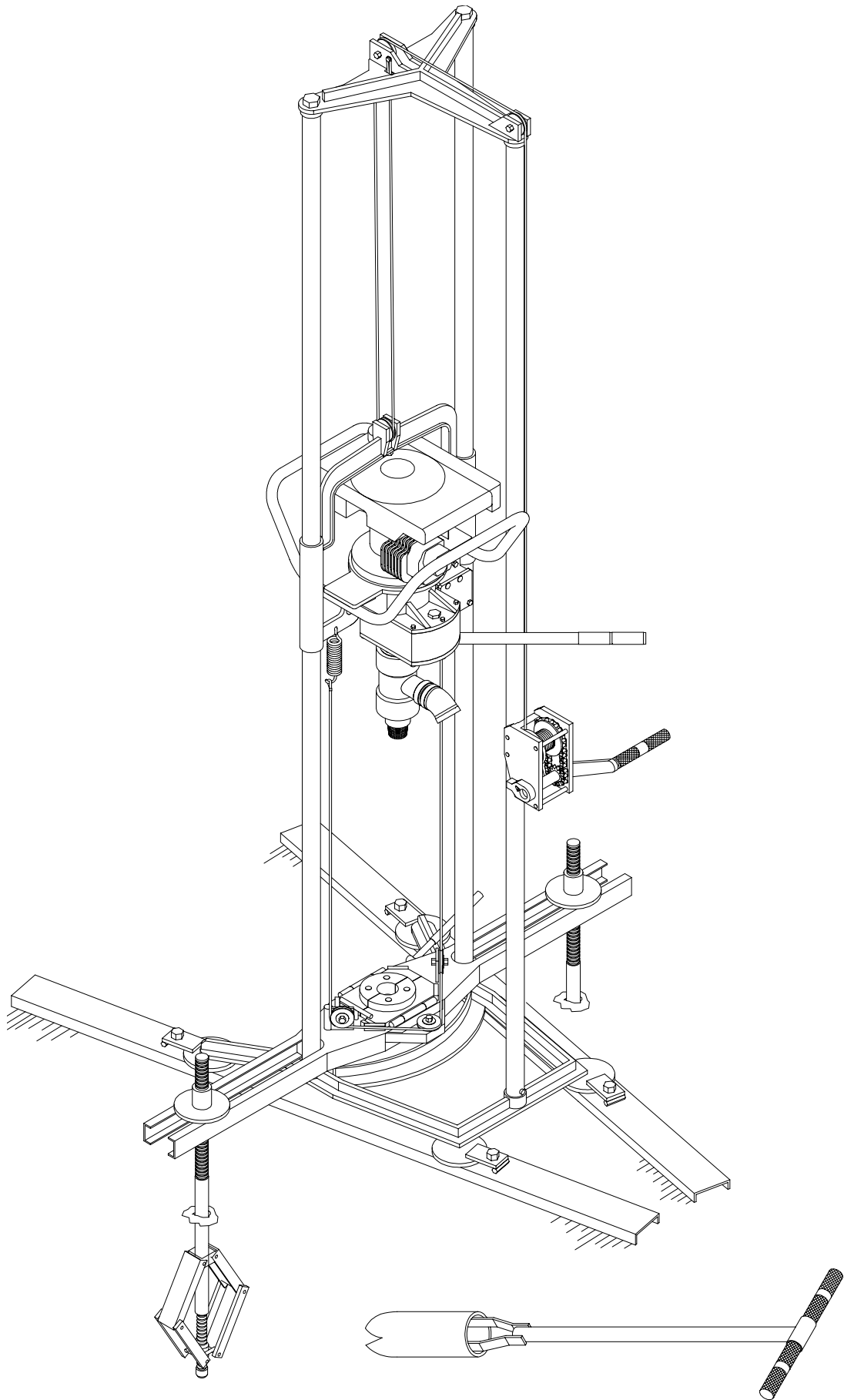

Drill Accessories for ACF/PAT 201

MUD PUMP SET

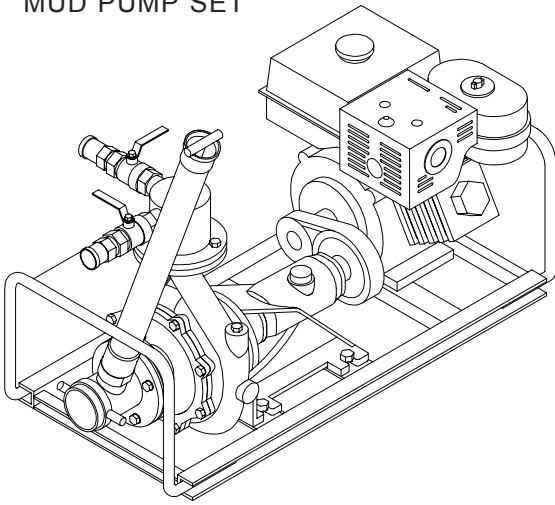

BITS AND SUB ADAPTORS

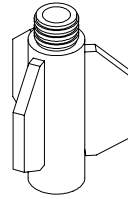

REAMER
"do not supply"

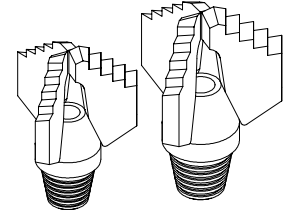

DRAG BIT

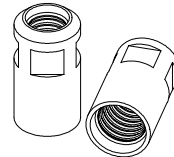

SUB ADAPTOR

BOREHOLE COMPRESSOR

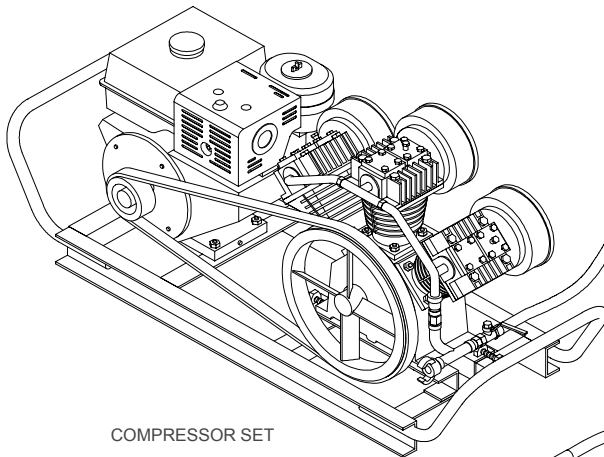

COMPRESSOR SET

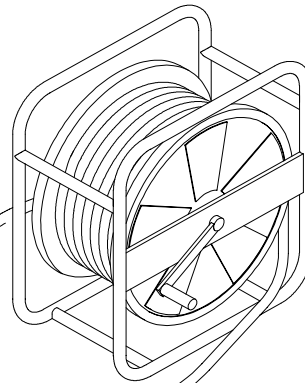

FIEXIBLE AIR HOSE ON REEL STAND

DRILL PIPES

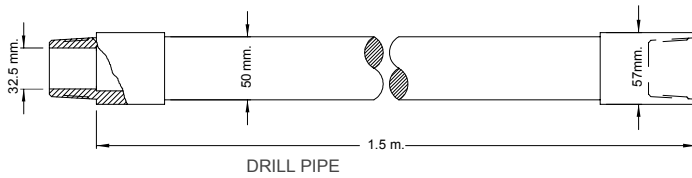

DRILL PIPE

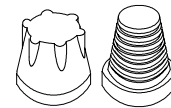

THREAD PROTECTOR
MALE & FEMALE

HAND TOOLS

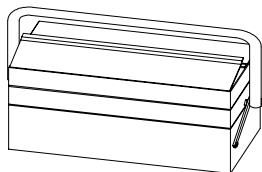

OPERATING TOOL BOX



MALE FISHING TOOL

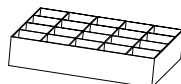

SOIL COLLECTING BOXES



PIPE WRENCH (RIGID)

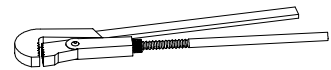

PIPE WRENCH (SANDVIK)

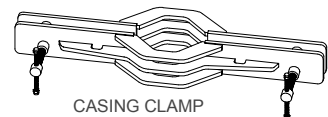

CASING CLAMP

ACF/PAT 301 BASIC RIG

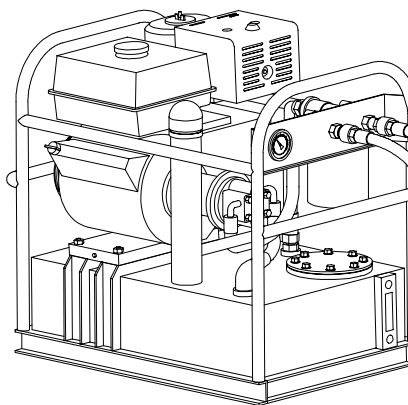
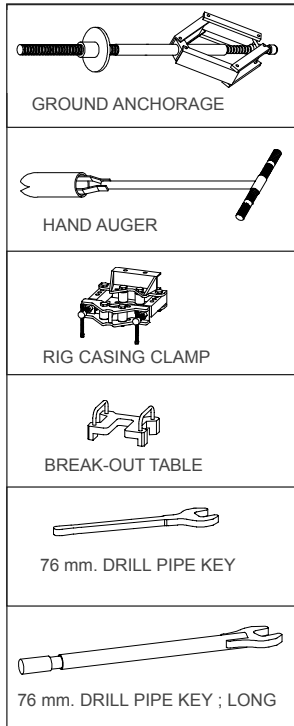

POWER PACK

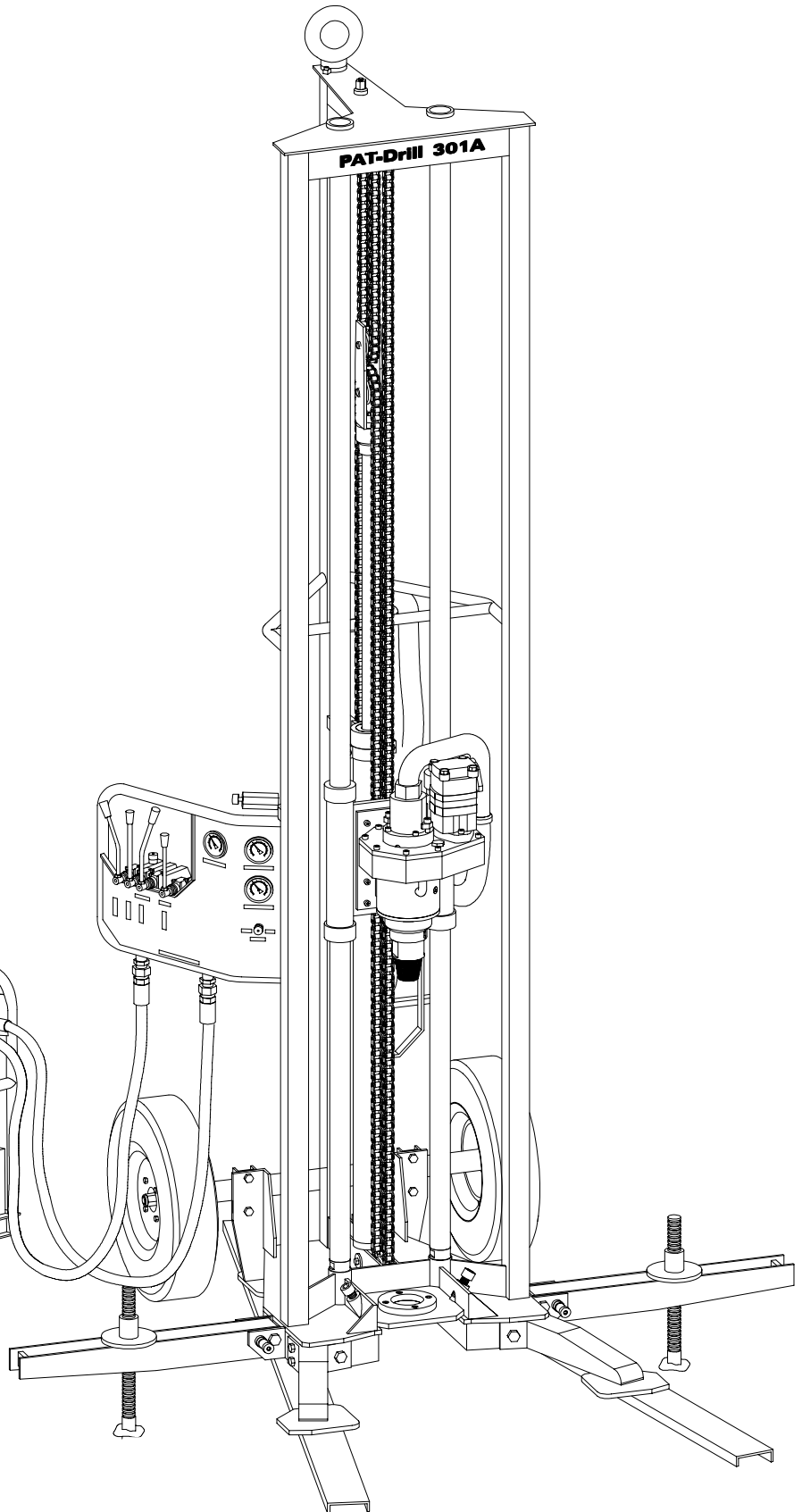

ACF/PAT 301 BASIC RIG

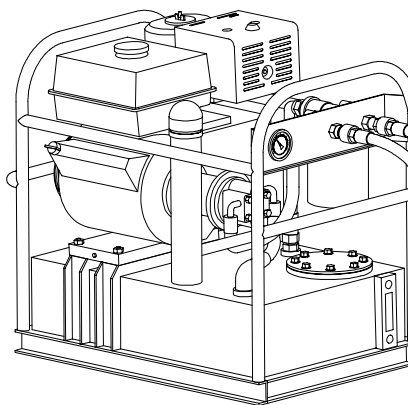
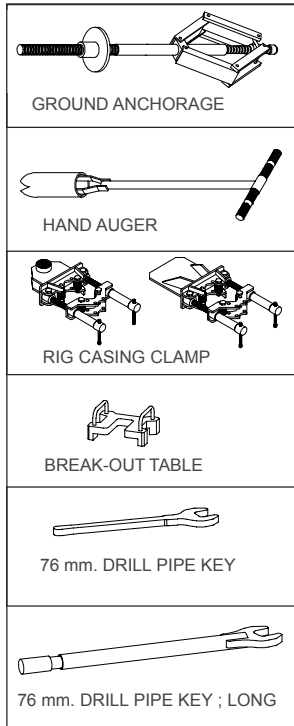

POWER PACK

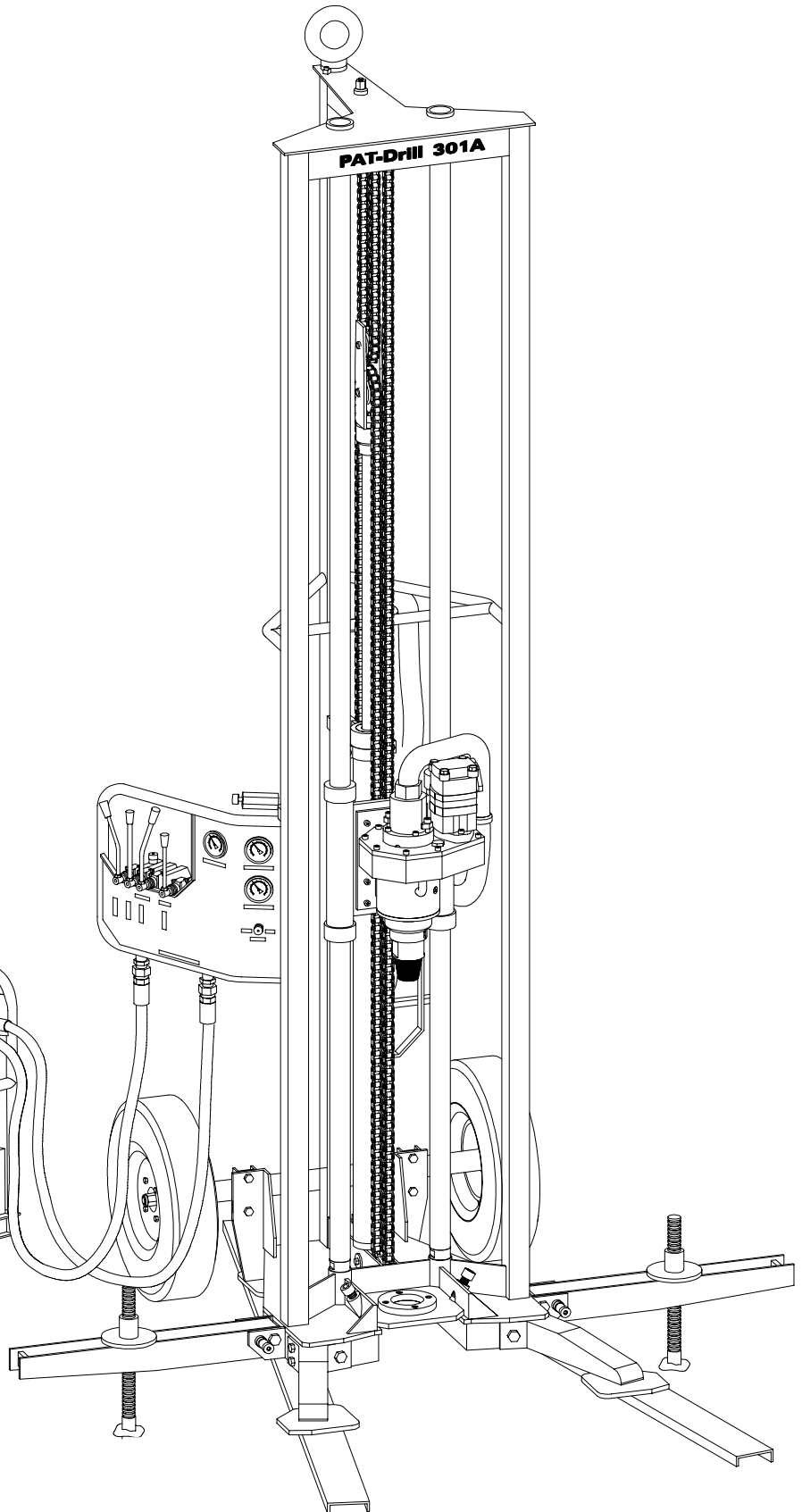

ACF/PAT 401

TOYOTA LANDCRUISER AND 401 BASIC RIG

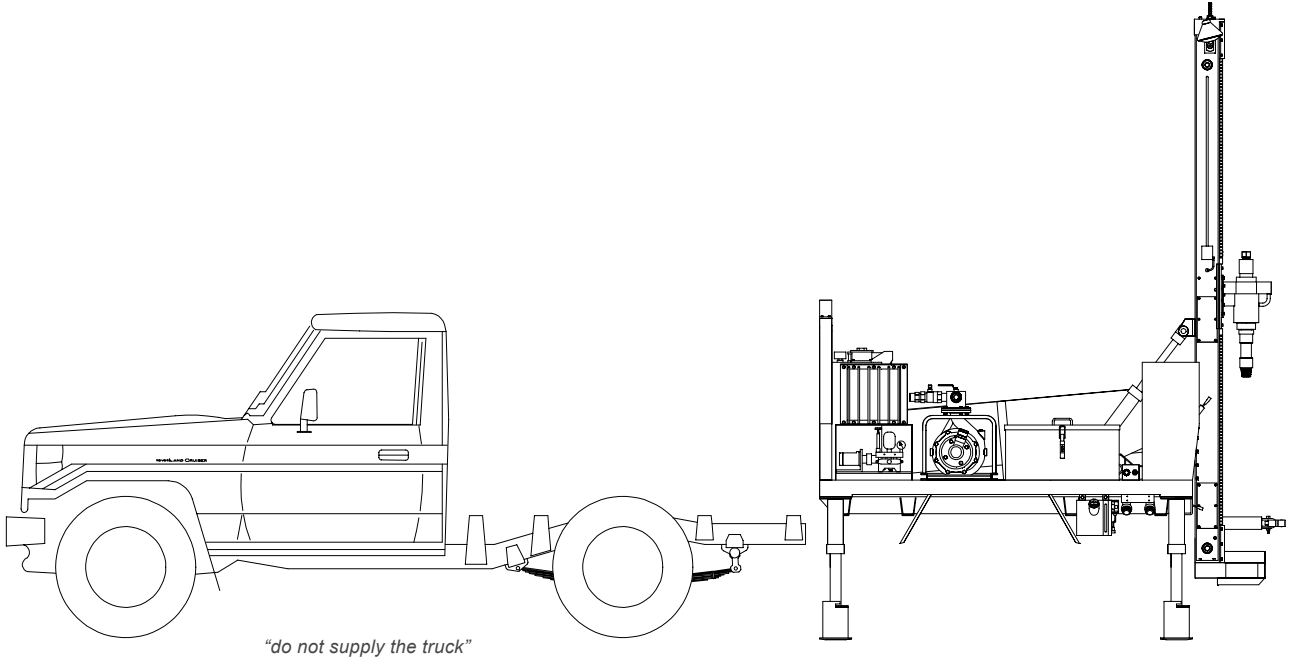

ACF/PAT 401

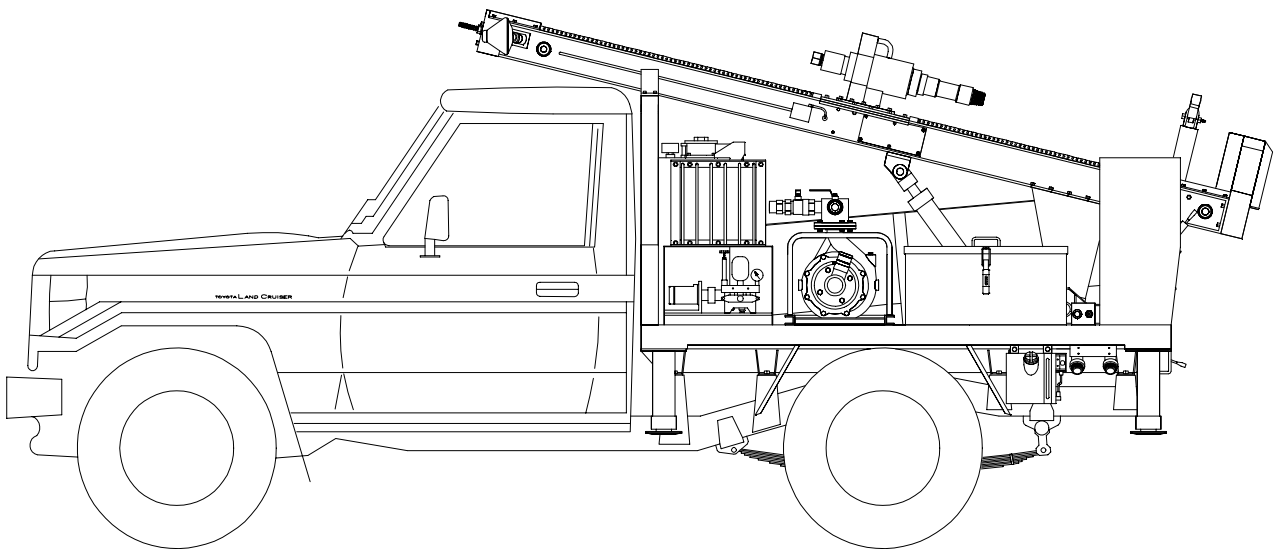

ACF/PAT 401BASIC RIG

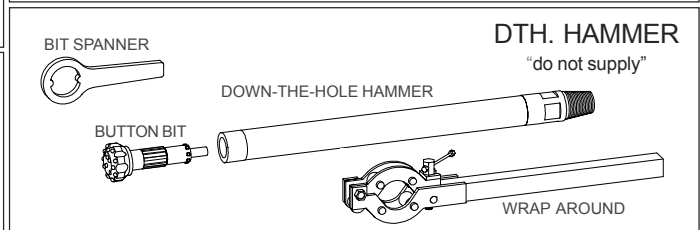
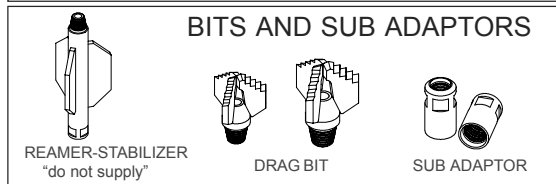
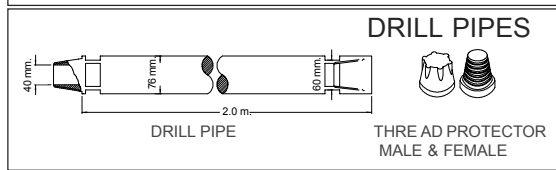
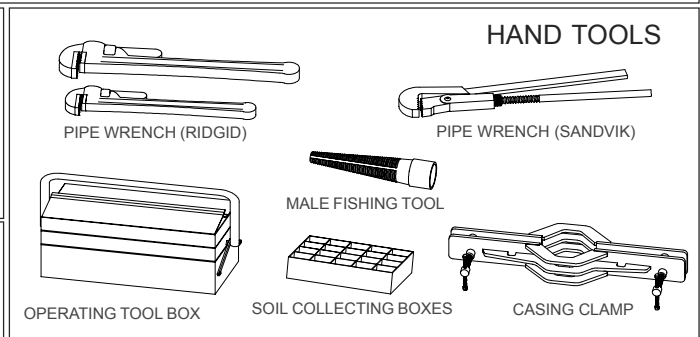
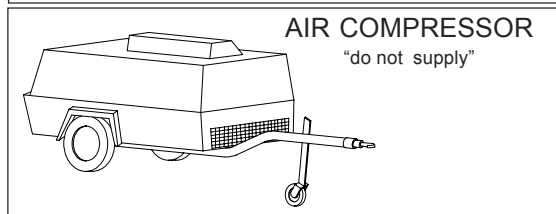
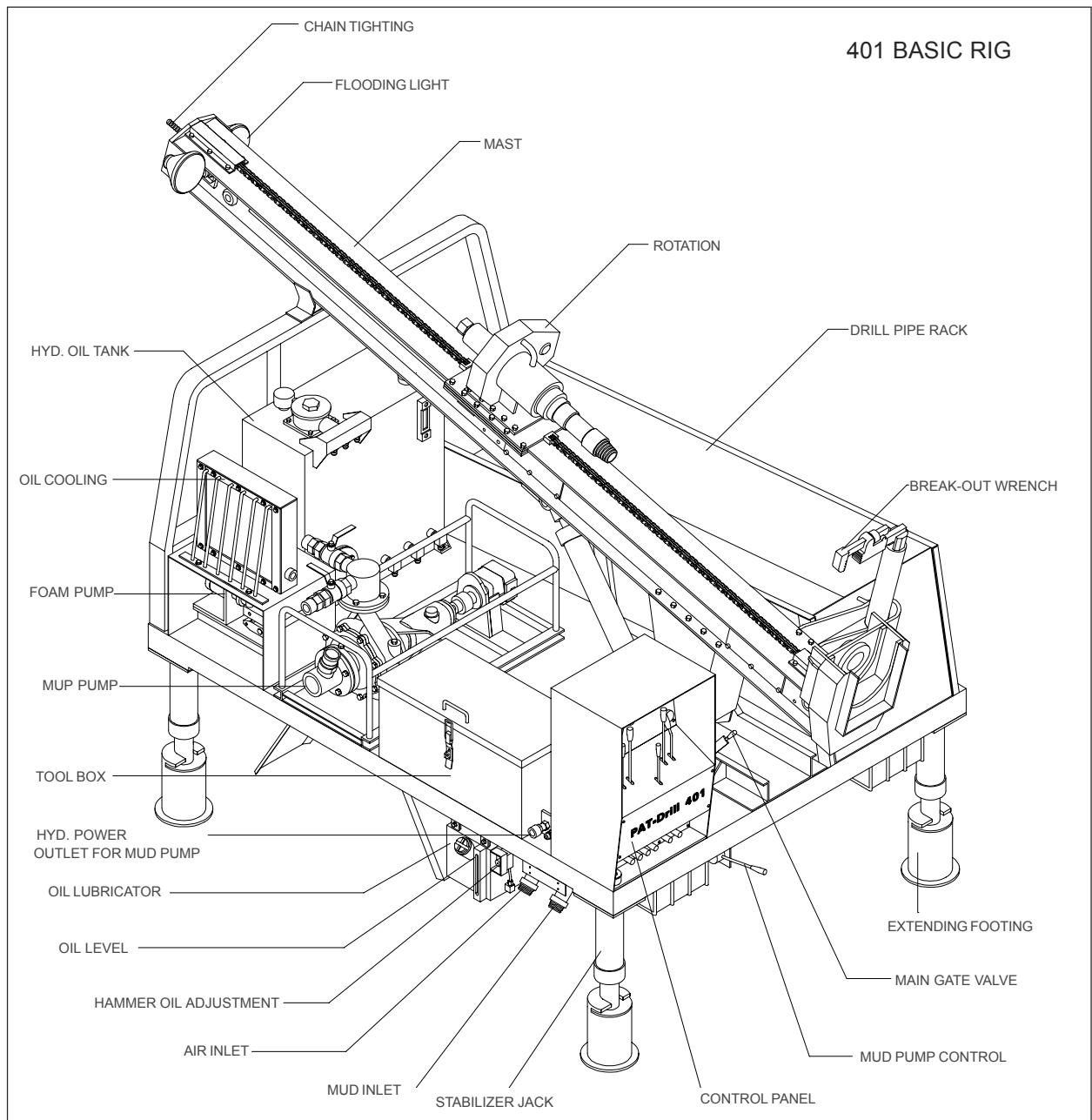

401 THE MODULAR CONCEPT

TRAILER option

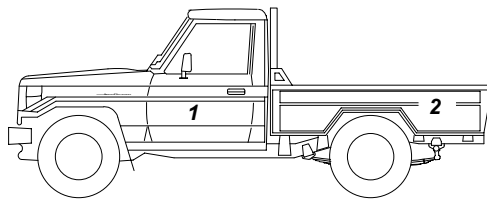

Vehicle Chassis
1&2

New or Used, supplied
by client.

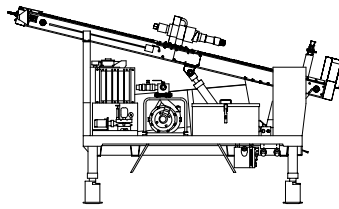

401 Basic Rig
3

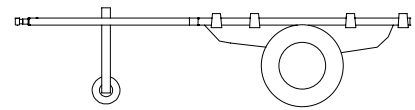

Trailer
4

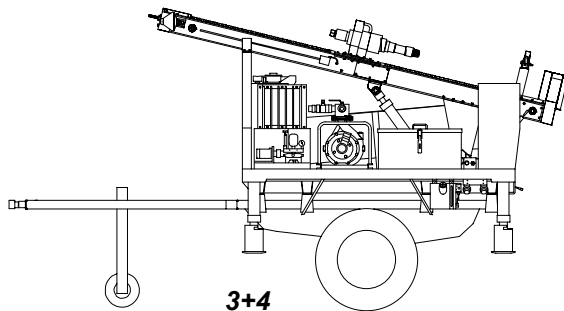

3+4

3+4 The 401 Rig (3) & Trailer (4) are fitted together at the PAT factory to facilitate consolidated and easy delivery to the country of use.

Note: The 401 rig (3) can only be operated after it has been fitted to the vehicle (1) and connected to the vehicle engine

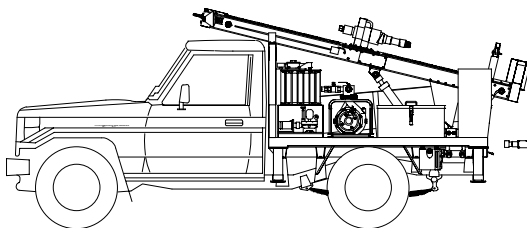

1+3

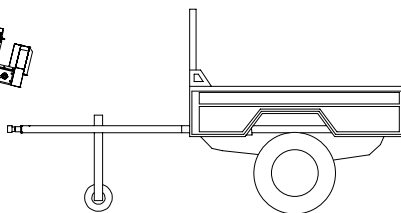

4+2

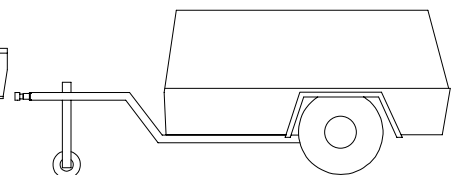

Air Compressor

1+3 To install the 401 (3) first remove the vehicle pick up tray (2) – normally just 6 bolts. Hoist or slide the 1200Kg 401 off the trailer (4) and lower or slide onto the vehicle chassis (1) Align pre-prepared fixing points for re-bolting and fix new drive train connections between the vehicle engine, PAT splitter box and the vehicle back axle.

4+2 The Trailer (4) - 1500Kg load capacity - can then be adapted to meet any number of purposes. The redundant pick up tray (2) can be simply bolted into place to create a general purpose carrier. Alternatively the Trailer (4) could be a base for a skid type air compressor, water tank or any special trailer readily created to meet the specific needs of the drilling operation.

(1+3)+(4+2)+Compressor. It is feasible to tow in a 'train' both a compressor & trailer behind the vehicle mounted 401 – dependant on the vehicle towing capacity and the terrain to be crossed.



PROMOTION OF APPROPRIATE TECHNOLOGY CO.,LTD.

44/5 SOI ATIT, WUTAKARD ROAD, CHOMTHONG, BANGKOK 10150 THAILAND
Phone (66-2) 4761845, 4765313 FAX (66-2) 4765316 Email: pat-drill@a-net.net.th
Authorized distributor in East Africa

PAT AFRICA DRILLING LTD.

P.O. BOX 39838 NAIROBI, KENYA Phone/FAX (254-2) 580146 Email: patafri@afriaconline.co.ke

HYDRAULIC MOBILE MUD PUMP

TAKI 65 - 33/2 Driven by Hydraulic motor

The Hydraulic mobile mud pump is a skid of mud pump driven by a hydraulic motor. The hydraulic motor driven by 2 flexible hydraulic hoses from Power unit.

The pump is 2-stages centrifugal , self priming, to be mounted with 2 Gate valves and Hand primer pump complete with water hoses set.

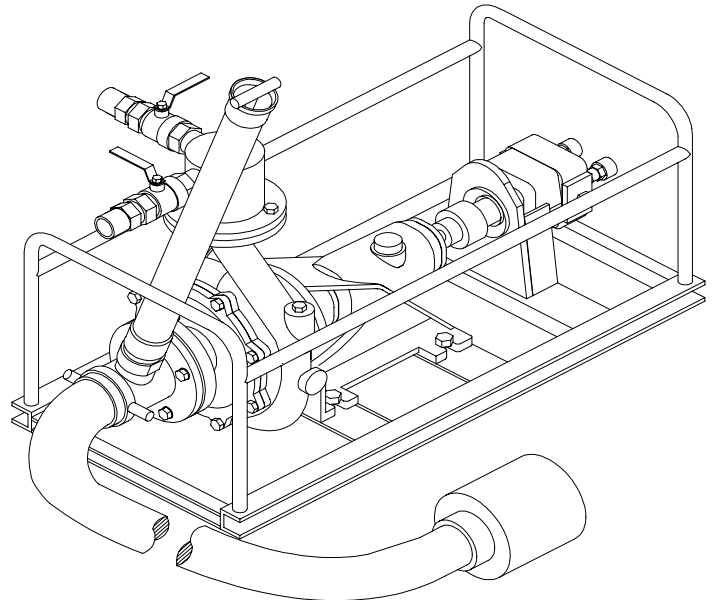
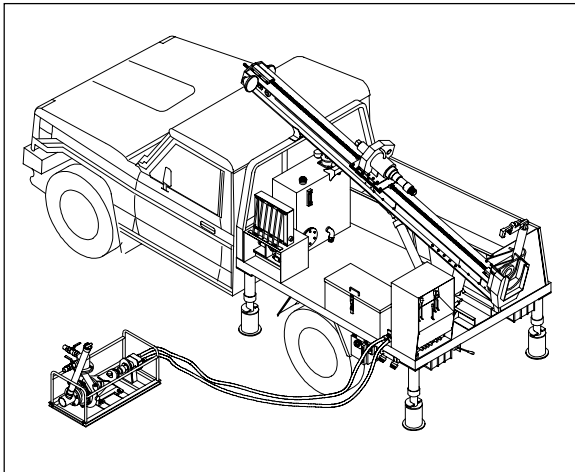

TAKI 65 - 33/2

Technical Specifications

Hydraulic motor :	working at 1800 rpm
Mud Pump Type :	2-stages centrifugal , TAKI model : 65-33/2 Displacement : 1000 litre/min at 30 m 600 litre/min at 50 m maximum pressure : 10 BAR
Weight :	Skid unit : 105 kg
Water hoses :	Suction hose : 3 inch x 4 meter long with coupling Check valve and Filter Injection hose : 1 1/2 inch x 6 meter long Drain hose : 1 1/2 inch x 4 meter long
Hydraulic hoses :	2 of 3/4 inch x 6m. long Flexible hydraulic hoses with quick coupling at each end.

BOREHOLE DEVELOPMENT COMPRESSOR SET

Fusheng TA - 80 Driven by 13 HP Petrol Engine

A dedicated borehole development compressor can be used in place of the main drilling compressor in order to free up the main compressor and drilling rig to move on to the next drilling site. PAT now offers a dedicated, borehole development compressor with an available flexible hose line system which is mounted on a portable, steel reel stand.

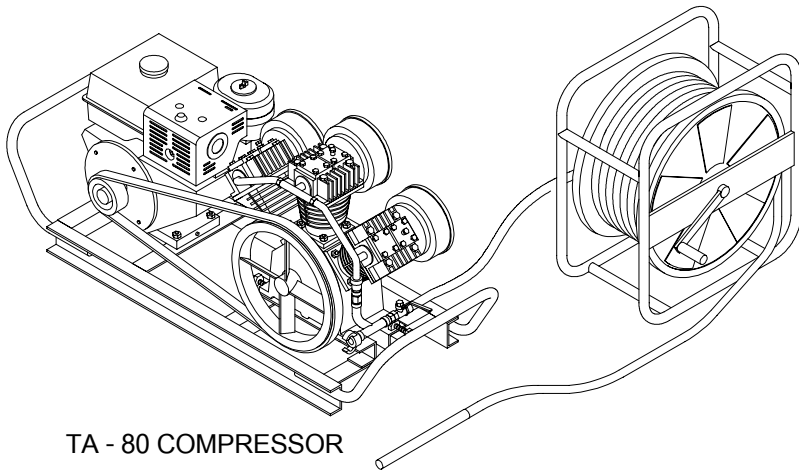

TA - 80 COMPRESSOR

General Specifications

The borehole development compressor is mounted on a steel skid, powered by a 13 HP petrol engine, and mechanically driven by 2 V-Belts (with attached safety guard). Flow rate is hose or pipe.

PAT offers an available flexible rubber hose system with an attached development probe, which is mounted on a steel reel stand. Technical specifications for both the borehole development compressor and flexible rubber hose line system are listed below

Technical Specifications

Borehole Development Compressor

Engine Type:	13 HP HONDA petrol engine, Hand starting, 3600 RPM, Air - cooled
Compressor Type:	Fusheng TA-80, Triplex piston compressor
	Displacement : 27.1 CFM
	Maximum Pressure : 10 BAR
Weight:	Skid unit, 114 kg

Flexible Hose Line System with Reel Stand

Hoses:	1/2 inch x 5 meter flexible rubber hose with connections from reel stand to borehole development compressor
	1/2 inch x 50 meter (or 80 meter) flexible rubber hose with connections and attached development probe.
Reel stand:	Tubular steel frame with detachable steel handle for rolling up the hose line after well development.
Weight:	Reel stand unit, 51 kg (50 m.) and 80 kg (80 m.)



PROMOTION OF APPROPRIATE TECHNOLOGY CO.,LTD.

44/5 SOI ATIT, WUTAKARD ROAD, CHOMTHONG, BANGKOK 10150 THAILAND
Phone (66-2) 4761845, 4765313 FAX (66-2) 4765316 Email: pat-drill@a-net.net.th
Authorized distributor in East Africa

PAT AFRICA DRILLING LTD.

P.O. BOX 39838 NAIROBI, KENYA Phone/FAX (254-2) 580146 Email: patafric@africaonline.co.ke

FOAM INJECTION PUMP SET

Foam Pump Driven by 3.8 HP Petrol Engine

PAT is now offering a Foam Injection Pump system to facilitate drilling operations in the above mentioned geologic settings. The Foam Injection Pump system is mounted on a skid, powered by a small engine,

and mechanically driven by 2 V-belts (with attached safety guard). Pump output is regulated by an engine control device,

and system pressure is regulated by a relief valve and pressure gauge.

The skid mounted system comes complete with a diesel engine, injection pump, hoses and an adjustable flow jet gun. Technical specifications are listed below.



Technical Specifications

- Engine Type :** 3.8 HP Honda Petrol engine, Hand starting, 3600 RPM, Air - cooled (4.0 HP Yanmar Diesel engine is also available)
- Pump Type :** 3 Cylinder Tri-plex Piston Pump
Displacement: 20 liters/minute (5 GPM)
Maximum Pressure: 35 BAR
- Hoses :** 25 mm X 2 meter (minimum length) suction hose and strainer used for drawing water/foam from a tank or drum placed on the ground near the Foam Injection Pump.

6 mm X 20 meter washoff hose line with adjustable flow jet gun and connections to the injection pump for cleaning the drilling rig and equipment.
- Jet Gun :** Adjustable flow jet gun with connections to fit the above hose line.
- Skid Weight :** 71 kg (petrol engine), 81 kg (diesel engine)



PROMOTION OF APPROPRIATE TECHNOLOGY CO.,LTD.

44/5 SOI ATIT, WUTAKARD ROAD, CHOMTHONG, BANGKOK 10150 THAILAND
Phone (66-2) 4761845, 4765313 FAX (66-2) 4765316 Email: pat-drill@a-net.net.th
Authorized distributor in East Africa

PAT AFRICA DRILLING LTD.
P.O. BOX 39838 NAIROBI, KENYA Phone/FAX (254-2) 580146 Email: patafric@africaonline.co.ke

MUD PUMP SET

TAKI 65 - 26 Driven by 13 HP Petrol Engine

The Mud pump set is mounted on a steel skid, powered by a 13 HP Petrol engine, and mechanically driven by 2 V-belts.

The pump is centrifugal, self priming, to be mounted 2 Gate valves and Hand primer pump complete with Hoses set.

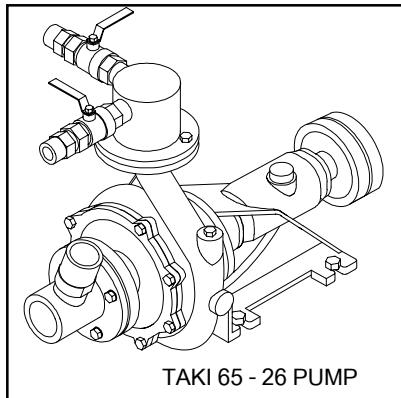

TAKI 65 - 26 PUMP

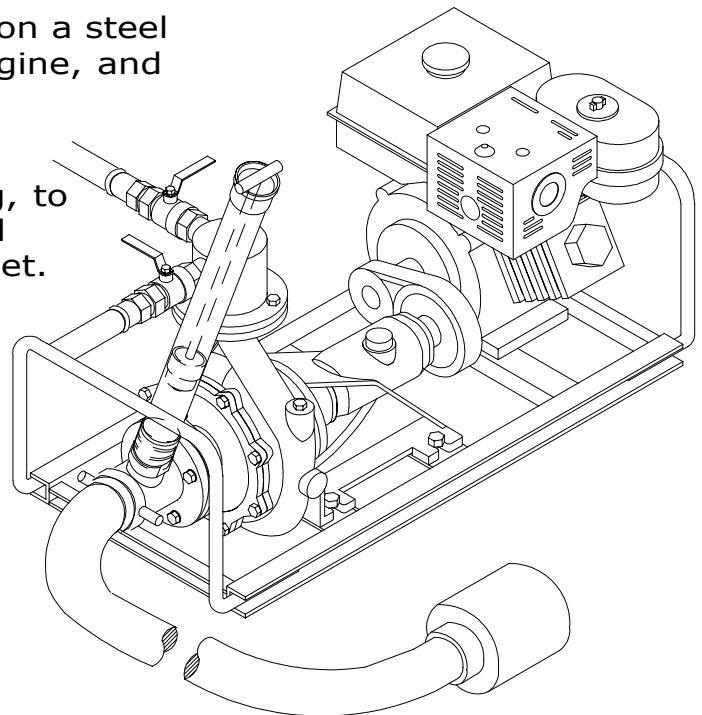

TAKI 65 - 26

Technical Specifications

Engine Type :	13 HP Honda Petrol engine Hand starting 3600 RPM. Air - cooled
Mud Pump Type :	Centrifugal pump type, TAKI model : 65 - 26 Displacement : 240 GPM. at 40 meter Head Maximum Pressure : 10 BAR
Weight :	Skid unit : 134 kg
Hoses :	Suction hose : 3 inch x 4 meter long with coupling Check valve and Filter Injection hose : 1 1/2 inch x 6 meter long Drain hoses : 1 1/2 inch x 4 meter long
Shipping Data :	Gross weight complete set : 198 kg Case dimension : 66 x 122 x 72