

OPERATING INSTRUCTIONS

01.11.SO HAND AUGER SET FOR HETEROGENEOUS SOILS



Contents

On these operating instructions	2
Introduction	2
1. Description	2
1.1 Edelman auger	2
1.2 Riverside auger	3
1.3 Auger for stony soils	3
1.4 Spiral Auger	3
1.5 Piston Sampler	4
1.6 Gouge Auger	4
1.7 Accessories	4
2. Technical specifications	4
3. Safety instructions	5
4. Preparing for use	5
5. The use of augers	6
5.1 General instructions	6
5.2 Edelman auger	7
5.3 Riverside auger and auger for stony soils	8
5.4 Spiral auger	8
5.5 Piston sampler	8
5.6 Gouge auger	9
5.7 Accessories	9
6. Application	10
7. Troubleshooting	10
8. Maintenance	11

On these operating instructions



If the text follows a mark (as shown on the left), this means that an important instruction follows.



If the text follows a mark (as shown on the left), this means that an important warning follows relating to danger to the user or damage to the apparatus.

Introduction

The hand auger set for heterogeneous soils consists of a number of types of augers held in a transport case. An auger consists of a bottom part with auger body to which a handle and optional extension rods can be attached. Contrary to the single type auger this set is suitable for almost any type of soil. It is lightweight and easy to manipulate by a single person.

Upon erosion of rock soils are formed and transported by natural processes to be deposited elsewhere. Soils consist of minerals, organic material and cavities filled with air and/or water. The minerals may vary in size of clay and loam (< 63 µm) and sand (63 µm – 2 mm), to gravel (2 - 63 mm) and stones (> 63 mm). Soil in its natural position may consist of various types of soils (stratified or heterogeneous soil). Differences in texture or soil-forming processes lead to stratification. Soils type will vary from clay, loam, sand to stony soil, depending on its loam and sand content. Peaty soil mostly consists of organic material. Cohesive soils are wet clay, loam and peaty soil. Sand and stony soils are moderately cohesive.

The hand auger set for heterogeneous soils is suitable for manual augering and sampling in a wide variety of soil types for the purpose of general soil research (profiles, geology and mineralogy) and sampling in environmental research. Depending on the water table, structure and type of soil, augering can be done up to a depth of 5 m. Augers are available for any type of soil above or below the water table, and may be selected to adjust to the situation at hand. It is possible to switch augers in the process (see 5. The use of augers).

1. Description

The hand auger set for heterogeneous soils is available as a full standard set for augering up to 5 m of depth, containing bottom parts and various auger bodies, extension rods, handles, a push/pull handle, utility probe, maintenance kit and various accessories in an aluminium transport case (see picture, page 1). The full set weighs 26.4 kg.

1.1 Edelman auger

The Edelman auger body (see picture, next page) is conical in shape and consists of two blades (1) joined in a bit (2). The top of the blades is welded to a bracket (3), which is connected to the auger rod (4). The blades are vaulted and when entering the soil the sample is dug up and evenly guided into the inside of the auger body. The vaulting of the blades not only promotes digging up but also ensures a firm grip of the sample while permitting easy emptying of the auger body.

All Edelman augers in the set have an identical diameter (measured diagonally between the blades at the broadest part of the auger body). The various Edelman augers vary in blade breadth and shape of bit, viz.:

- Clay type
- Combination type
- Sand type
- Coarse sand type

The Edelman auger, clay type.

Clay soils can be very cohesive; therefore, the blades of the clay type can be narrow. The blades meet with little resistance permitting augering to be done with a minimum of effort, producing a hardly disturbed sample. Wider blades would cause extra friction and the soil material would be difficult to remove.

The Edelman auger, combination type.

The blades of this type are slightly broader and rounder than those of the clay type, permitting a good hold of moderately cohesive soils, while cohesive soils can easily be removed. The bit is elongated allowing easy augering in stiffer soil.

The Edelman auger, sand type.

This type of Edelman auger is suitable for moderately cohesive soils, such as sandy soils. The elongated, twisted bit ensures easy entering. The blades of the sand type are broader than those of the combination type allowing a good hold of the soil.

The Edelman auger, coarse sand type.

This auger is based on the sand type but the blades have extra wings thus forming an almost closed auger that will firmly keep hold of loose soils such as coarse sand or very dry sandy soils.

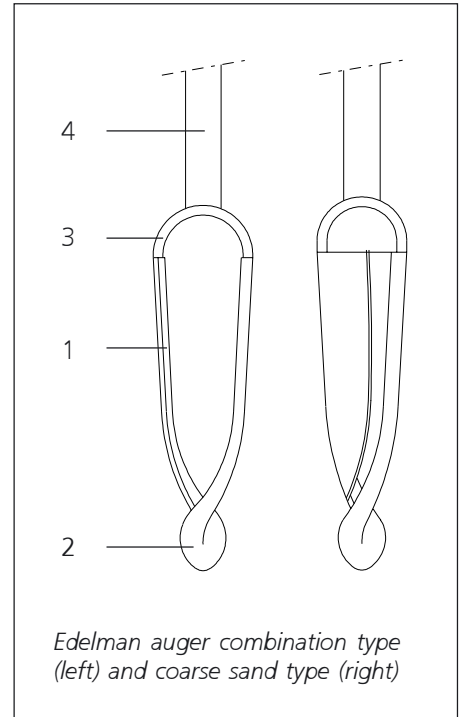

1.2 Riverside auger

Dry and hard soils do not permit the use of the Edelman auger with its centric bit. Therefore, the Riverside auger is being used (see figure). The auger body has an open tube (1) with two beak-like bits at its base (2) and a bow bracket (3) at its top, which connects to the auger rod (4). The extremities of the bits are skewed and scrape the soil, pressing the sample evenly into the tube. The diameter of the auger bits slightly exceeds the tube's diameter so as to reduce friction between soil and tube to a minimum.

1.3 Auger for stony soils

The auger for stony soils is heavier and more rigid than the other types of augers. It has pointed cutting bits, which are bent inward but not touching, rendering certain flexibility. The bits cut downward thus gripping and holding the stones and other less coarse soil material (such as gravel holding coarse sands) between the blades.

1.4 Spiral Auger

Where other augers cannot cope with hard and rigid soils, the spiral auger is ideal (see figure). Its narrow spiral with its negative end (the centre is whetted away, and the two ends are bent) easily digs into the soil pushing stones aside. Its straight design causes friction when hoisting the auger.

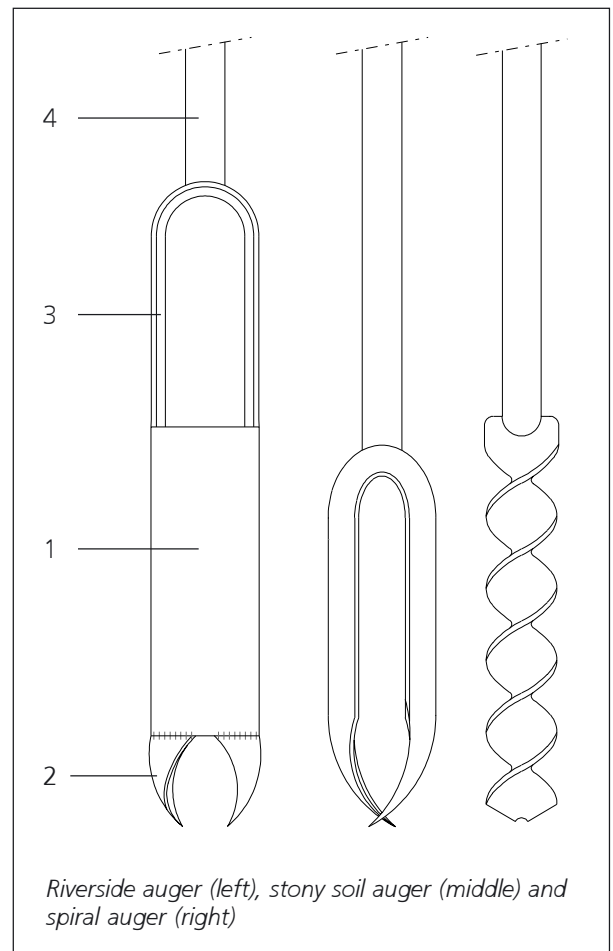

1.5 Piston Sampler

The piston sampler (see figure) is constructed from a thin-walled, 4 cm diameter, stainless steel tube (4). The bottom end is open, whereas the top has a lid (3) through which a stainless steel piston rod (5) can be moved, and outflow openings. The bottom end of the piston rod holds a piston (6), and to its top-end a wire eye (2) is attached. The top-end of the tube is equipped with a bayonet connection (1) welded on its outside to permit free passage of the piston rod. Due to the eccentricity of the sampler one has to reckon with a maximum of 6 cm when working with auger holes. The maximum length of the sample is 75 cm.

1.6 Gouge Auger

The body of a gouge auger is half-cylindrical, with parallel cutting edges running from top to bottom. The auger body is attached to the bottom part at its top end. Its diameter is smaller than that of other augers. The maximum sample size is 50 cm.

1.7 Accessories

Upper part, extension rods and coupling sleeves.

The upper part measures 60 cm and has a detachable, synthetic grip. The extension rods measure 1 m. Since the upper part, the extension rods and bottom parts have bayonet connections, the auger can be adjusted to any length. Coupling sleeves (see figure) are cylindrical and lock the connections.

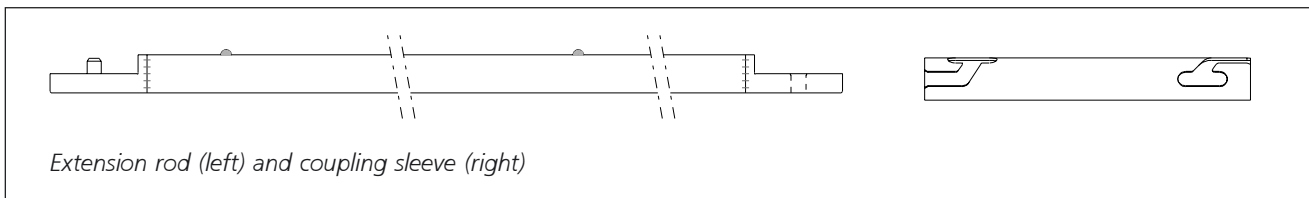
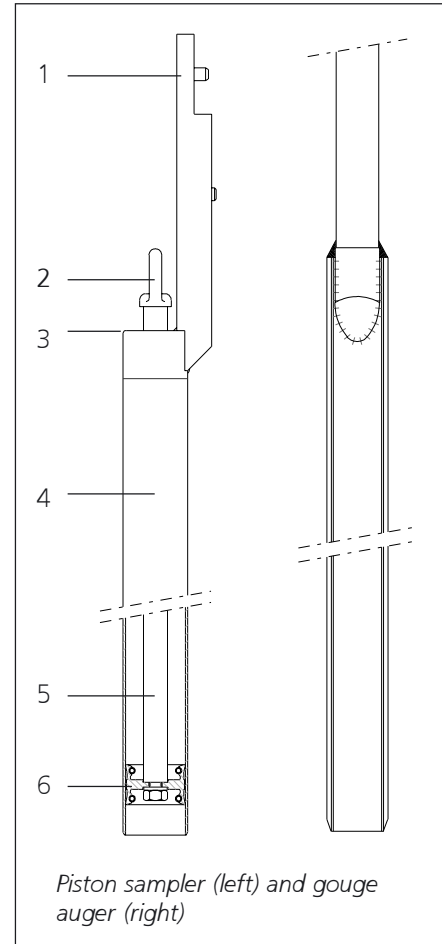

The Push/Pull Handle.

The push/pull handle has two parts that can be fitted around a rod. Once pressure is exercised on the two bars of the handle its construction ensures a firm hold on the rod.

Utility Probe.

The fibreglass utility probe measures 105 cm, and has a 19 mm cone diameter. It is insulated allowing safe checking of the substratum for cables, tubes and pipes.

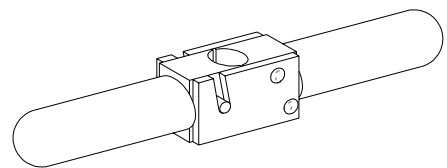

2. Technical specifications

Various important dimensions of different types of augers are listed in the table on the next page. Diameters have been established by diagonally measuring the widest point between the blades.

Type of auger	Diameter (mm)	Blade width (mm)
Edelman clay type auger	70	30
Edelman combination type auger	70	35
Edelman sand type auger	70	40
Edelman coarse-sand type auger	70	75
Riverside auger	70	N/A.
Stony soil auger	70	N/A.
Spiral auger	40	N/A.
Piston sampler	Tube 40 Total 6 cm	N/A.
Gouge Auger	30	N/A.

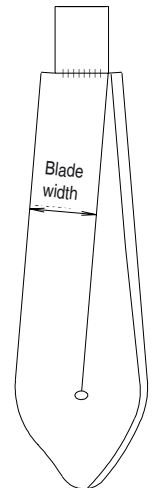

The auger bodies are manufactured in (non-toxic, not stainless steel) iron-manganese steel. The piston sampler is made of stainless steel. All auger bodies are unpainted for the purpose of environmental research.

3. Safety instructions



Hold the coupling sleeve in the middle, this will prevent you from catching the skin of your hands between the parts while (dis)connecting them.



Prior to augering use the utility probe to check for cables, tubes and pipes. If necessary, select another spot to auger.



While augering hold the auger by its synthetic handle. It is fully insulated should you hit an electricity cable.



Augers over 4 m should be handled in parts. This will prevent damage to the rods and reduce the risk of being hit by augers tipping over. This applies to inserting and hoisting the auger.



Do not force, or pound on, the auger. This may cause serious damage, such as cracks or snapped joints.



After augering fill up the borehole with soil or special bentonite plugs. This will prevent humans or animals to trip into the hole and incur injuries, and restores impermeable soil layers.



Be cautious during a thunderstorm. Lightning strokes often occur in the open field, in particular when one holds metal objects.

4. Preparing for use

1. Detach the coupling sleeves from the extension rods and the upper part.
2. Screw the handle into the upper part.
3. Select the appropriate auger (see 6. Application). The Edelman combination type auger often proves to be the best choice.
4. Connect the auger parts (see figure on the next page).
 - 4.1 Hold the coupling sleeve in the middle and slide it onto the upper part until it clicks on the nipple (step 1). The sleeve is locked when it cannot be rotated.

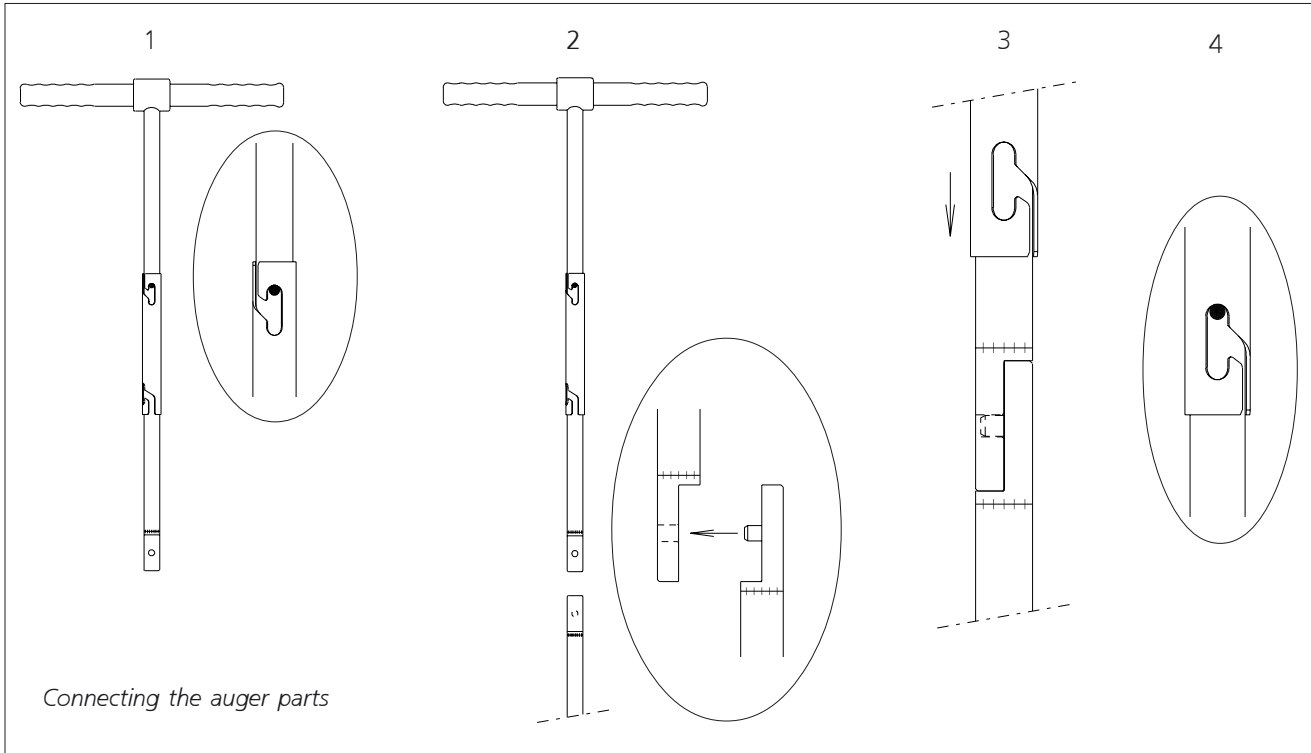

4.2 Join the upper and bottom part (step 2).

4.3 To lock the connection, unscrew the sleeve from the upper part, and slide it across the connection (step 3) and click it onto the nipple (step 4). Check the lock. Notice it will have a slight play.



Hold the coupling sleeve in the middle, this will prevent you from catching the skin of your hands between the parts while (dis)connecting them.

5. The use of augers

5.1 General instructions

Each type of auger has its specific application. However, the instructions below apply to all augers.



Prior to augering use the utility probe to check for cables, tubes and pipes. If necessary, select another spot to auger.



While augering hold the auger by its synthetic handle. It is fully insulated should you hit an electricity cable.



Rotate the auger clockwise.

- Hold the auger perfectly vertical while drilling.
- Over 1,20 m extension rods should be used:
 1. Place the auger flat on the ground near the borehole.
 2. Slide the sleeve off the bottom part, and lock it onto the upper part.
 3. Detach the upper and bottom part.
 4. Select an extension rod and a sleeve. Lock the sleeve over the bayonet at the bottom end of the extension rod (the open end).
 5. Attach the upper and bottom part to the extension rod.



Always check the coupling sleeves. Well-attached sleeves will prevent jamming or loss of parts when augering.

- An auger over 4 m should be inserted and hoisted in parts:
 1. Insert the auger in the borehole and place the bottom part on end for approximately 50 cm. Grip the auger firmly!
 2. To attach: connect the two parts, and slide the sleeve of the upper part across the connection and lock it onto the bottom part.
To detach: slide the sleeve upward and lock it onto the upper part. Unclamp the upper and bottom part.



Augers over 4 m should be handled in parts. This will prevent damage to the rods and reduce the risk of being hit by augers tipping over. This applies to inserting and hoisting the auger.

- The auger's depth is indicated by marks. Small nipples on the bottom part indicate 50 cm from the bottom end of the auger. The piston sampler has no marking and the gouge auger has a small nipple at 75 cm. The upper part has a larger nipple indicating a depth of 1 m, except for the piston sampler and gouge auger, however, where it indicates a depth of 1.35 and 1.25 m respectively. Additional meters depend on the number of extension rods.
- To obtain an undisturbed sample rotate the auger clockwise without pushing, this will cause the sample to detach from the soil.
- To withdraw the auger after sampling, pull it upward while turning it (not when using the Riverside auger or the auger for stony soils). Keep your back straight and your knees bent to prevent injuries. Wear gloves for a full grip on the rods.
- Place the samples in a logical order of augering to allow examination.
- Should you encounter various types of soils, switch to other types of augers (see 6. Application).



Do not force, or pound on, the auger. This may cause serious damage, such as cracks or snapped joints.



After augering fill up the borehole with soil or special bentonite plugs. This will prevent humans or animals to trip into the hole and incur injuries, and restores impermeable soil layers.



Be cautious during a thunderstorm. Lightning strokes often occur in the open field, in particular when one holds metal objects.

- Clean the parts of the auger by rinsing them after use. This will prevent jamming of the sleeves or the piston sampler to leak (see 8. Maintenance).

5.2 Edelman auger

Hold the auger by its handle and rest it on the ground (see figure, next page). Rotate it clockwise while gently pushing it into the soil. Upon $2\frac{1}{4}$ complete rotations of 360° the auger should have dug 10 cm. The auger body will be filled up to its bracket with slightly disturbed soil material. Depending on the type of soil additional rotations may be necessary.

Withdraw the auger after sampling; hoist it while gently rotating the auger. To release the cohesive material hold the auger askew on the surface (see figure, next page), rotate the auger 180° while pressing it into the ground. The sample should detach itself and can be taken out by hand or by lightly tapping the auger. Moderately cohesive material will detach itself immediately. Now, examination is possible.

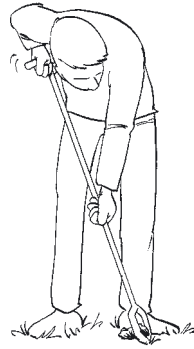
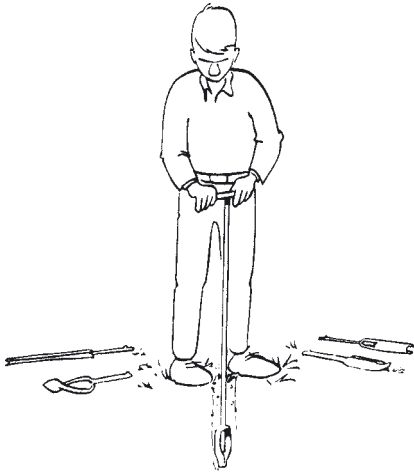

Augering (left), emptying (middle) and examination (right)



Caution:

- ❑ Do not overfill the auger body. Superfluous material will coat the auger hole, which hinders pulling out subsequent soil samples. When augering under the water table an overfilled auger acts like a plunger, which hampers hoisting the auger and results in loss of sample material.
- ❑ Loss of sample material. Hoist the auger with sample while lightly rotating it, do not pull it straight out.

5.3 Riverside auger and auger for stony soils

Screw the auger into the soil. The soil will be fed evenly into the body. Pull out the auger without rotating it. Tap it gently on the surface and the sample will detach itself. In cohesive soils it is difficult to empty the Riverside auger, consequently another type (the Edelman auger) is recommended.

5.4 Spiral auger

Push and turn the auger into the soil. The auger body will push the stones aside. Hoist the auger lightly rotating it. In certain types of soils its design may cause considerable friction. The sample will often be disturbed. The spiral auger is often used to penetrate hard layers before other type of augers can be used.

5.5 Piston sampler

1. Attach a polyester cord to the piston sampler's wire eye and let the (extended) auger down to the bottom of the augered hole. The piston rod should remain in the lowest position. By shaking the piston rod it will fall to its lowest position.

2. Pull the cord attached to the wire eye of the piston rod and an underpressure will be created below the piston.

3. Push the tube steadily down (see figure) while keeping the cord (and the piston) stationary, i.e. at a constant distance to the sample material.



Pressing down the tube may cause resistance. Small pulling movements of the cord will cause an increase of the underpressure, thus reducing resistance and disturbance of the sample.

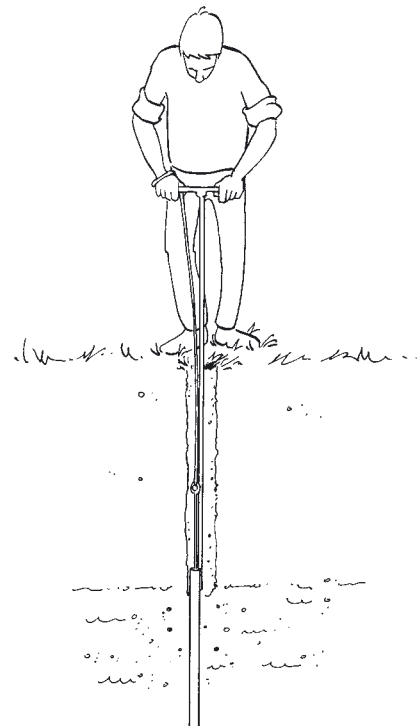

4. When the tube has been filled, push once more and pull it out of the auger hole.



To keep the sample in the tube, the piston should remain in the highest position by keeping the cord taut (if necessary, tie the cord to the handle). Keep the piston rod parallel with the auger rod to prevent the piston to leak, and consequently loss of sample.

5. Place the sampler horizontally on the surface and push the sample out of the tube with the piston. Shaking the tube will facilitate this process. The sample will have a 75 cm undisturbed profile.

Remarks:

- In the case of cohesive soils it is necessary to auger a hole up to a moderately cohesive layer under the water table using another type of auger. Thin and cohesive strata (such as clay or loam up to a maximum of several centimetres) within a moderately cohesive layer may cause clogging of the tube. This impedes pressing the tube into the soil. It is recommended to note the depth of the cohesive layer. Pushing out the sample may cause it to flow as a result of increased water pressure behind the cohesive layer, thus disturbing the sample.
- The piston sampler should be used to sample one auger hole at a time. After sampling the auger hole may cave in and cannot be augered further.
- If the difference in height between the water level in the auger hole and the surface is too large, the sample may flow out of the tube. Filling the auger hole with water can prevent this.

5.6 Gouge auger

Push the gouge auger vertically into the soil without rotating it. Take a sample of maximally 50 cm. Should you encounter resistance completely rotate the auger and press again.

Cut off the sample by completely rotating the auger without pressing down and hoist it gently. Use a bent spatula to cut off protruding soil along the cutting edges (see figure), this will provide an almost undisturbed profile. If necessary the sample can be marked every 10 cm using the marks on the outside of the gouge auger. Wear sturdy gloves emptying the gouge auger. Push out the sample using the bent spatula, the convex part upwards.

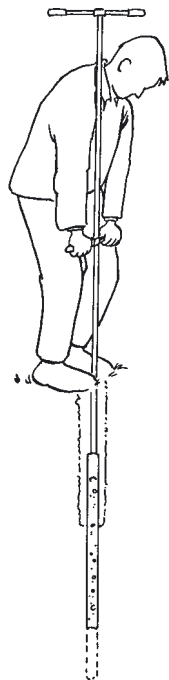
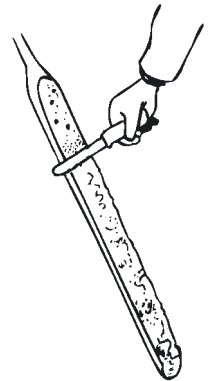

When augering at greater depth, attach extension rods to the upper end of the gouge auger, directly below the upper part. The rods tend to bend following the line of the auger hole. Follow the same order when (dis)connecting the rods.

5.7 Accessories

Push/pull handle.

The push/pull handle is ideal for insertion or withdrawal of the auger without straining your back (see figure). It is clamped around the extension rods at any desired height.

Two persons may also use the push/pull handle. To that purpose clamp the handle perpendicularly to the direction of the auger's top handle. Face the other person holding the bars of the push/pull handle with your right hand and holding the bars of the top handle with your left hand exerting up-or downward pressure.

Sounding device.

The sounding device is used to determine the ground water level in the auger hole. Drop it into the auger hole until it hits the water surface with a 'plopping' sound. The depth is crucial in determining the choice of auger. Note that, depending on the type of soil, it may take some time for the water in the auger hole to level with the water table.

6. Application

The auger set for heterogeneous soils is suitable for augering in almost any type of soil (not in solid rock or very stony soils). There are various auger types for any type of soil. In heterogeneous soils one can switch type of auger. The augers in the set can be used for drilling up to a depth of 5 m, depending on depth of the ground water, soil structure and type of soil.

The Edelman auger can be used in various types of soil. In homogeneous soil one of the four types will suffice. In unidentified or mixed soil types the combination auger will be preferred. In hard or stony soils the Riverside auger or auger for stony soils or spiral auger will be useful. The piston sampler is suitable in sandy soils under the water table, giving an undisturbed profile. The gouge auger also provides an undisturbed profile and is suitable for soft, cohesive soils, above and below the water table.

The table below lists the application of various auger types.

Types of auger	Application
Hand auger set	Soil research in almost any type of soil.
Edelman clay type	Marshy or clay soils above the water table.
Edelman combination type	Universal: clay soils below the water table.
Edelman sand type	Sandy soils above the water table.
Edelman coarse sand type	Coarse sand soils above the water table.
Riverside auger	Hard, rigid soils, such as dry clay soils; fine stony soils.
Stony soil auger	Stony soils, gravely soils containing small stones.
Spiral auger	Very hard, rigid soils such as iron pans, chalk and lime profiles. Particularly suitable to drill through, or to pre-auger in combination with other types of augers.
Piston sampler	Sandy soils below the water table or in open water.
Gouge auger	Soft, cohesive soils such as clay, loam and peaty soil.

7. Troubleshooting

- Soil particles between the augering rod and the coupling sleeve have caused the sleeve to jam. Pour clean water in one direction in the sleeve, this will flush out the particles. Use the synthetic backside of the spatula to tap the sleeve, coarse particles will become loose thereby allowing the sleeve to slide. In winter conditions icing up may cause the sleeve to jam.
- Augering is strenuous. This may be caused by a faulty match of auger and type of soil (see 6. Application), or incorrect augering (see 5. The use of augers).
- Loss of sample during augering. This may be caused by a faulty match of auger and type of soil (see 6. Application), or incorrect augering (see 5. The use of augers).
- The piston sampler leaks, leading to loss of sample. Slide the piston rod up and down parallel with the auger rod to prevent the piston to dislocate. Non-parallel movements can damage the piston permanently. Grains of sands may cause damage and leakage to the piston. Damaged pistons should be replaced (see 8. Maintenance).
- Loss of sample material. The difference in height between the water level in the auger hole and the surface is too large. Fill the auger hole with water.
- Make sure not to lose the coupling sleeves. Count them after augering. Carry them attached to an extension rod or to the upper part. Always check whether the sleeves are locked. Two spare sleeves are provided.

- ❑ Make sure to withdraw every single part of the auger. Always check whether the sleeves are locked.
- ❑ The sounding device does not produce a 'popping' sound when passing the water table. Move it quickly up and down to increase its downward speed. Make a rough estimation of the depth of the water table in the tube and increase accuracy upon every examination.

8. Maintenance

- ❑ It is recommended to keep the augering equipment in good condition by rinsing it during use. Flush out any dirt from the piston sampler by moving the piston rod up and down under water.
- ❑ Clean the augers after use with running water. Take off the coupling sleeves from the rods and the upper parts, clean and dry them well to keep the insides smooth and prevent oxidation (rough inner surfaces of the sleeve may cause it to jam). To avoid excessive oxidation when storing the auger body, apply Vaseline (not for the piston sampler).
- ❑ The piston of the piston sampler can be removed for cleaning. Hold the wire eye and turn the nut on the piston using a (ring) spanner 13. Push the piston rod to remove the piston (slant it slightly) from the tube. Clean the piston, position it in the tube, insert the piston rod, place the spring washer and tighten the nut.
- ❑ The auger bodies need no whetting, use keeps them sharp-edged. Under normal conditions oxidation is not detrimental to the auger and will vanish upon use.

Nothing in this publication may be reproduced and/or made public by means of print, photocopy, microfilm or any other means without previous written permission from Eijkelkamp Agrisearch Equipment.

Technical data can be amended without prior notification.

Eijkelkamp Agrisearch Equipment is interested in your reactions and remarks about its products and operating instructions.