

Water for the World

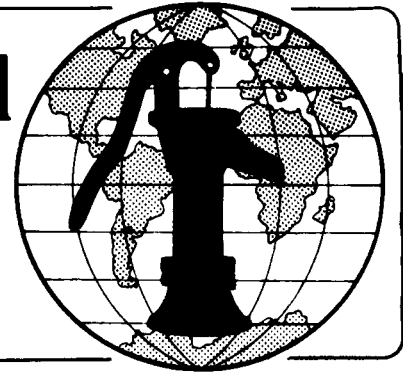

Constructing Bored or Augered Wells Technical Note No. RWS. 2.C.4

Constructing a bored or augered well properly is important to ensure a year-round supply of water and to protect the water from contamination. Construction involves assembling all necessary personnel, materials, and equipment; preparing the site; excavating the well shaft; and installing the casing and screen. Finishing the well is discussed in "Finishing Wells," RWS.2.C.8.

This technical note describes how to construct a bored well. Read the entire technical note before beginning construction.

Useful Definitions

AQUIFER - A water-saturated geologic zone that will yield water to springs and wells.

GROUND WATER - Water stored below the ground's surface.

WATER TABLE - The top, or upper limit, of an aquifer.

Materials Needed

The project designer must provide four papers before construction can begin:

1. Location map similar to Figure 1.
2. Design drawing of the method of installing the casing similar to Figure 2.
3. Design drawing of the well screen similar to Figure 3.
4. Materials list similar to Table 1.

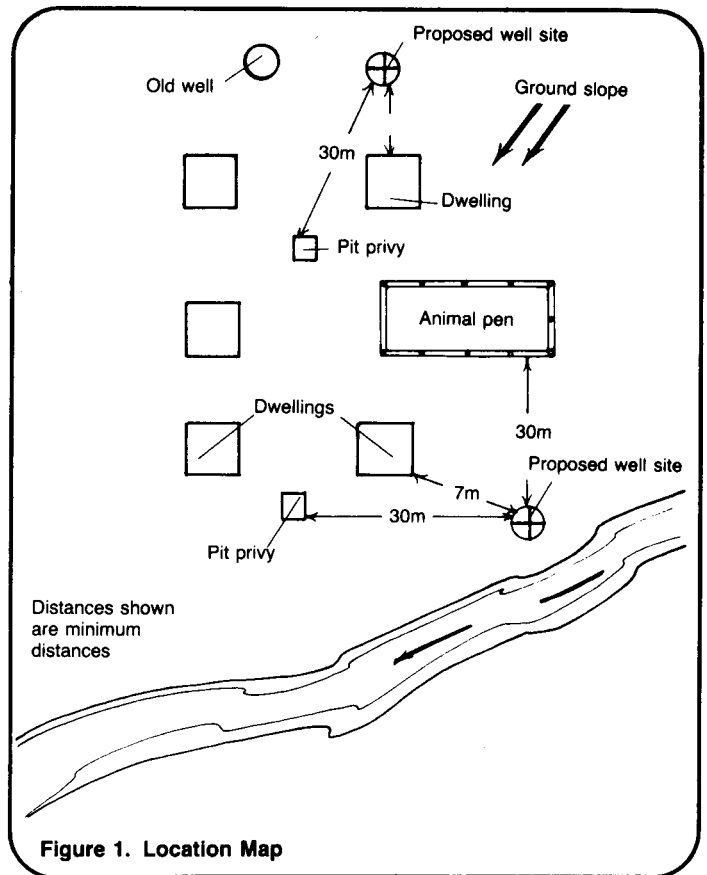

Construction Schedule

Depending on local conditions, availability of materials, and skills of workers, some construction steps will require only a few hours, while others may take a day or more. Read the construction steps and make a rough estimate of the time required for each step based on local conditions. You will then have an idea of when during the construction process specific workers, materials, and tools must be available. Draw up a work plan similar to the sample showing construction steps.

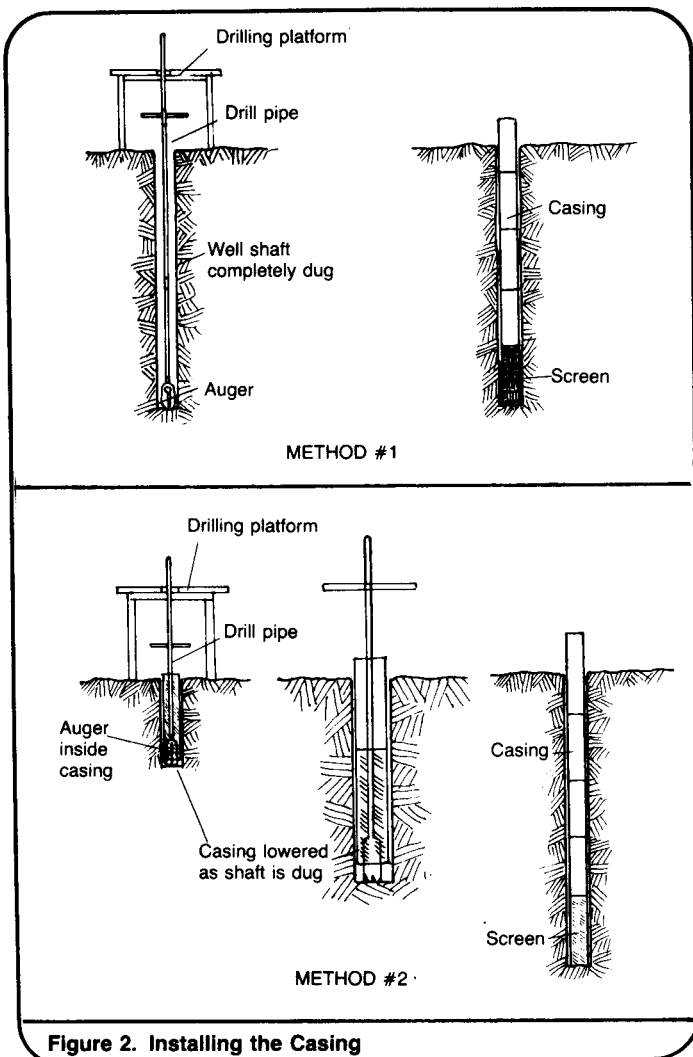

Figure 2. Installing the Casing

Table 1. Sample Materials List for Bored Well

Item	Description	Quantity	Estimated Cost
Personnel	Foreman	1	---
	Workers	3	---
Supplies	Plastic pipe for casing (100mm diameter, 2.0m long)	---	---
	Plastic pipe with slots for screen	---	---
	Cement mix	---	---
	Sealing material	---	---
	Plug for screen	---	---
Equipment	Wooden platform	---	---
	Drill pipe (25mm diameter, 3.0m long)	---	---
	Joints for drill pipe	---	---
	Auger	---	---
	Sand auger	---	---
	Handle (adjustable)	---	---
	Shovel	---	---
	Hammer	---	---
	Hacksaw	---	---
	Wrenches	---	---
	Measuring tape	---	---
Plumb bob and line	---	---	

Total Estimated Cost = ---

Caution!

The well must be bored at the exact location specified by the project designer.

Construction Steps

1. Using the location map and a measuring tape, locate the well site. Clear the area of any vegetation or debris that might interfere with work.

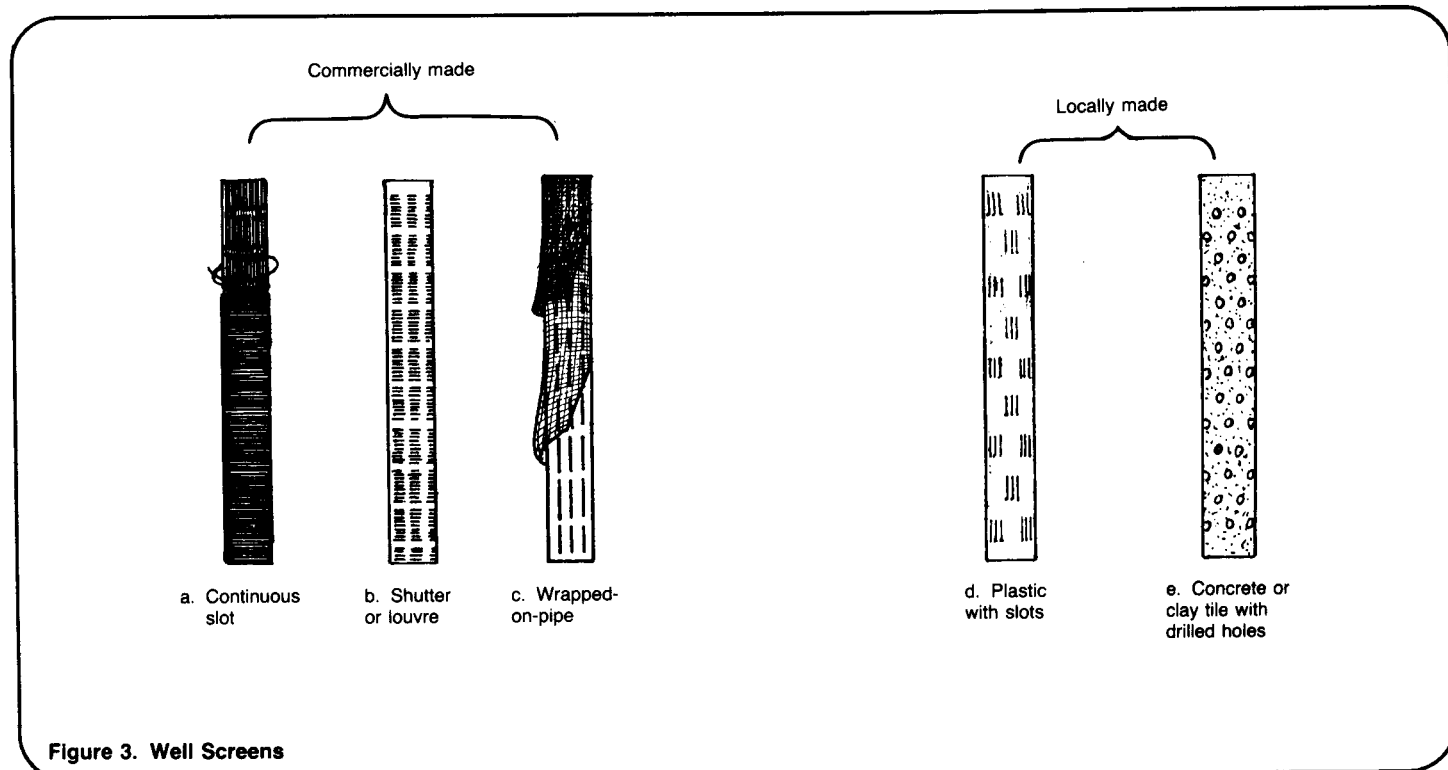

Figure 3. Well Screens

Table 2. Sample Work Plan for a Bored Well

Time Estimate	Day	Task	Personnel	Materials/Equipment
1 day	1	Locate and prepare site; assemble materials	Foreman (present during entire construction); 1-2 workers	Measuring tape; drawings
1/2 day	2	Erect platform; dig starter hole	3 workers	Wood, hammer, saw, nails, shovel
2 1/2 days	2-4	Bore shaft until sides begin to crumble	3 workers	Auger, drill pipe, handle, pipe joints, wrenches
1/2 day	5	Remove auger and drill pipe; lower screen and casing; lower drill pipe with sand bailer	3 workers	Screen, casing, casing sealer, sand bailer
2 1/2 days	5-7	Continue sinking shaft, screen, and casing into aquifer	3 workers	Screen, casing, casing sealer, sand bailer
1 day	8	Pour gravel and concrete mix around outside of casing; remove drilling pipe; install plug	3 workers	Gravel, concrete mix, plug

2. Assemble all laborers, materials, and equipment needed to begin construction.

3. Erect a sturdy platform over the site. The platform legs should be planted firmly in the ground. Mark the exact point where the well will be bored. If the drill pipe is to pass through a hole or notch in the platform, this point can be marked by lowering a plumb bob. Dig a starter hole about 0.5m deep and somewhat larger in diameter than the auger.

4. Attach the auger to the first section of drill pipe and set it in the starter hole. Attach the adjustable handle at about shoulder height. See Figure 4. Use a plumb bob and line to be certain that the drill pipe is vertical. Rotate the auger two or three turns or until it is full of soil, then lift it out of the hole and empty the soil. Use the excavated soil to build a mound around the shaft to drain away surface water as shown in Figure 5.

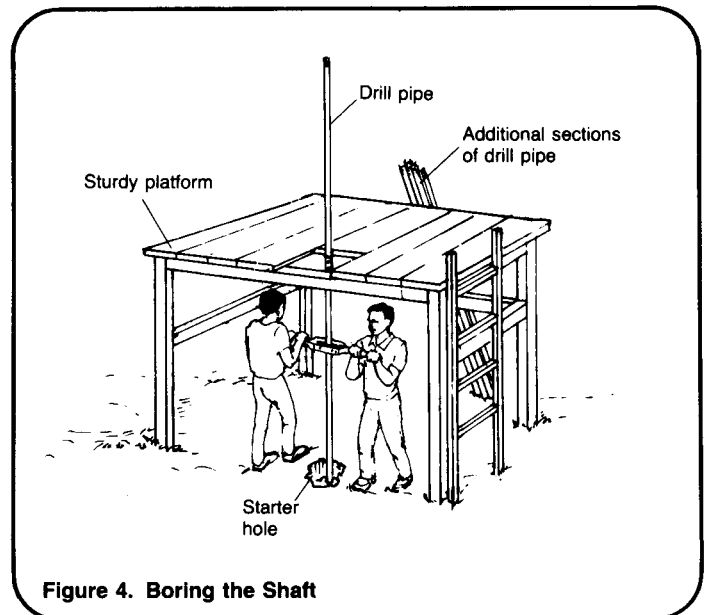

Figure 4. Boring the Shaft

As the shaft is sunk, the handle must be moved up on the drill pipe. When the handle nears the top of the

drill pipe, attach another section of pipe using the pipe joint shown in Figure 6a.

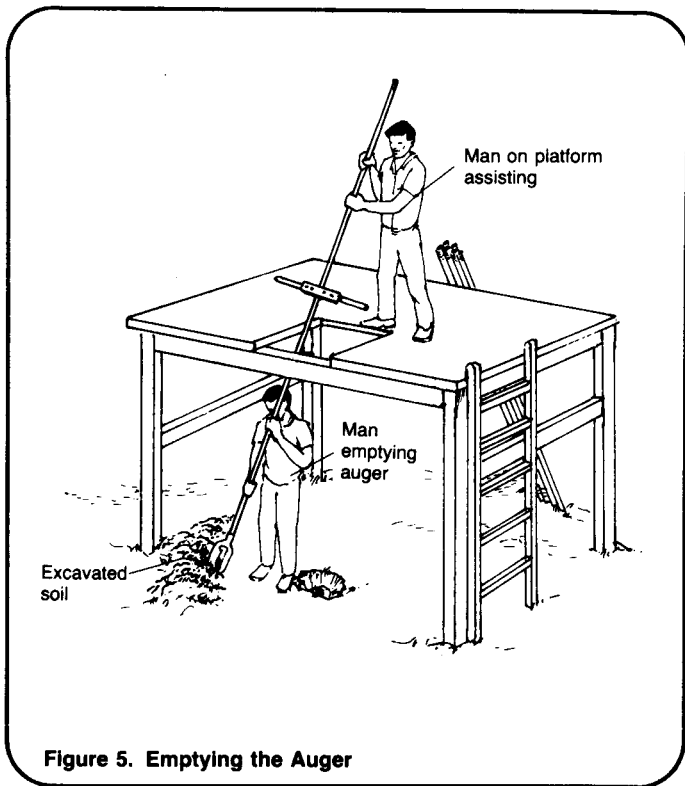

Figure 5. Emptying the Auger

5. When the shaft has been sunk far enough that another pipe section is needed, attach the pipe section with a pipe joint like the one in Figure 6b. Because more than two sections of drill pipe are difficult to handle when raised out of the shaft, continue boring in the following manner:

5a. Rotate the auger until it fills with soil. See Figure 7a.

5b. Raise the drill pipe until joint "B" is at ground level. Slide a support rod through the hole in the joint to prevent the drill pipe from falling into the well shaft. See Figure 7b.

5c. Disconnect the upper section of drill pipe and lean it against the platform. See Figure 7c.

5d. Raise the remaining drill pipe out of the shaft and empty the auger. See Figure 7d.

5e. Lower the drill pipe into the shaft until it is resting on the support rod through joint "B."

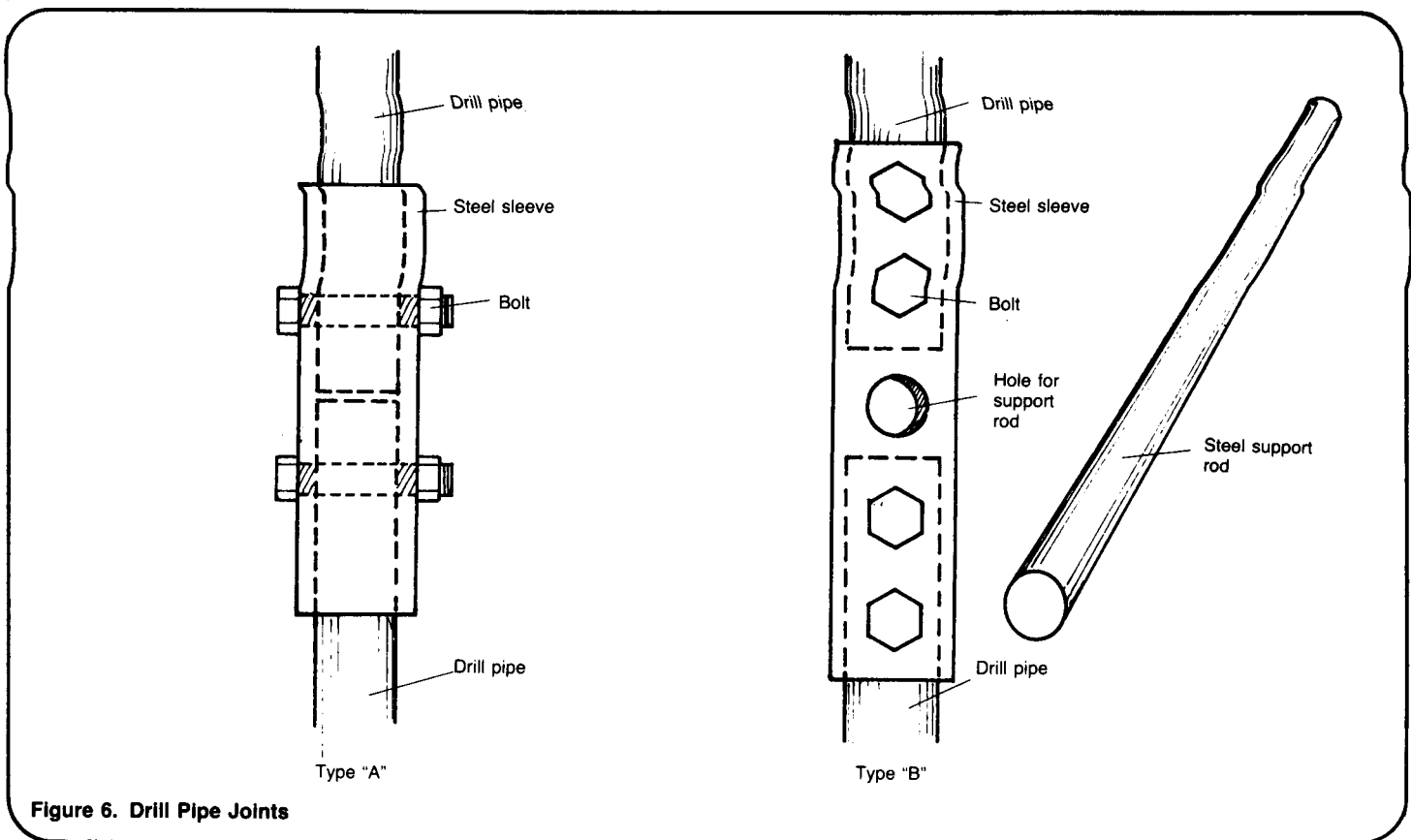

Figure 6. Drill Pipe Joints

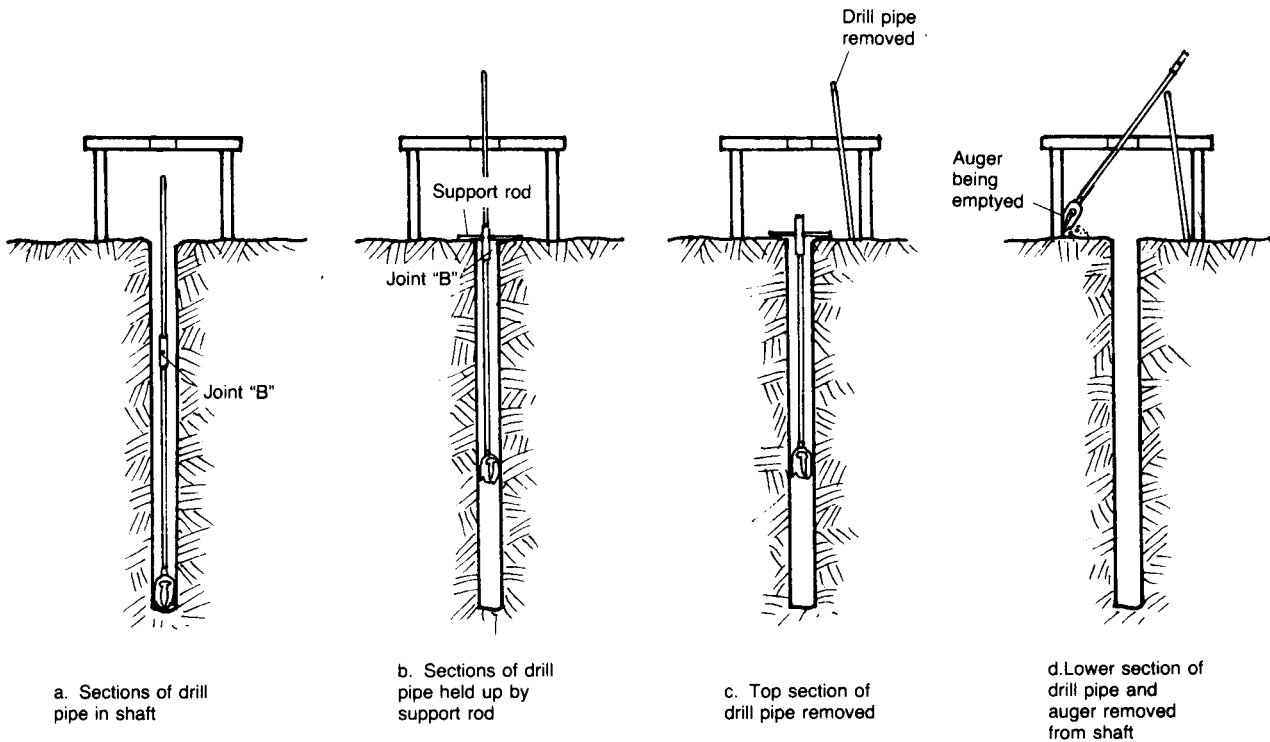

Figure 7. Disconnecting Drill Pipe to Empty Auger

5f. Reconnect the upper section of drill pipe, lower the auger to the bottom of the shaft, and continue boring.

6. If the sides of the shaft tend to cave in or crumble, remove the auger and drill pipe from the shaft. Lower the screen and casing into the shaft. A device for lowering concrete pipe casing is shown in Figure 8. If concrete pipes are used, spread mortar on each pipe section before lowering, and lower the pipe with the bell-end down.

If plastic pipe is used for the casing, the sections are light enough to be joined and bonded together at the surface and lowered into the shaft by hand.

7. Replace the auger with a sand bailer or an auger that fits inside the casing. Lower the bailer or auger and drill pipe into the casing and continue boring. See Figure 9. As the shaft is sunk, the casing will move down and more sections of casing will have to be added on top.

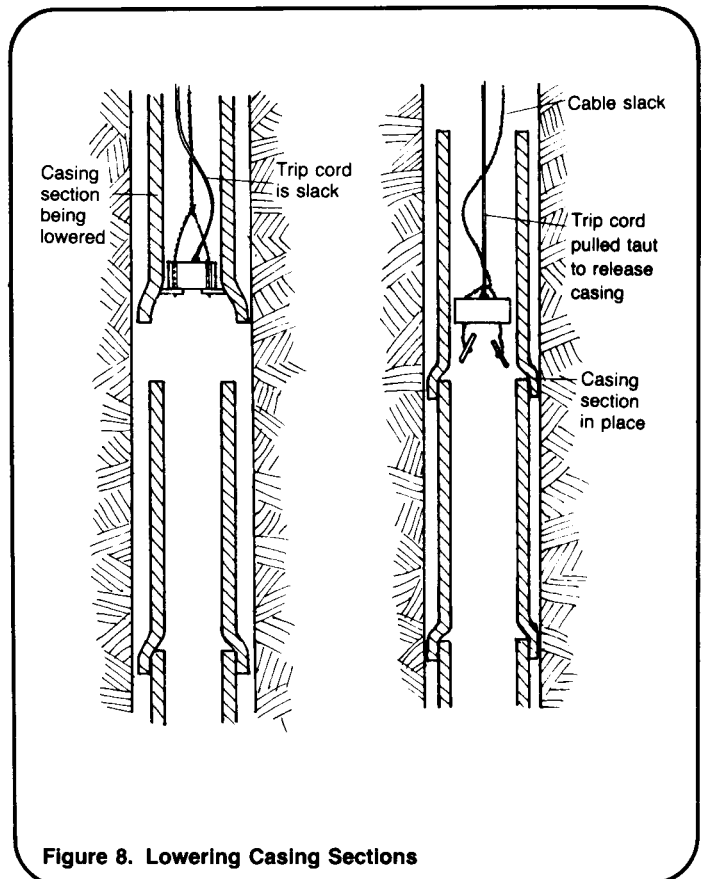

Figure 8. Lowering Casing Sections

