

# Solar (Photovoltaic) Water Pumping

## Introduction

Water pumping has a long history, so many methods have been developed to pump water with a minimum of effort. These have utilised a variety of power sources, namely human energy, animal power, hydro power, wind, solar and fossil fuels for small generators. The relative merits of these are laid out in Table 1 below.

	Advantages	Disadvantages
Hand pumps	<ul style="list-style-type: none"> <li>local manufacture is possible</li> <li>easy to maintain</li> <li>low capital cost</li> <li>no fuel costs</li> </ul>	<ul style="list-style-type: none"> <li>loss of human productivity</li> <li>often an inefficient use of boreholes</li> <li>only low flow rates are achievable</li> </ul>
Animal driven pumps	<ul style="list-style-type: none"> <li>more powerful than humans</li> <li>lower wages than human power</li> <li>dung may be used for cooking fuel</li> </ul>	<ul style="list-style-type: none"> <li>animals require feeding all year round</li> <li>often diverted to other activities at crucial irrigation periods</li> </ul>
Hydraulic pumps (e.g. rams)	<ul style="list-style-type: none"> <li>unattended operation</li> <li>easy to maintain</li> <li>low cost</li> <li>long life</li> <li>high reliability</li> </ul>	<ul style="list-style-type: none"> <li>require specific site conditions</li> <li>low output</li> </ul>
Wind pumps	<ul style="list-style-type: none"> <li>unattended operation</li> <li>easy maintenance</li> <li>long life</li> <li>suited to local manufacture</li> <li>no fuel requirements</li> </ul>	<ul style="list-style-type: none"> <li>water storage is required for low wind periods</li> <li>high system design and project planning needs</li> <li>not easy to install</li> </ul>
Solar PV	<ul style="list-style-type: none"> <li>unattended operation</li> <li>low maintenance</li> <li>easy installation</li> <li>long life</li> </ul>	<ul style="list-style-type: none"> <li>high capital costs</li> <li>water storage is required for cloudy periods</li> <li>repairs often require skilled technicians</li> </ul>
Diesel and gasoline pumps	<ul style="list-style-type: none"> <li>quick and easy to install</li> <li>low capital costs</li> <li>widely used</li> <li>can be portable</li> </ul>	<ul style="list-style-type: none"> <li>fuel supplies erratic and expensive</li> <li>high maintenance costs</li> <li>short life expectancy</li> <li>noise and fume pollution</li> </ul>

Table 1: Comparison of pumping techniques

### Applications

Solar pumps are used principally for three applications:

- village water supply
- livestock watering
- irrigation

A solar pump for village water supply is shown schematically in Figure 1. With village water supply, a constant water demand throughout the year occurs, although there is need to store water for periods of low insolation (low solar radiation). Typically in Sahelian Africa the storage would be 3-5 days of water demand. In environments where rainy seasons occur, rainwater harvesting can offset the reduced output of the solar pump during this period. The majority of the 6000 or more solar pumping systems installed to date are for village water supply or livestock watering.

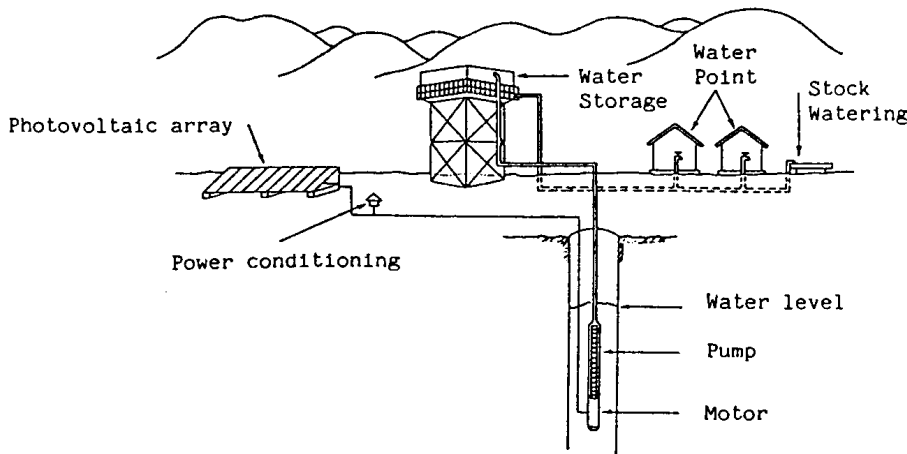

Figure 1: Village Water Supply

A solar irrigation system (Figure 2) needs to take account of the fact that demand for irrigation water will vary throughout the year. Peak demand during the irrigation seasons is often more than twice the average demand. This means that solar pumps for irrigation are under-utilised for most of the year. Attention should be paid to the system of water distribution and application to the crops. The system should minimise water losses, without imposing significant additional head on the pumping system and be of low cost.

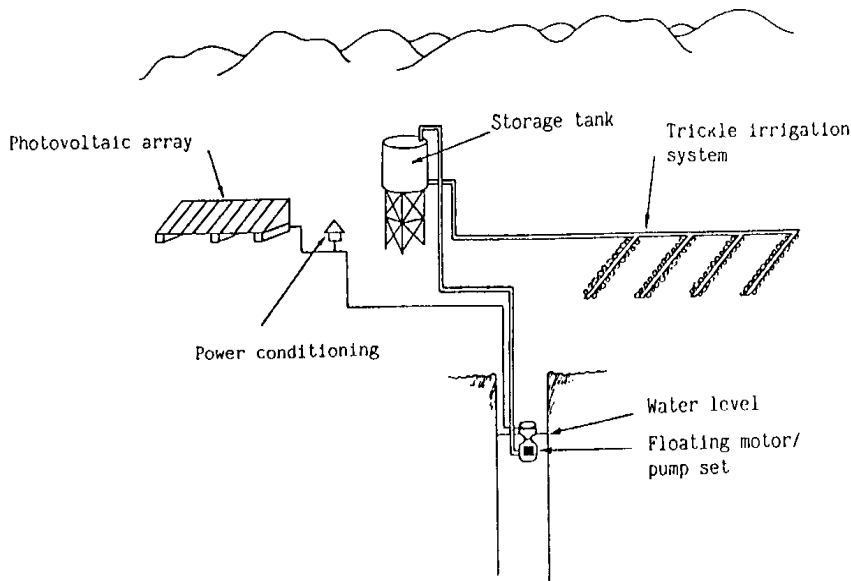

Figure 2: Solar Irrigation System

The suitability of major irrigation systems for use with solar pumps is shown in Table 2.

Distribution method	Typical application efficiency	Typical head	Suitability for use With solar pumps
Open Channels	50-60%	0.5-1m	Yes
Sprinkler	70%	10-20m	No
Trickle/drip	85%	1-2m	Yes
Flood	40-50%	0.5m	No

Table 2: Suitability of major irrigation methods for use with solar pumps

**The technology**

Systems are broadly configured into 5 types as described below:

technical brief

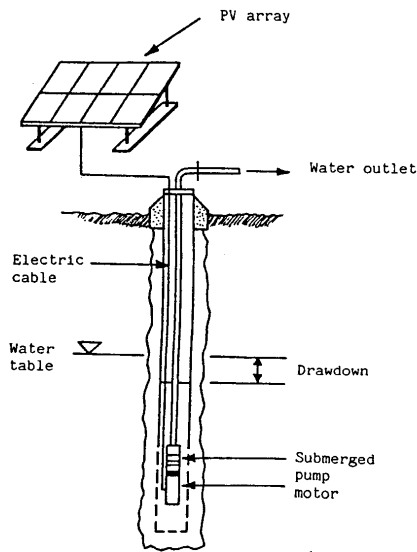

Figure 3

**Submerged multistage centrifugal motor pumpset - Figure 3**

This type is probably the most common type of solar pump used for village water supply. The advantages of this configuration are that it is easy to install, often with lay-flat flexible pipework and the motor pumpset is submerged away from potential damage.

Either ac or dc motors can be incorporated into the pumpset although an inverter would be needed for ac systems. If a brushed dc motor is used then the equipment will need to be pulled up from the well (approximately every 2 years) to replace brushes. If brushless dc motors are incorporated then electronic commutation will be required. The most commonly employed system consists of an ac pump and inverter with a photovoltaic array of less than 1500Wp.

**Submerged pump with surface mounted motor - Figure 4**

This configuration was widely installed with turbine pumps in the Sahelian West Africa during the 1970s. It gives easy access to the motor for brush changing and other maintenance.

The low efficiency from power losses in the shaft bearings and the high cost of installation has been disadvantages. In general this configuration is largely being replaced by the submersible motor and pumpset.

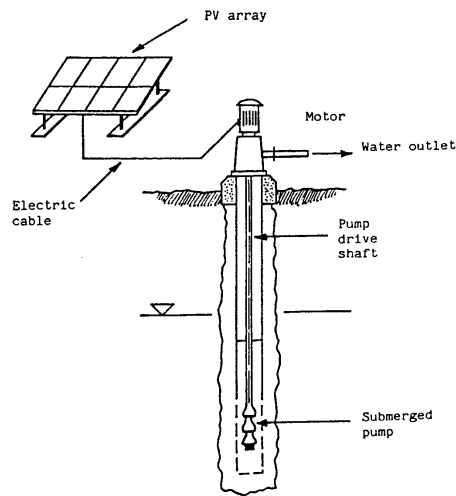

Figure 4

technical brief

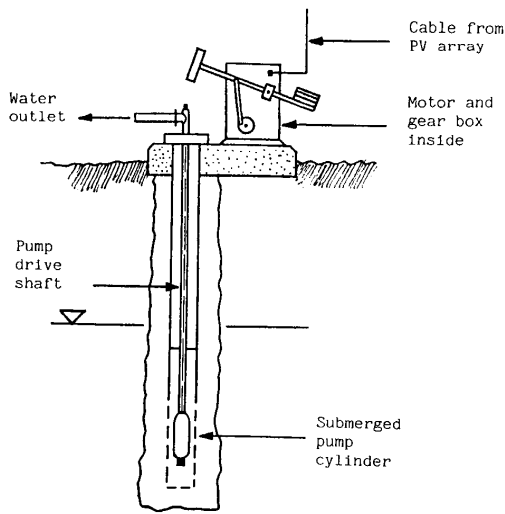

Figure 5

components of the solar pump are often heavy and robust, and power controllers for impedance matching often used.

**Floating motor pump sets - Figure 6**

The versatility of the floating unit set, makes it ideal for irrigation pumping for canals and open wells. The pumpset is easily portable and there is a negligible chance of the pump running dry.

Most of these types use a single stage submersed centrifugal pump. The most common type utilises a brushless (electronically commutated) dc motor. Often the solar array support incorporates a handle or 'wheel barrow' type trolley to enable transportation.

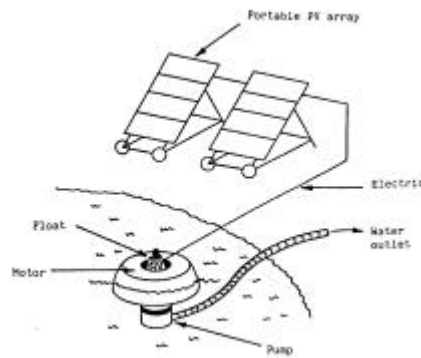

Figure 6

**Surface suction pumpsets - Figure 7**

This type of pumpset is not recommended except where an operator will always be in attendance. Although the use of primary chambers and non-return valves can prevent loss of prime, in practice self-start and priming problems are experienced. It is impractical to have suction heads of more than 8 metres.

**Performance**

The performance of some commercially available products is shown in Figure 8. It can be seen that solar pumps are

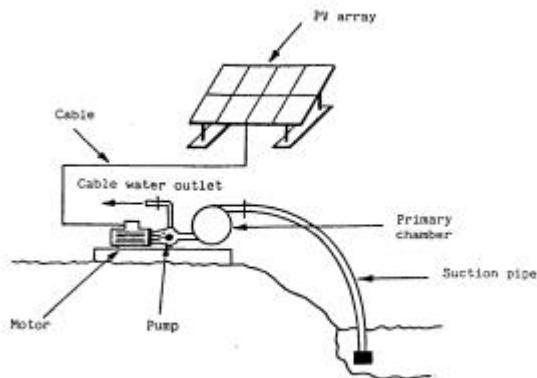

Figure 7

technical brief

available to pump from anywhere in the range of up to 200m head and with outputs of up to 250m<sup>3</sup>/day.

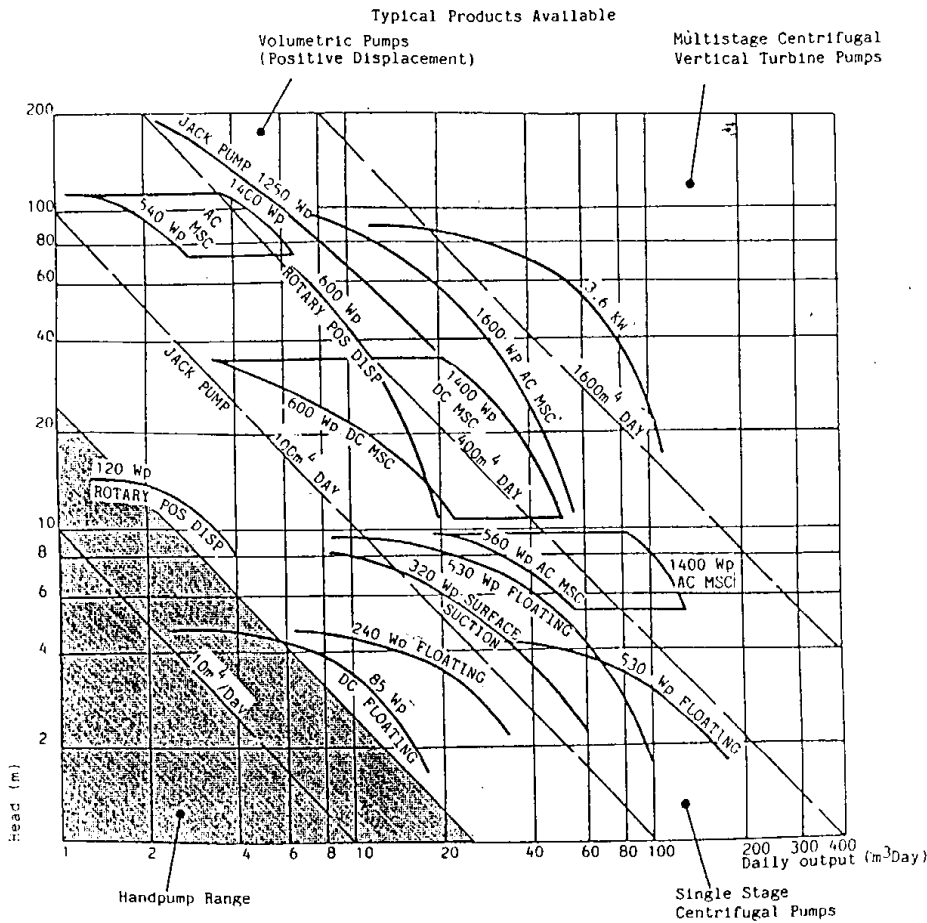

Figure 8

Solar pumping technology continues to improve. In the early 1980s the typical solar energy to hydraulic (pumped water) energy efficiency was around 2% with the photovoltaic array being 6-8% efficient and the motor pumpset typically 25% efficient. Today, an efficient solar pump has an average daily solar energy to hydraulic efficiency of more than 4%. Photovoltaic modules of the monocrystalline type now have efficiencies in excess of 12% and more efficient motor and pumpsets are available. A good sub-system (that is the motor, pump and any power conditioning) should have an average daily energy throughput efficiency of 30-40%.

**Costs**

A photovoltaic pumping system to pump 25m<sup>3</sup>/day through 20m head requires a solar array of approximately 800Wp in the Sahelian regions. Such a pump would cost approximately \$6,000 FOB. Other example costs are shown in Table 3.

A range of prices is to be expected, since the total system comprises the cost of modules, pump, motor, pipework, wiring, control system, array support structure and packaging. Systems with larger array sizes generally have a lower cost/Wp. The cost of the motor pumpset varies according to application and duties; a low lift suction pump may cost less than \$800 whereas a submersible borehole pumpset costs \$1500 or more.

technical brief

Motor pump/ Configuration	Output (m <sup>3</sup> .day) @ 5kWhm/cu.m/ day insolation	Head (m)	Solar Array (Wp)	System Price US\$ FOB
Submerged borehole motor pump	40	20	1200	7000-8000
	25	20	800	6000-7000
Surface motor/ submerged pump	60	7	840	5000-6000
Reciprocating positive displacement pump	6	100	1200	7500-9000
Floating motor/pumpset	100	3	530	4000
	10	3	85	2000
Surface suction pump	40	4	350	3000

Table 3 - Photovoltaic pumping system specifications

**Procurement**

**Assessing requirements**

The output of a solar pumping system is very dependent on good system design derived from accurate site and demand data. It is therefore essential that accurate assumptions are made regarding water demand/pattern of use and water availability including well yield and expected drawdown.

Domestic water use per capita tends to vary greatly depending on availability. The long-term aim is to provide people with water in sufficient quantities to meet all requirements for drinking, washing and sanitation. Present short-term goals aim for a per capita provision of 40 litres per day, thus a village of 500 people has a requirement of 20 cubic metres per day. Most villages have a need for combined domestic and livestock watering.

Irrigation requirements depend upon crop water requirements, effective groundwater contributions and efficiency of the distribution and field application system.

Irrigation requirements can be determined by consultation with local experts and agronomists or by reference to FAO document 'Cropwater requirements' (J Dorrenbos, WO Pruitt - FAO, Rome, Italy - 1977).

**Assessing water availability**

Several water source parameters need to be taken into account and where possible measured. These are the depth of the water source below ground level, the height of the storage tank or water outlet point above ground level and seasonal variations in water level. The drawdown or drop in water level after pumping has commenced also needs to be considered for well and borehole supplies. This will depend on the ratio between pumping rate and the rate of refill of the water source.

The pattern of water use should also be considered in relation to system design and storage requirements. Water supply systems should include sufficient covered water storage to provide for daily water requirements and short periods of cloudy weather. Generally, two to five days water demand is stored.

technical brief

## Sizing solar pumps

The hydraulic energy required (kWh/day)

$$= \text{volume required (m}^3\text{/day)} \times \text{head (m)} \times \text{water density} \times \text{gravity} / (3.6 \times 10^6)$$

$$= 0.002725 \times \text{volume (m}^3\text{/day)} \times \text{head (m)}$$

The solar array power required (kWp) =

$$\frac{\text{Hydraulic energy required (kWh/day)}}{\text{Av. daily solar irradiation (kWh/m}^2\text{/day} \times F \times E)}$$

where F = array mismatch factor = 0.85 on average  
and E = daily subsystem efficiency = 0.25 - 0.40 typically

## Economics

In general photovoltaic pumps are economic compared to diesel pumps up to approximately 3kWp for village water supply and to around 1kWp for irrigation.

## References

Roy Barlow, Bernard McNelis and Anthony Derrick: Solar Pumping. An introduction and update on the technology, performance, costs and economics.  
IT Publications, 1993

Peter Fraenkel: Water Pumping Devices. A handbook for users and choosers.  
ITDG Publishing, 1997.

Jeff Kenna and Bill Gillett: Solar Water Pumping. A handbook.  
IT Publications, 1985.

U.R.S. Rentch: Solar Photovoltaics for Irrigation Water Pumping.  
SKAT, St. Gallen, 1982.

Groundwater: Waterlines, Vol.20, No.2, October 2001, ITDG Publishing

## Useful addresses

The International Solar Energy Society (ISES)  
International Headquarters  
Villa Tannheim, Wiesentalstr. 50,  
79115 Freiburg, Germany.  
Tel.: +49 - 761 - 45906-0  
Fax: +49 - 761 - 45906-99  
Email: [hq@ises.org](mailto:hq@ises.org)  
Web: <http://www.ises.org/>

International Centre for Application of Solar  
Energy (CASE)  
Level 8, 220 St Georges Terrace,  
Perth WA 6000, Australia.  
Phone: +61 (08) 9321 7600  
Fax: +61 (08) 9321 7497  
Email: [info@case.gov.au](mailto:info@case.gov.au)  
Web: [www.case.gov.au](http://www.case.gov.au)

HTN/SKAT  
Vadianstrasse 42, CH-9000 St. Gallen,  
Switzerland.  
Tel: +41 71 228 54 54  
Fax: +41 71 228 54 55  
Email: [info@skat.ch](mailto:info@skat.ch)  
Web: <http://www.skat.ch/htn>

Lifewater International  
2840 Main Street, Morro Bay, CA 93442  
Mailing address: PO Box 3131, San Luis  
Obispo, CA 93403, USA  
Tel: +1 805-772-0600, +1 888-543-3426  
Fax: +1 805-772-0606  
Email: [info@lifewater.org](mailto:info@lifewater.org)  
Web: <http://www.lifewater.org/>

### Suppliers of photovoltaic pumps

Note: This is a selective list of suppliers and does not imply ITDG endorsement.

AEG,  
Industriestrasse 29, D-2000 Wedel, Holstein,  
Germany.  
Tel: +49 41 03 7021  
Fax: +49 41 03 84 474

A.Y. MacDonald Manufacturing Company,  
4800 Chavenelle Road, Dubuque, IA 5200,  
USA.  
Tel: +1 319 583 7311  
Fax: +1 319 588 0720  
Web: [www.aymcdonald.com](http://www.aymcdonald.com)

BP Solar,  
P.O. Box 191, Chertsey Road,  
Sunbury-on-Thames TW16 7XA, U.K.  
Tel: +44 1932 779543  
Fax: +44 1932 762686  
Web: [www.bpsolar.com](http://www.bpsolar.com)

Grundfos International A/S,  
Poul Due Jensens Vej 7, Bjerroingbo, DK-8850  
Denmark  
Tel: +45 86 68 1400  
Fax: +45 86 68 0468  
Web: [www.grundfos.com](http://www.grundfos.com)

Italsolar,  
Via A D'Andrea, 6 Nettuno 00048, Italy  
Tel: +39 6 985 0246  
Fax: +39 6 985 0269

Mono Pumps Ltd.,  
P.O. Box 14, Martin Street, Audenshaw,  
Manchester M34 5DQ, U.K.  
Tel: +44 (0)161 339 9000  
Fax: +44 (0)161 344 0727  
Web: [www.mono-pumps.com](http://www.mono-pumps.com)

Siemens Solar GmbH,  
Frankfurter Ring 152, 80807 Munich, Germany  
Tel: +49 89 636 59158  
Fax: +49 89 636 59173  
Web: [www.solarpv.com](http://www.solarpv.com)

Total Energie,  
7 Chemin du Plateau, 69570 Dardilly, France  
Tel: +33 4 7252 1320  
Fax: +33 4 7864 9100  
Web: [www.total-energie.com](http://www.total-energie.com)

technical brief