

McGill University
Faculty of Engineering
BRACE RESEARCH INSTITUTE

How To Construct A CHEAP WIND MACHINE FOR PUMPING WATER

Do-it-Yourself Leaflet No. L-5

February 1965

Revised February 1973

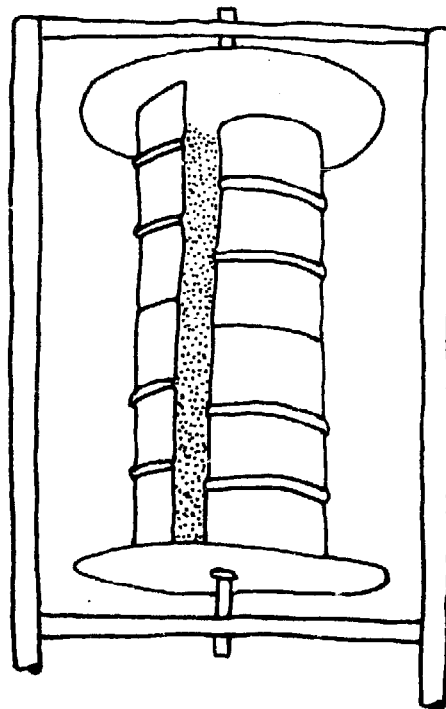

BRACE RESEARCH INSTITUTE
MacDONALD COLLEGE OF MCGILL UNIVERSITY
STE ANNE DE BELEVUE 800
QUEBEC, CANADA

How To Construct A CHEAP WIND MACHINE FOR PUMPING WATER

Instructions for building a Savonius Rotor for Water Pumping

Introduction

The Savonius Rotor is a vertical-shaft wind-machine, developed by the Finish engineer, S. J. Savonius, during the years 1925—28.

A test program was carried out on this type of machine by the Brace Research Institute to find out its potentialities for low cost water pumping.

From the tests the following conclusions can be drawn: The Savonius Rotor, although not as efficient as a windmill of comparable size, lends itself to water pumping for irrigation in underdeveloped areas due to its low initial cost, simplicity of materials and construction, and low maintenance cost.

It will successfully operate in areas where the wind speeds are in the region of 8 to 12 mph. and above, and the water level is not more than 10 to 15 ft. below ground. The rotor, drive and pump are eminently suitable for home construction by the handyman with but a few tools and access to a welding set. It can be made from a variety of materials at low cost since no critical machining is necessary.

The only important points to be observed in erecting such a machine is the proper choice of the site and careful assessment of the average wind-speeds. From this information the proper pump size and stroke can be chosen from the graphs at the back of this pamphlet. It will also be necessary to provide some sort of water storage into which water can be pumped at good wind-speeds and later used for irrigation when needed. The bigger the storage capacity the more flexible the system becomes.

The rotor described here is the one used for all the tests carried out at the Brace Research Institute and was built from locally (Barbados) available materials in a small workshop with unskilled labor at very low cost.

The whole pumping system comprises 3 units: The rotor, the drive and the pump.

Each unit will be dealt with separately. These instructions apply to the type built at Brace, but it is left to the builder's ingenuity to substitute other materials or processes of construction to suit local conditions. The only important measurements to be adhered to are the proportions of the rotor itself, as shown in Fig. 1.

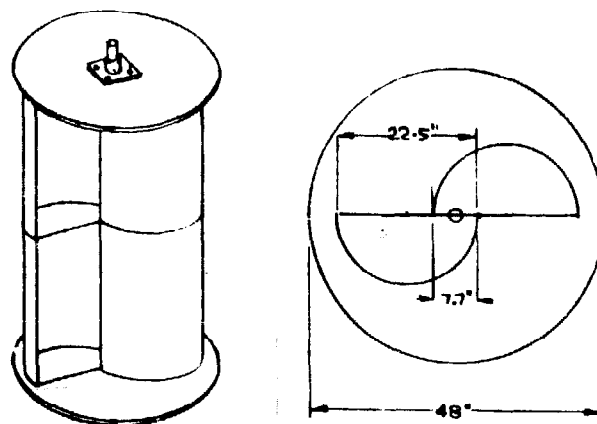

Fig. 1.

1. The Rotor

It consists of two 45 gallon oil drums, bisected lengthwise and welded together to form two troughs. (Fig. 2). These two troughs are mounted between two end plates, made from $\frac{1}{2}$ "

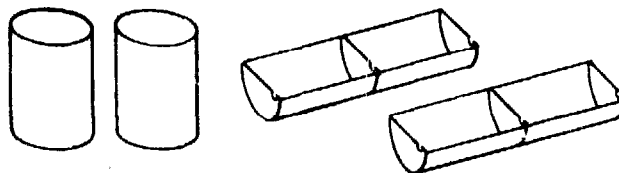

Fig. 2.

plywood, 48" diameter. They can both be cut from one single sheet of standard plywood, which measures 48 ins. by 96 ins. The dimensions for mounting the drum halves are given in Fig. 1. The ends of the oil drums are simply bolted to the wooden disks with $\frac{3}{8}$ in. stove bolts, washers and nuts. The shaft through the center of the rotor is $1\frac{1}{4}$ in. ID water pipe, which should extend about 6 ins. beyond either end of the end plates. To secure the shaft to the end plates two flanged collars are used, as shown in Fig. 3. They should be a snug fit on the outside of the shaft. They are bolted to the plywood with 4 bolts, and after inserting the shaft, are drilled and secured to it with a $\frac{3}{4}$ in. bolt, spring washer and nut. To support

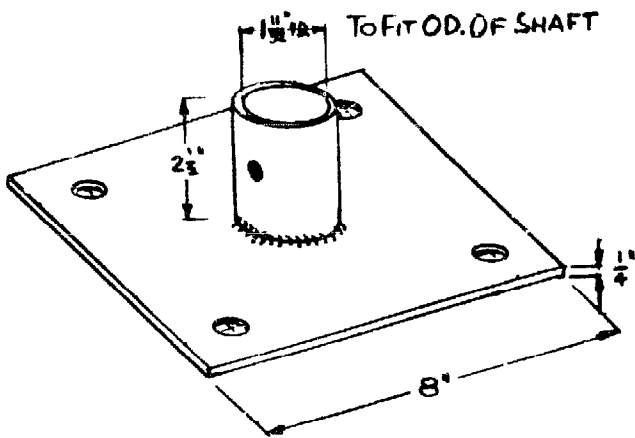

Fig. 3.

the rotor shaft in the frame, two self-aligning ball-bearings are required, the ones used in the prototype being "Fafnir L.C.J., 1 in. Bore" but any equivalent flange-type bearing can be used.

TOP SUPPORT

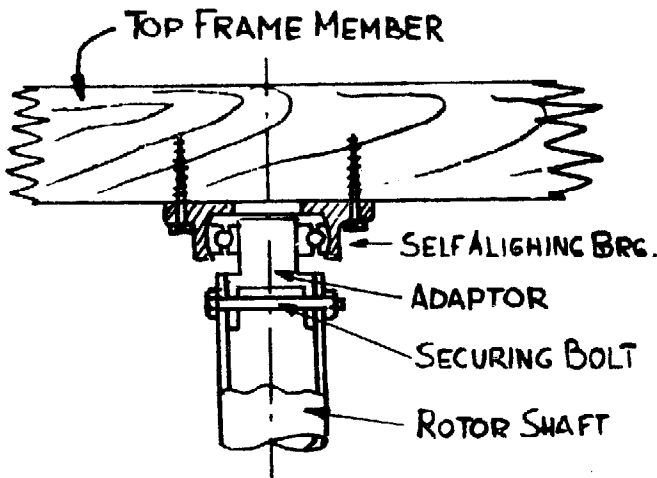
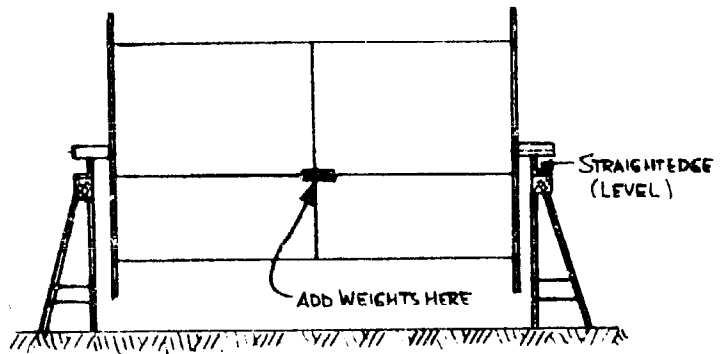

Fig. 4.

Two adaptors, as shown in Fig. 4, have to be made to fit the two ends of the shaft to the bearings. The lower adaptor must be long enough to take the eccentric at its lower end, after passing through a clearance hole in the lower frame member.

Before mounting the rotor in the frame it must be carefully balanced to avoid vibrations at high speeds. This is easily done by placing the assembled rotor horizontally on two level straight edges and adding weights to the circumference in the center of the rotor, until perfect balance is achieved. (See Fig. 5).



METHOD FOR BALANCING ROTOR.

Fig. 5.

BOTTOM SUPPORT

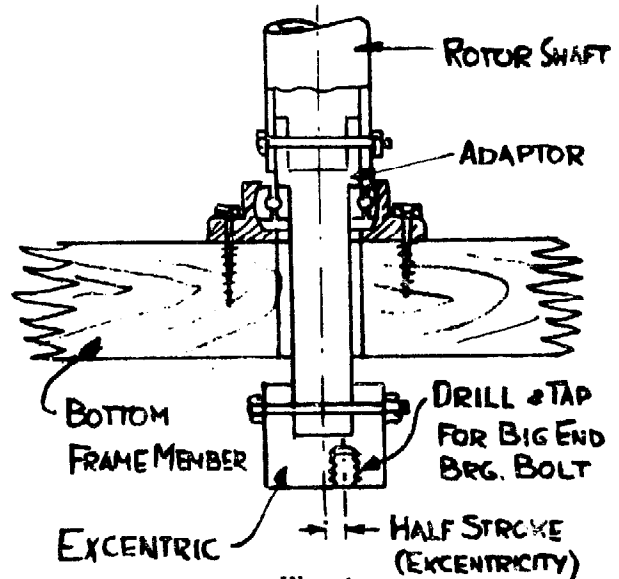
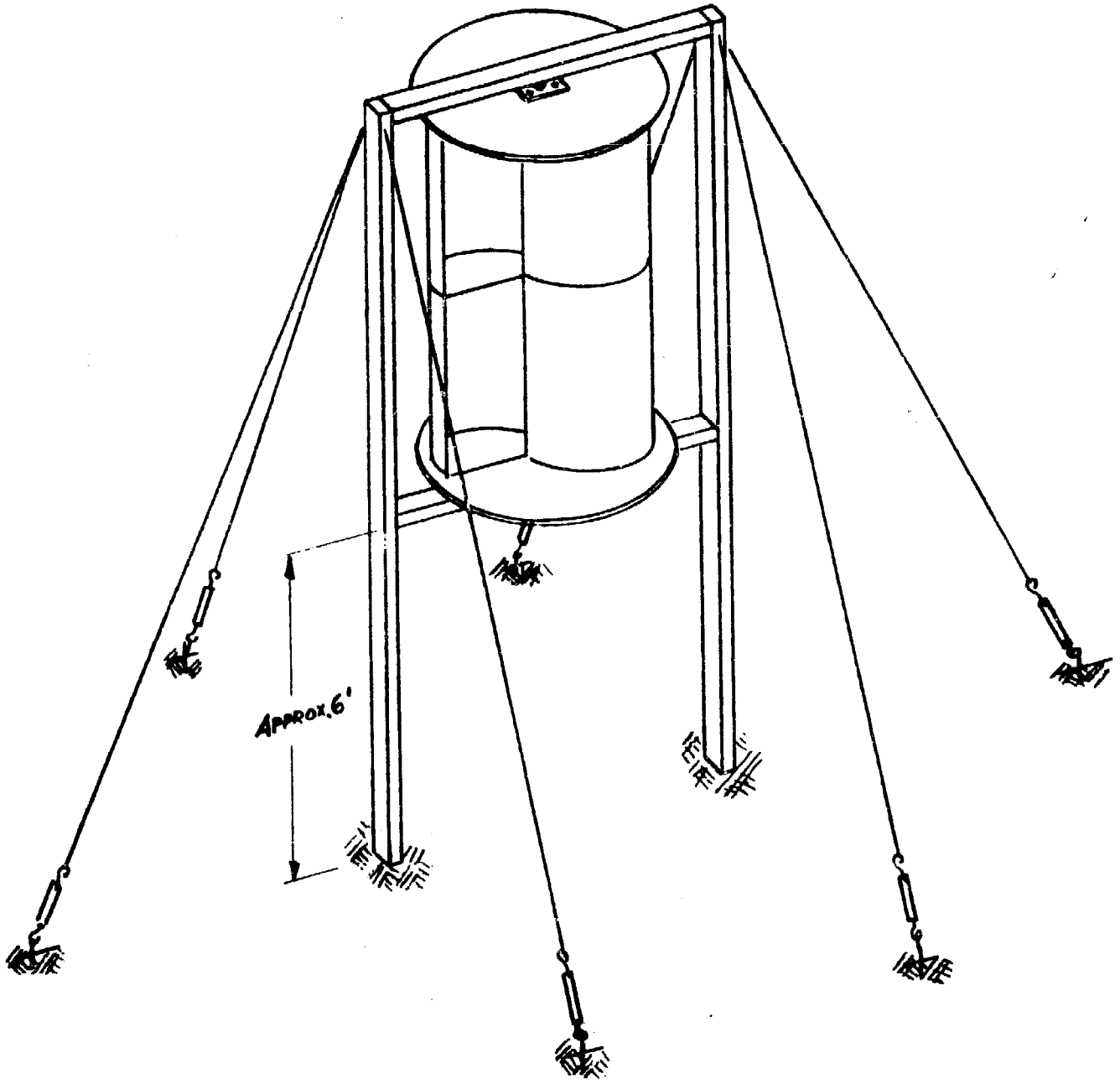

Fig. 4.

THE FRAME

The frame consists of four pieces of 4 in. by 2 in. timber, as shown in Fig. 6. The joints should be securely bolted with gusset plates, to make it as stiff as possible. It must be steadied with wire guys, securely anchored to the ground and tensioned by turnbuckles. The lower cross member should be about 6 ft. above the ground, but can be more if practicable.



FRAME & GUY WIRES

Fig. 6.

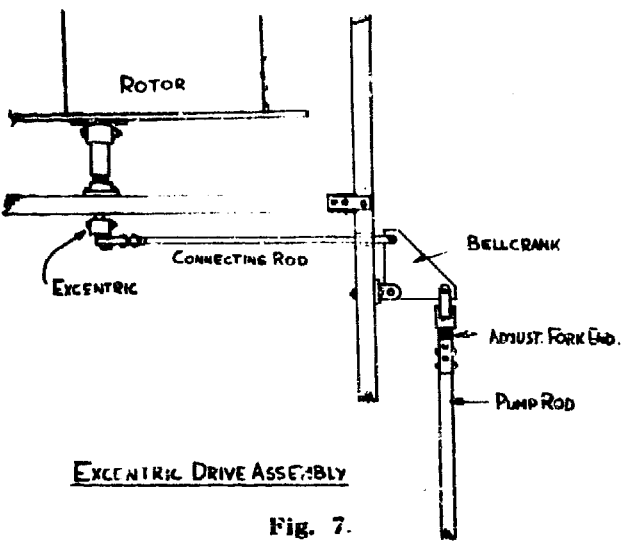
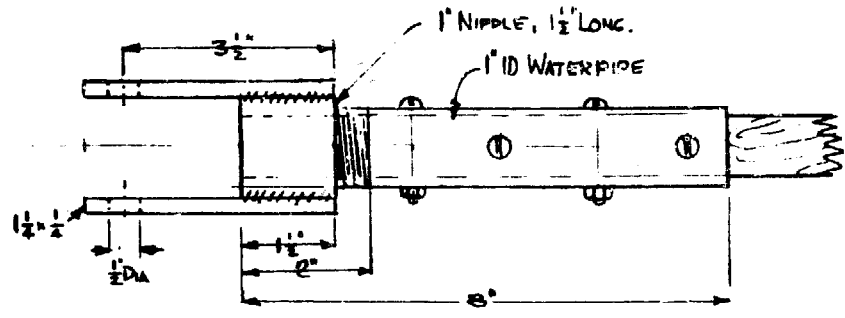

Fig. 7.

2. The Drive

It consists of the eccentric, horizontal connecting rod, bell crank and vertical pump rod. See Fig. 7.

The eccentric is a piece of steel, bored to fit the end of the lower adaptor and secured to it by a through bolt. The face is drilled and lapped to receive a bolt which must be a good fit in the bore of the ball bearing, forming the big end. The eccentricity is $7/32$ ins. which gives a stroke of $7/16$ in. The big end of the connecting rod is a ball bearing, $1/2$ in. bore, which is held in a split fitting attached to the rod. The connecting rod of a motorcycle or small car engine will do nicely for this purpose. Cut the shank off and weld a piece of 1 in. ID tubing to it, about 6 ins. long to receive the wooden connecting rod. (Fig. 8C).



a. ADJUSTABLE PUMPROD FORKEND

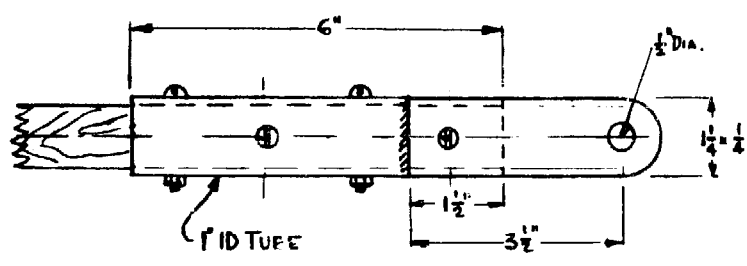

b. CONNECTING ROD FORK END.

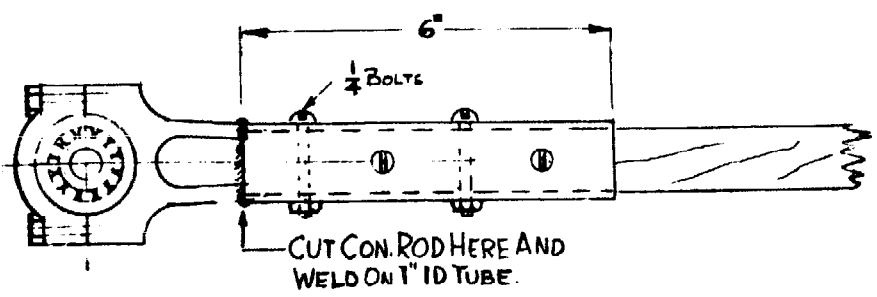

c. CONNECTING ROD BIG END

Fig. 8

Since the pump is a single acting diaphragm pump, the two actuating rods are only in tension, and are therefore made of wood, 1 in. square. With the small eccentricity and the flexibility of the wood it is not necessary to have a universal joint at the bell crank end. The wooden connecting rod carries a fork on its small end, with a good fitting pin of $\frac{1}{2}$ in. dia. through a hole in the upper arm of the bell crank. The pump rod is a similar piece of 1 in. square wood with an adjustable fork end on top. Refer to Figs. 8A and 8B, which are self-explanatory.

The bell crank is made from a piece of $\frac{1}{4}$ in. steel plate, cut as shown in Fig. 9. The holes are reinforced with welded bosses as shown and drilled after welding. If possible these bearing holes should be bushed with a bronze bush, this will increase the life of the pin and prevent the system from developing

backlash. There should also be an oil hole for lubrication. The overall width of the bushes must be a close fit in the fork to prevent any side play.

3. The Pump

The pump selected for this application is a single acting diaphragm pump. This design has been chosen because it is simple to build, with minimum machining required. It is practically maintenance free and it is cheap. All pipe connections are standard 1 inch water-pipe nipples and elbows. The valves can be any commercially available type of non-return valve.

The pump itself is mounted just below water level (fully submerged) so that there is no compression in the rod on the suction stroke. A screen should be fitted on the intake valve to prevent foreign matter entering the pump. The diaphragm is made from a piece of inner tube, $\frac{3}{32}$ to $\frac{1}{8}$ in. thick. The flange should be at

BELL CRANK

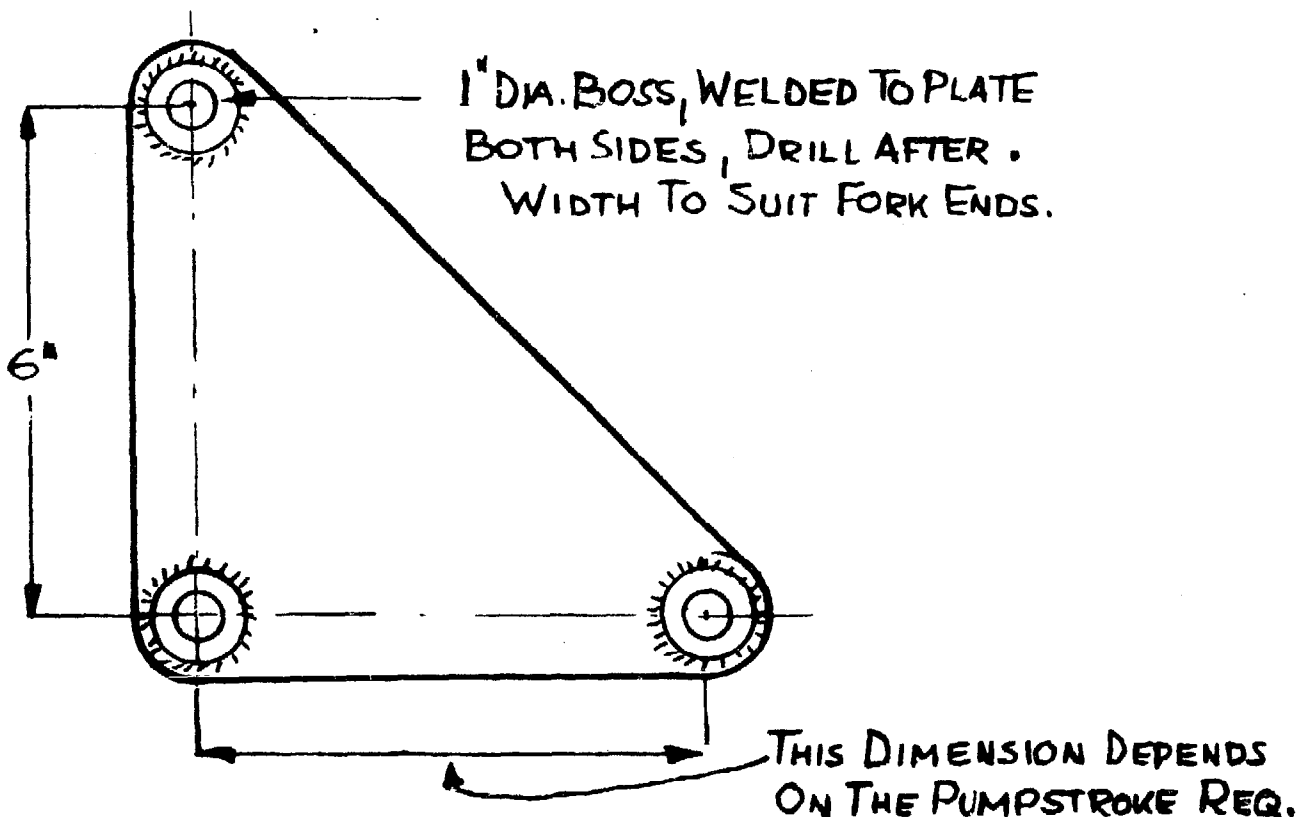

Fig 9.

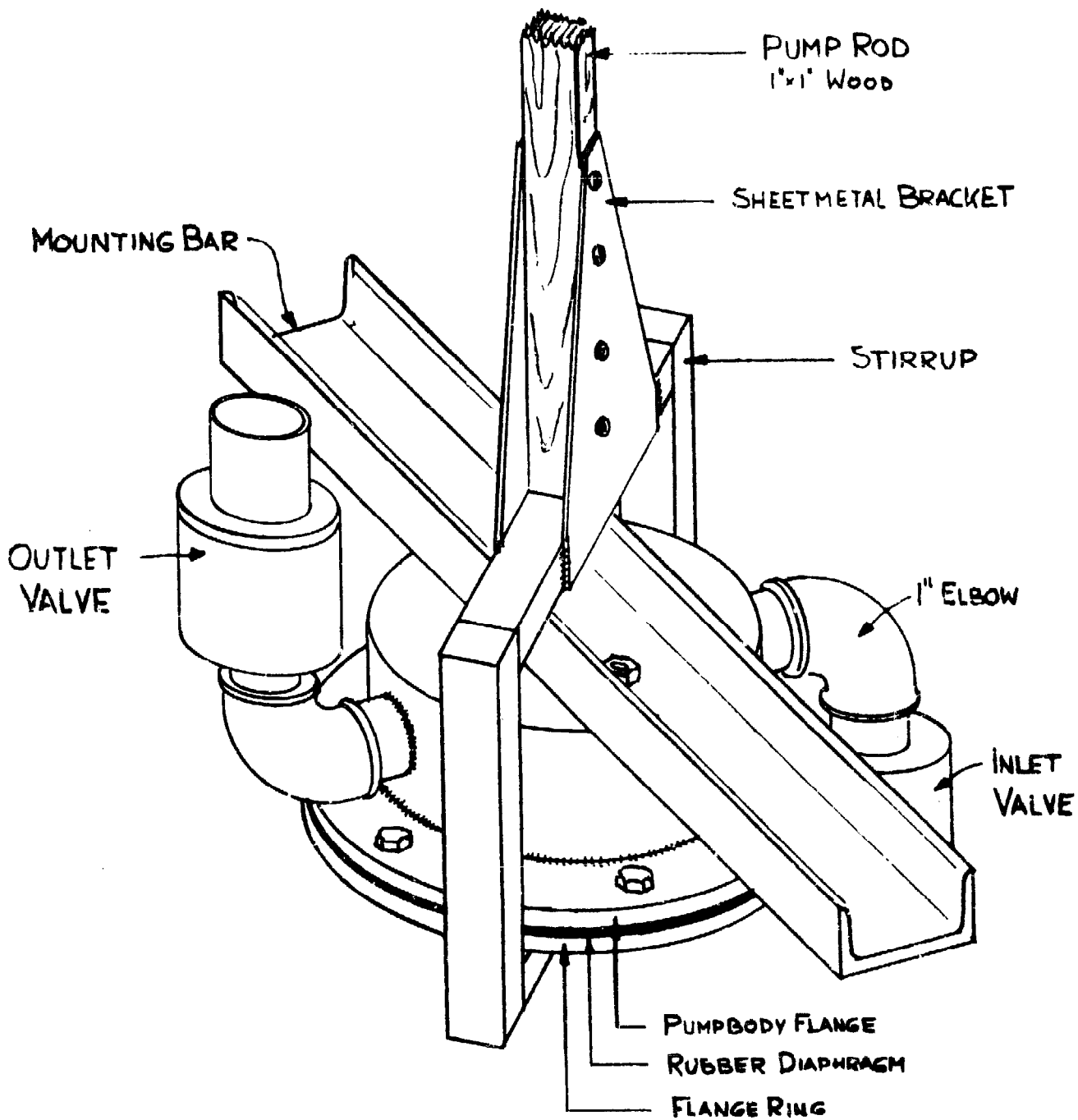

Fig. 10

least 1-1/4 in. wide and have 8 bolts around the circumference, to ensure a good seal.

As can be seen in Figs. 10 and 11, the pump is inverted, the diaphragm being operated through a stirrup attached to the pump rod. This gives the pump greater flexibility and is simpler than leading the rod through the pump

chamber. The dimensions of the pump are not too critical once the diameter and stroke have been determined. The stirrup must be dimensioned so that it provides a definite stop on the up and down stroke. This will prevent damage to the diaphragm during handling and installation.

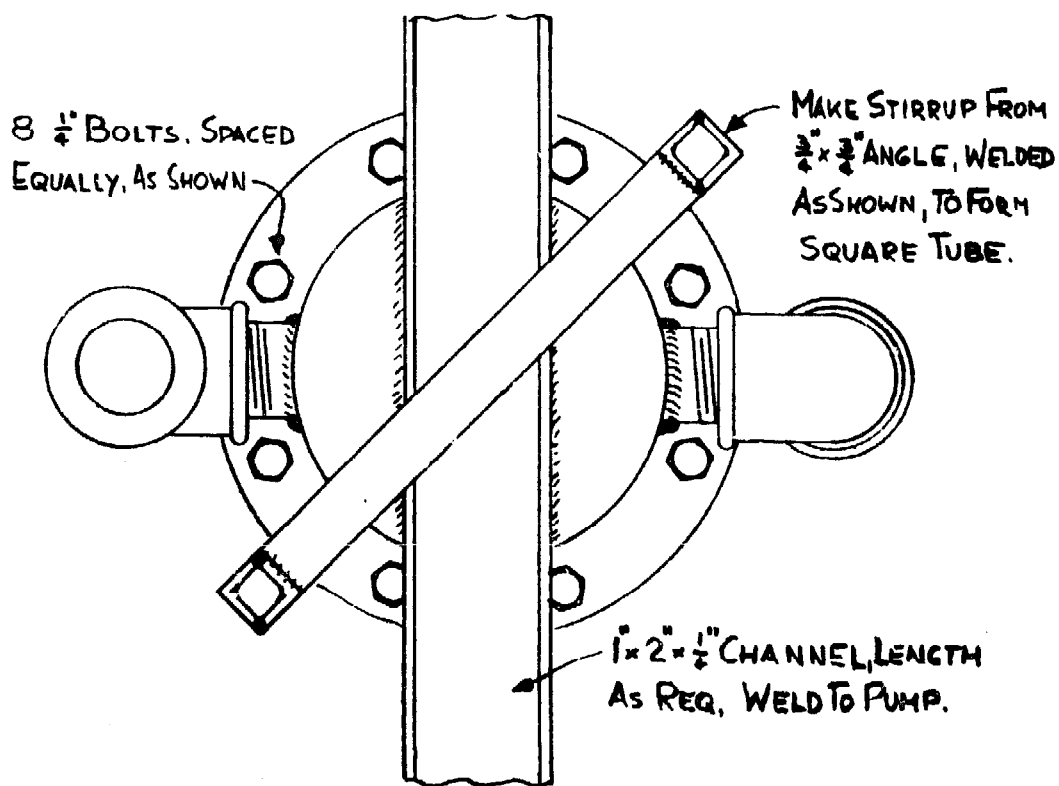
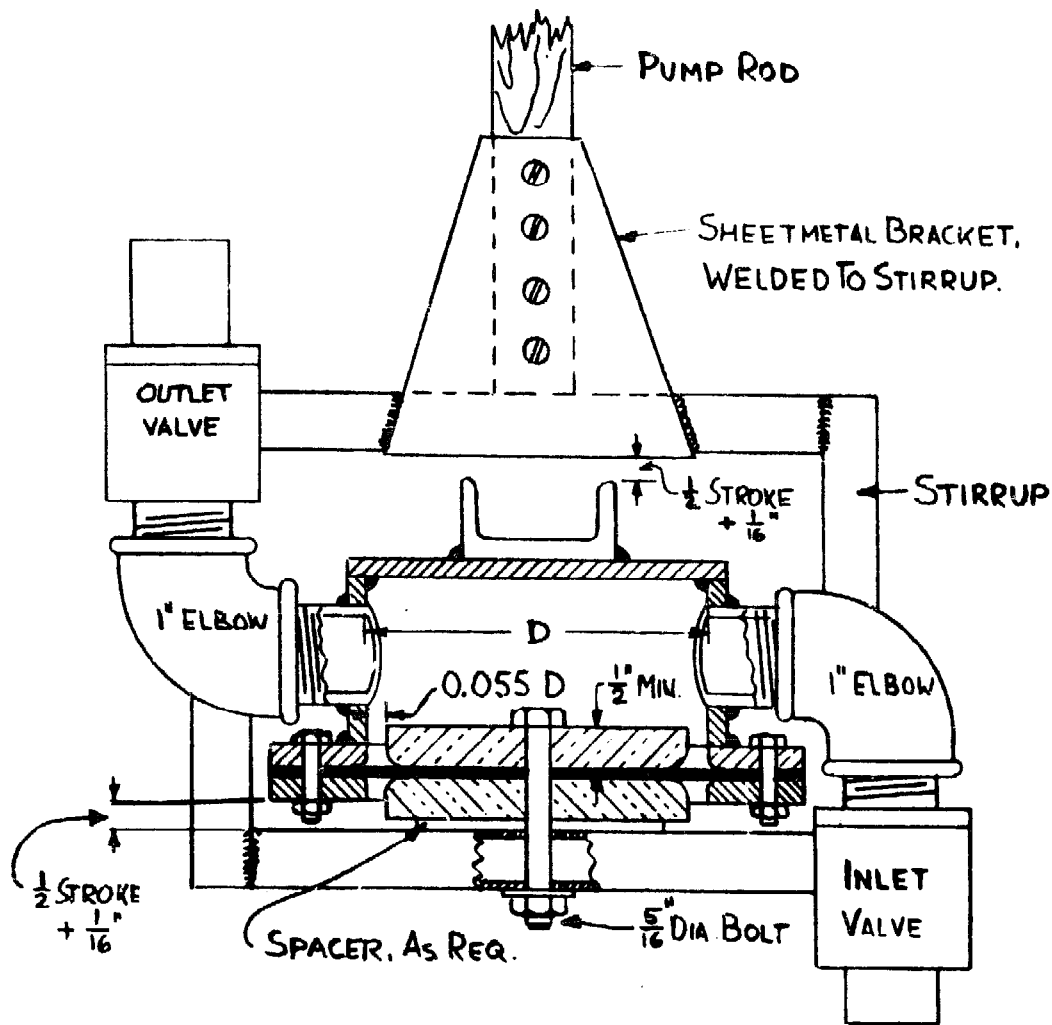

Fig. 11.

The main body of the pump consists of a piece of pipe or welded ring, closed at one end and having a welded flange on the other. A flange ring provides the clamping of the rubber diaphragm. See Fig. 11. Two 1 inch water-pipe nipples are welded on each side for the inlet and outlet valves. The two discs supporting the rubber diaphragm were made from "Tufnol", a hard, resin impregnated fabric, but any similar hard material can be used, even hardwood will do, if nothing else can be procured. The clearance between discs and pump-body is $0.055D$ and the inside corners of the discs must be well rounded to prevent cutting the rubber on the up and down stroke. This is very important. When assembling the pump, sealing-compound is applied to the rubber between the discs and the flanges to assure a good seal. The mounting bar on top of the housing must be very stiff and can be either welded or bolted to the top plate. If bolts are used they must be a good fit and should have copper washers to insure against leaks. It is most important when mounting the pump in the well, to secure the mounting bar very firmly either by concreting, or bolting to a couple of cross-timbers in the well. The tension forces in the pump-rod are in the region of 200 lbs. and at high revolutions this hammering will soon shake loose a weak mounting. The pump-rod should be left longer than the required length before mounting the pump in the well. After the pump has been installed and the bell crank is mounted on the frame, the bell crank is brought to its neutral position and the adjustable fork end of the pump-rod to halfway on the thread. The rod is now cut so that it will fit fully into the tube of the fork, drilled and secured with 4 bolts, as shown in Fig. 8A. Now the pump-rod is pulled up against the stop, the eccentric turned to full stroke and the fork adjusted so that the pin goes freely through the hole in the bell crank. Now turn the fork another one and a half turns

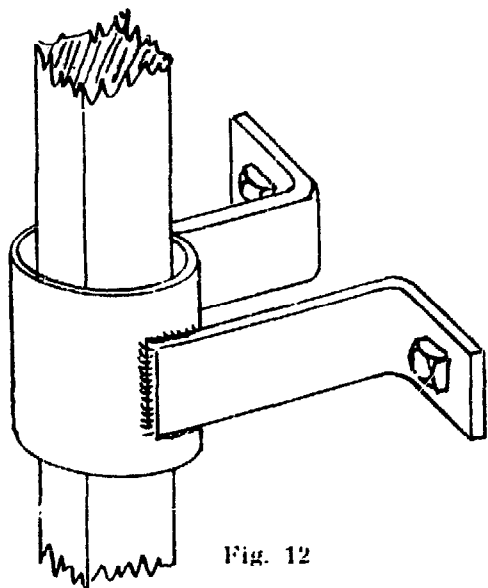

Fig. 12

to lengthen the rod, insert the pin and secure it. This will prevent the pump hitting the top at its full stroke.

This adjustment must be carried out very carefully, otherwise the pump will be wrecked during the first moment of operation. It might also be necessary to install one or two pump-rod guides if the rod is longer than 10 ft. They should be fitted after the whole system is fixed in place. (See Fig. 12). They must not touch the pump-rod when it is stationary.

Selecting the Diameter & Stroke of Pump

On graph No. 1, select the head of water to be pumped. This is the vertical distance between the water level in the well, and the outlet in the reservoir. The graph is already corrected for the dynamic head, which includes the friction in the pipe and the valves. From the head of water on the left scale draw a horizontal line until it intersects the appropriate wind speed curve and draw a vertical line through this point. This will intersect one of the four straight lines marked: Pump 1, 2, 3, and 4. Each is for one pump, of a given diameter and gives on the right hand scale the proper stroke for this particular pump and head combination.

Example: (Follow dotted line on graph)

Head 15 ft. windspeed 10 mph.

Draw horizontal line at 15 ft. head.

At intersection with 10 mph. curve draw vertical line.

It intersects straight line of pump 2

From this point draw horizontal line to the right hand stroke-scale.

This gives a stroke of 0.56 in.

The pump has to operate at this stroke to give the best efficiency of the rotor. To obtain this stroke from the bell crank, proceed as follows: The ratios of stroke and distance from pivot are equal.

Therefore: $0.4375 : 6 = 0.56 : x$

$$x = \frac{6 \times 0.56}{0.4375} = 7.7$$

The horizontal arm of the bell crank will have to be 7.7 ins long to give a pump stroke of 0.56 in. Fig 9.

The bottom scale of Graph No. 1 gives the actual volume in cubic ins. per stroke pumped at various wind speeds.

This makes it possible to determine the size and stroke of any other available pump, such as a piston pump.

Find the head to be pumped and the wind speed as before, draw a vertical line from this point to the bottom scale and read the volume per stroke. Divide this volume by the piston area and this will be the stroke required.

If, for example, a piston pump of 2 in. diameter were available the head is again 15 ft. and the wind speed 10 mph., continue the

**GRAPHIC DIAGRAM FOR
SELECTION OF DIA. AND STROKE**

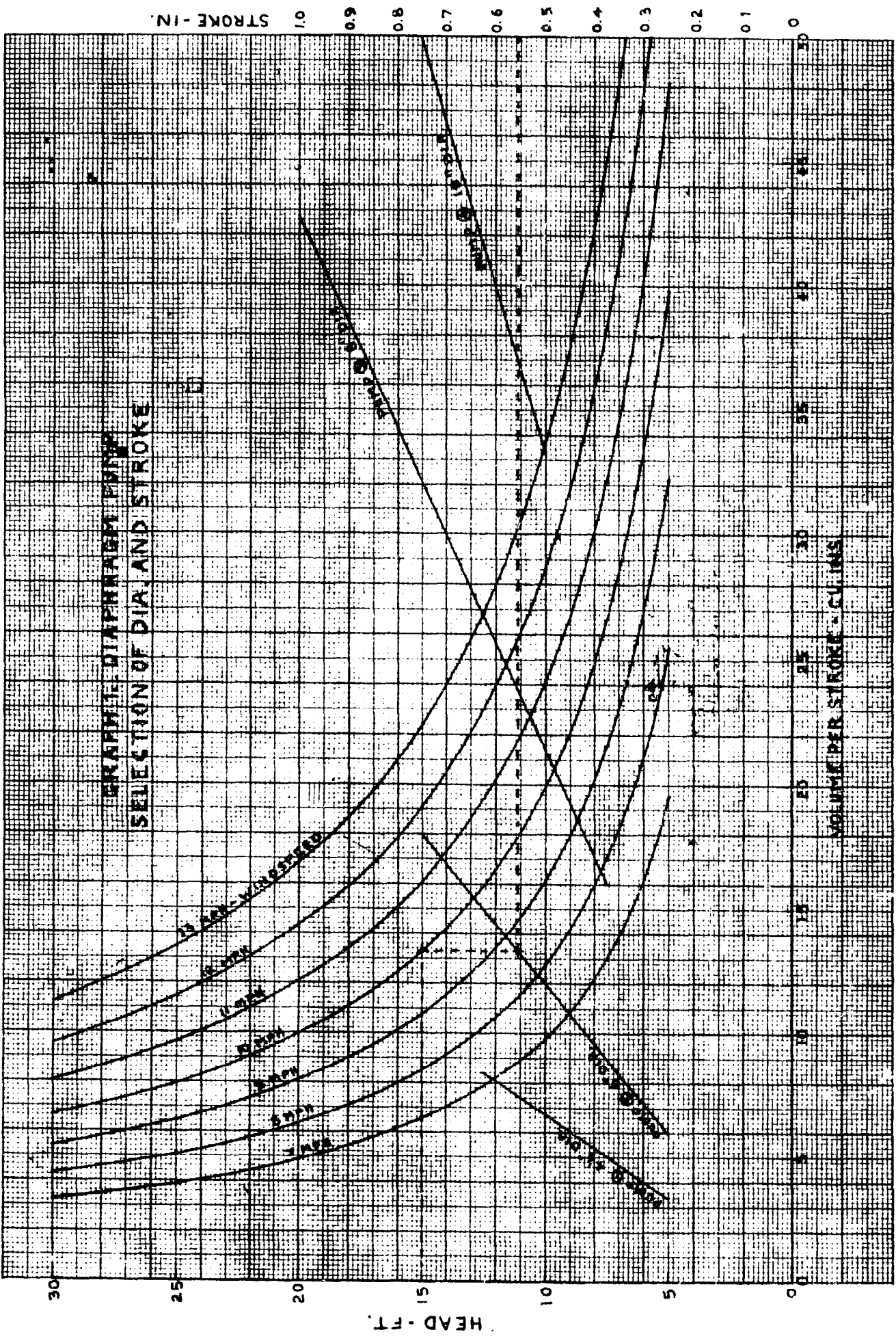

vertical dotted line to the base scale and read off 13.3 cu. ins./stroke. 13.3 divided by 3.14 (area of piston) gives a stroke of 4.23 ins.

To obtain this stroke of 4.23 ins. from the bell crank, it would be advisable to alter the eccentricity to get a more suitable ratio at the bell crank. If the eccentricity is made ½ in., then the stroke of the connecting rod becomes 1 in. This leaves a ratio of 1 4.23 at the bell crank, which could be divided into a vertical leg of, say, 2½ ins., and a horizontal leg of 10.58 ins. long. The bell crank would have to be shaped to conform to these measurements.

If a piston pump is used for this purpose, it must be a single acting pump, mounted below water level and operated so that the pump rod is only in tension. This will assure that there are no problems either due to buckling of the pump rod and connecting rod, or trouble with priming of the pump.

Estimating the Output of the Pump

Graph No. 2, Curve A, gives the output of the pump at the selected (rated) windspeed for the site in question, when pumping against a head of 10 feet. The output at the rated windspeed when pumping against a head other than 10 feet may be calculated from Curve A by simple proportion. For example, the pump which has already been selected from Graph No. 1, to pump against a head of 15 feet most efficiently in a windspeed of 10 mph., will have an output at 10 mph. of

$$W = 272 \times \frac{10}{15} = 181 \text{ Imperial gallons per hour.}$$

hour.

Note that, at windspeeds other than the rated windspeed, the pump will give an output somewhat lower than the figure read from Curve A of Graph No. 2, as it will no longer be operating at its best efficiency. For example, the performance of a particular pump is indicated by Curve B on Graph No. 2, which refers to a pump with a bore of 7-1/4 in. and a stroke of 7/16 in. The stroke has been selected to give optimum performance at a windspeed of 9.2 mph., and Curve B coincides with Curve A at this windspeed. However, as the windspeed increases (or decreases) progressively beyond the rated windspeed of 9.2 mph., the relative performance of the pump drops off and the actual output, read from Curve B, becomes a progressively smaller fraction of the optimum output, read from Curve A.

Pumping at Heads of More Than 30 Feet

In this leaflet consideration has been restricted to a very low cost pump and the simplest form of power transmission system. The equipment described above has been tested when pumping against heads of up to 30 feet.

However, it is frequently necessary to pump water to greater heights than 30 feet, but it must be emphasized that at higher heads and higher windspeeds the stresses in the pump and transmission increase considerably and the whole system would have to be stronger, more sophisticated and therefore more expensive. There would come a point when the simplicity and cheapness of the rotor would be cancelled by the cost of the drive and pump. No actual experiments have yet been made in this direction, but it is proposed to do so in the near future.

Until such results can be obtained it is up to the builder to adapt the present system for different conditions and requirements, bearing in mind that the system here described applies only to the moderate wind speeds and heads given in this pamphlet.

Cost and Materials

It is extremely difficult to define the actual cost of a project like this in dollars and cents. As in any "Do-It-Yourself" project, the biggest part of the job is the labour, which is assumed to be free. Depending on the skill, patience and resources of the home-builder, even the cost of the materials can vary considerably.

In the prototype described here, only the ball bearings, wood for the frame, and plywood for the rotor were purchased new. All other material was found around the place. The back of a garage or small machine shop is usually a good place to look for things like pieces of pipe, angles, bolts, etc. If no welding equipment is at hand, all the pieces to be welded should be carefully prepared, wired or clamped together and taken to the nearest welding shop. If everything is properly prepared, the actual welding for the whole job will not take longer than 1 hour. The only parts requiring machining are the shaft adaptors, the eccentric for the rotor, the flanges and discs for the diaphragm pump. All other work requires a drill only.

Finally, to give a rough idea of the cost, the main items are listed here as purchased in Barbados, in the equivalent of U.S. Dollars:—

2 Oil drums (good condition)	..	\$ 2.50
2 Self-aligning Ball Bearings, flange type	14.00
36 ft. 2 x 4 Timber	7.50
1 sheet ½ in. Plywood (4 ft. x 8 ft.)	12.50
80 ft. 1/8 diameter Galvanized Steel Wire30
6 1/4 x 4 ins. Turn Buckles	3.80
7 ft. 1-1/4 I.D. Water Pipe (Rotor shaft)	2.70
1 ½ in. Bore Ball Bearing (big-end)	1.60
15 ft. Plastic Pipe (delivery)	4.10
Bolts, Nuts, Washers, etc.	2.00
Total:	U.S. \$	51.00

**GRAPH OF DETERMINED UNIT
OUTPUT AT THE NOTED WATERHEAD
FOR A HEAD OF 15 FEET**

CURVE A

15.00

CURVE B

CURVE A SHOWS THE NORMAL DELIVERED HEAD A HEAD
OF 15 FEET X
CUMULATIVE DISCHARGE IN FEET. THE CURVE
REPRESENTS THE NORMAL
DELIVERED HEAD

CURVE B SHOWS THE VOLUME OF WATER
IN ONE DAY OF OPERATION WITH A
HEAD OF 15 FEET

X - WATER DELIVERED AT NOTED HEAD - THE CALDERHEAD

0 100 200 300 400 500 600 700 800 900 1000

TECHNICAL NOTES ON THE DIAPHRAGM PUMP

1. The diaphragm should be of fairly thick rubber
 - rubber from heavy truck or tractor inner tube is good
 - rubber that is too thin or too flexible is not satisfactory since under a large head the deformation of the diaphragm tends to negate the full diaphragm displacement.
2. The stroke may well have to be increased to one or two inches, depending on the rubber flexibility. In order to effect this, it may be necessary to increase the clearance between the discs and the pump body.
3. It was found, in practice in very remote conditions, that a fair bit of experimentation was needed in order to determine the best location of the pump relative to both the source and the discharge. This pump is most efficient when immersed, however the pressure head then becomes too great and diaphragm deformation becomes very significant. For our 4½" pump, a suction head of about 6 to 8 feet with a pressure head of some 8 to 10 feet was felt to be about the limiting conditions.
4. The pump rod and connecting rod end connections should be firm. Any play in these takes away from the length of stroke.

Centro Internacional de
Agricultura Tropical
Apartado Aereo 67-13
Apartado Nacional 737
Cali, Colombia

BRACE RESEARCH INSTITUTE

MACDONALD COLLEGE OF MARYLAND UNIVERSITY

ESTATION DE RECHERCHES

QUIBERON, CANADA

MOLINO CARIMAGUA

Cada año se presenta una tragedia en los Llanos Orientales de Colombia cuando se mueren miles de vacas por falta de agua. En Casanare las distancias entre los ríos y caños (que son las únicas fuentes de agua durante el verano) son largas y el ganado se ve obligado a mantenerse cerca al agua, y por lo tanto se acaban los pastos aledaños al agua, o a caminar distancias demasiado grandes. En Meta y Vichada, los caños y ríos veraneros son mucho más abundantes pero a medida que el agua baja se aumenta el riesgo de que el ganado (especialmente las vacas viejas) se entierre en busca de agua y si no lo sacan dentro de pocas horas de haberse enterrado, se muere.

La tragedia descrita parece absurda al darse cuenta que en todas estas regiones existe agua subterránea abundante a muy pocos metros de profundidad.

El ICA y el CIAT en su preocupación por encontrar una solución económica al problema de agua han instalado un molino experimental en Carimagua que parece muy promisorio. El molino representa una modificación de un diseño realizado, probado y publicado por la "Brace Research Station" en Barbados. El diseño fue basado en un rotor inventado por el finlandés Savonius en 1925.

El Molino es de construcción muy sencilla, bajo costo y fácil mantenimiento. Se ha estimado que el costo de materiales, incluyendo trabajos de taller que no serían factibles en el campo sería de aproximadamente \$2.500 (unos colombianos equivalentes a \$125.00 U.S.) El costo está basado en un pozo de 9 metros de profundidad, con anillo de boca y tapa en concreto reforzado y en una torre de 8 metros hecha de madera rolliza en forma de trípode con bases de concreto.

En la zona de Carimagua se ha estimado el costo del molino, hecho por contrato e incluyendo el molino, la excavación del pozo, hechura del anillo y la tapa en concreto y la torre en madera rolliza cortada en la finca en \$4.500.00 (\$225.00 U.S.)

No existen datos concretos sobre rendimiento. Se midió en forma bastante rústica un rendimiento de aproximadamente 500 galones/hora cuando el nivel del agua estaba a 8 metros, con un cilindro de molino de 3" y una brisa estimada de 6-8 Km/hora. La carrera del pistón era de 2 cm[±]. Se puede variar la carrera del pistón fácilmente según la estación. En época de verano cuando hay mucha brisa, parece indicado aumentar la carrera y así reducir la velocidad del rotor. En cambio, en época de invierno, es conveniente reducir la carrera, para que el molino comience a bombear con una brisa mínima.

Background Information on the Brace Research Institute

Brace Research Institute of McGill University was founded in 1959 to develop equipment and techniques for making dry lands available and economically useful for agricultural purposes. The Institute has concentrated on the problems affecting individuals or small communities in rural areas and is one of the few organizations with this basic objective.

In general, equipment developed by this Institute utilizes as many local resources as possible, whether human, energy or material, so that the technology can be easily adapted to the local environment. As a result, the Institute has concentrated on utilizing solar and wind energy as well as simple desalination systems, specifically concentrating on the problems that face isolated rural populations in developing arid areas.

Instructional manuals are available describing the use of solar energy for the

- 1) heating of water for domestic and commercial use
- 2) cooking of food
- 3) drying of agricultural produce
- 4) desalination of water for human, animal and agricultural use.

The adaptation of simple greenhouses combined with solar desalination systems for the production of food and water in arid areas is also being developed. The Institute is also adapting greenhouses to make better use of solar energy to reduce heating costs in colder regions.

In addition, simple windmills for the production of electricity and the pumping of water have been developed.

Further inquiries should be directed to

Brace Research Institute,
Macdonald College of McGill University,
Ste. Anne de Bellevue, Québec,
H9X 3M1,
Canada.

Other leaflets available:

	<u>Price</u>
L-1 - How to Make a Solar Still (plastic covered)	\$1.25
L-2 - How to Make a Solar Steam Cooker	\$1.25
L-3 - How to Heat your Swimming Pool using Solar Energy	\$0.75
L-4 - How to Build a Solar Water Heater	\$1.25
L-5 - How to Construct a Cheap Wind Machine for Pumping Water	\$1.25
L-5F - French version of L-5	\$0.75
L-6 - How to Make a Solar Cabinet Dryer for Agricultural Produce	\$1.25
L-7 - Arabic Translation of L-6	\$1.25
L-8 - Spanish Translation of L-6	\$1.25
L-9 - French Translation of L-2	\$1.25
L-10 - French Translation of L-6	\$1.25
T-17 - Simple Solar Still for the Production of Distilled Water*	\$1.25

Please remit payment with money order or add \$0.25 to your cheque for bank handling charges.

* Also available in French, Arabic and Spanish.