

Oxfam Water Supply Scheme for Emergencies

This equipment is part of several packages devised by the Oxfam Public Health Engineering Team to help provide a reliable water supply for populations affected by conflict or natural disaster. The equipment is designed to be used with any or all of the following Oxfam water equipment: Water Pumping equipment, Water Storage equipment, Water Filtration equipment, Water Distribution equipment, Hand-dug Well equipment, and Water Testing Kit. All are designed using available, easily transported equipment which is simple, rapidly assembled, and fully self-contained, to provide an adequate, safe water supply at moderate cost. The principles used in these packages may often be useful in long-term development projects.

The Oxfam equipment packages which consist of Oxfam tanks (steel sheets, rubber liners), diesel water pumps, 3" PVC pipes etc, have been used successfully in the last two decades in often harsh environments, ranging from tropical to temperate climatic areas. Although this equipment is designed for emergencies, if installed and protected adequately it can give many years of useful service, though some up-grading works will be necessary to prolong its life. This equipment can be dismantled and re-used elsewhere.

However, these Oxfam equipment packages, while being simple to erect over a period of days, yet durable enough to last several years, do not lend themselves to very rapid deployment in a few hours. Increasingly, the nature of work which Oxfam has been required to undertake, has required equipment that can rapidly deployed, then dismantled and moved to other locations and this has led to the development of the so called "rapid response kits" since the mid 1990s. This type of equipment is seen as a necessary complement to the original Oxfam equipment and is best used to provide a start up package in the absence of a detailed assessment and where affected populations are likely to be highly mobile. The relatively higher equipment costs and lack of suitability for anything other than short term water supply, means that the deployment of the "rapid response kits" should be used only where appropriate.

Read this manual through before starting installation.

Contents

SECTION A - EQUIPMENT USE AND SYSTEM DESIGN	2
Coagulation	2
Disinfection	4
SECTION B – LIST OF KITS AND INSTRUCTIONS FOR USE	6
Coagulation and disinfection kits	6
Coagulation	7
Sedimentation - upflow clarifier	8
Disinfection	13
SECTION C - OPERATIONAL INFORMATION	15
Coagulation and flocculation	15
Chlorination	19
SECTION D – DETAILS OF KITS AND SUPPLIERS	22
Full list of kit contents	22
List of suppliers	25

SECTION A - EQUIPMENT USE AND SYSTEM DESIGN

Wherever possible, water supplies in emergency conditions should be obtained from underground sources, by exploitation of springs, tubewells, or dug wells; as treatment requirements are minimal, because water from these sources is usually low in physical and microbiological contamination. However, in an emergency, such a source may not be available or it may take a long time to develop and the use of surface water from streams, rivers, lakes, or ponds may become necessary. Usually these surface sources are polluted with both physical and microbiological contamination.

The use of chemicals to assist in treatment of water is often necessary where water needs to be provided from these contaminated surface water sources, particularly in the early stages of an emergency. While the use of the roughing and slow sand filtration (see Oxfam filtration equipment manual), should be considered for post emergency situations as these treatment methods are more sustainable and appropriate, the relatively speed and efficiency of using chemical treatment methods justifies their use during the early stages of an emergency response. The principles of using chemicals for water treatment apply to both household level (small scale) and treatment plant level (bulk centralised production), but the equipment and methodologies discussed in this manual apply primarily to bulk water treatment.

SPHERE recommends maintaining a chlorine residual of 0.2-0.5 mg per litre and turbidity below 5. Where water is not disinfected, there should be no more than 10 faecal coliforms/100ml at point of water delivery. The recommended figure of 15 litres / person / day is used for water supply and this figure is based upon; water requirements for food preparation and consumption, which require higher quality water, as well as water needed for clothes washing and bathing. Where nearby sources of water such as streams and rivers are available and the safe use of these for washing clothes and bathing can be managed, it may be appropriate and necessary to initially size the treatment system on a figure of 10l / person / day. This would provide the water required for food preparation and drinking, i.e. a minimum of 5 litres/person/day and additional water to allow for subsequent increased demand, perhaps due to population expansion.

Oxfam uses two basic types/stages of treatment process for treatment of physically and microbiologically contaminated (surface) water:

1. Water (surface) with high physical contamination, i.e. suspended solids (which often has high microbiological contamination too), needs to be treated using plain sedimentation or a combination of coagulation and flocculation followed by (assisted) sedimentation. Thus the primary role of this stage of treatment is to reduce physical contamination – though it does also have a limited ability to reduce microbiological contamination.

2. Water (surface) with low physical contamination but with high microbiological contamination can be treated by disinfection only. Thus the primary function of disinfection is to eliminate microbiological contamination – there is little scope for efficient disinfection with chlorine where there are high levels of physical contamination (<5NTU).

Note: physical contamination is due to suspended solids - approximate estimates of which are made by measuring turbidity (NTU).

Coagulation

Coagulation with aluminium sulphate

Where high levels of suspended solids exist in the water, reduction of these is necessary in order to be able to disinfect effectively with chlorine and for aesthetic (looks/taste) reasons. Plain sedimentation of solids suspended in water is often slow, but is readily assisted by addition of a coagulant, which causes the solid particles to aggregate (stick) together and so to form larger masses, which settle more rapidly. While effective intake design and plain sedimentation can remove larger particles, colloidal (very fine) matter and organic material such as algae, is often difficult to remove without use of a coagulant.

The coagulant most commonly used by Oxfam is aluminum sulphate powder (Oxfam code FAS), which though not a very strong coagulant, does have the advantage that it can be air freighted easily and is quite commonly available in different parts of the world. However, it does have quite a narrow pH range, operating best between pH 6.5

and 7.5 and outside these limits its efficiency goes down and hence more has to be used to compensate. This occurs as the solubility of aluminium precipitate increases dramatically outside this range, which means that where pH is too high or too low, a floc precipitate will be unable to form easily.

As the addition of (acidic) aluminium sulphate to water lowers the pH (by reacting with its natural alkalinity), there is a risk that water pH may fall outside the optimum range. Where water has insufficient alkalinity or buffering capacity, additional alkali must be provided, usually by the addition of Quick lime, as this will raise the pH of the water. As a guide, around 7 – 14kg of lime added to 95m³ of water will provide an appropriate level of pH adjustment, though clearly the actual amount should be determined as part of the jar tests.

Coagulants such as ferric chloride and ferric sulphate can be ordered and these operate in a wider pH range, but are more hazardous, making them more difficult to transport by air and they are less commonly available. Coagulant aids can also be used where water is particularly difficult to treat, even by coagulation and Oxfam is investigating the use of these as a start up option in acute emergencies to increase the effectiveness of aluminium sulphate.

Jar tests should be performed to determine the correct dose of coagulant to use. This will probably be in the range between 25 - 150g/m³ for aluminum sulphate, but will depend upon the raw water to be treated. Details of how to undertake a jar test are given in Section C.

There are three main stages in using a coagulant and these can be achieved in a variety of ways, choice being dependent upon equipment being available and local circumstances;

1. Dosing of coagulant
2. Floc formation - flocculation
3. Sedimentation

Dosing of aluminium sulphate

There are several options that Oxfam uses for addition of aluminium sulphate (and some other coagulants) to water;

1. By suction side dosing, using the suction side dosing kit (Oxfam code FASD). The coagulant is sucked into the water stream by the pump and undergoes rapid mixing in the pump chamber.

2. By use of a barrel erected at edge of, or in the tank to drip into inlet or outlet flow. Either a 200 litre-oil drum could be used or the equipment in the constant head dosing kit (Oxfam code FCCD).

3. By use of a precise chemical dosing pump (Oxfam code FDO), which is powered simply by a small hydraulic head (minimum of 1m). Though these have been thoroughly tested and a specification prepared for them (see section D), they are not stocked and this manual does not deal with them in any further detail.

Flocculation

Once the coagulant has been added (dosed) to the water supply, the right conditions need to be created to enhance the process of floc formation. Typically after a period of rapid mixing/injection into the water stream (as achieved with suction side dosing where water is churned through the pump chamber), the water/coagulant mix should be gently stirred to permit the smaller flocs to come together. Care must be taken not to have the flocs broken up by too strong mixing.

Oxfam uses two basic methods for achieving this;

1. The use of a coiled pipe flocculator, especially in conjunction with suction side dosing, is much more efficient way of achieving good flocculation and has been recently introduced to Oxfam.
2. Attaching a 2/3m length of hose onto a coagulant/flocculent tank inlet and fixing this along the circumference of the tank to create a circular stirring motion within the tank during the time in which water is being pumped/led into the tank. This method is the traditional practice but it is less efficient than the coiled pipe flocculator.

Sedimentation (coagulant assisted)

Once the coagulant has been introduced into the water and flocs are starting to form, a period of time is required for these to settle out of the water and form a sediment at the bottom of the tank, enabling clean water to be removed from the clear water above this. The use of specially designed sedimentation tanks complete with special inlet, outlet arrangements and other features, does increase the efficiency of sedimentation and allows a much greater level of process control. However Oxfam or onion tanks can be used to provide a very basic sedimentation tank which will achieve

the separation of most of the flocs from the treated water. Good dispersion of the aluminium sulphate throughout the water to be treated should be ensured before it is introduced to the tanks. Agitation of water in the settlement tanks must be minimised. Aluminium carry over into the water supply should be measured by checking the presence of aluminium with a comparator (available in Oxfam kit, code FMT) at the tank outlet.

Oxfam uses two basic methods of achieving sedimentation:

1. Simple sedimentation in batches, either in Oxfam tanks or Onion tanks. This is the simplest way of achieving this as it requires only basic equipment (i.e. tanks) though it provides little process control, with the risk of both suspended solids and coagulant carry over into the water supply. Once pumping of water into the tank has been completed, water will typically have to sediment between 2 and 6 hours (actual time determined by a jar test) and thus water production rates can be calculated accordingly.
2. Upflow clarification, which is an advanced sedimentation process, usually run on a continuous basis, which allows a considerably greater level of process control. The Upflow clarifier kit has been developed very recently to be able to achieve this and it warrants a further description because it is so new.

The upflow clarifier.

Oxfam has developed a completely new piece of equipment for use with water treated by coagulants and this can be built inside an Oxfam T11 tank. The evolution and testing of the Upflow clarifier kit (Oxfam code FUC), which though incorporating treatment technology used in permanent water treatment plants, has a number of unique design features to enable it to be engineered to fit into a "rapid response package".

The upflow clarifier has been designed to fit into a complete water treatment system package, which combined with a pump, aluminium sulphate and chlorine dosing systems, offers a fairly rapid and very robust continuous treatment process capable of dealing with high levels of turbidity. The system will take between half and one day to set up, including time taken to erect the T11 tank and to reach stable operating conditions. The system has been tested and can produce between 7-9m³/hr, with turbidity reduction from NTU500 to under NTU10, but actual production and performance is dependent upon raw water quality. As it is

essentially a sedimentation system, it requires considerably less cleaning and maintenance than pressure filtration systems, which often take less time to set up, but soon lose this benefit with complex cleaning regimes that result when highly turbid water (much above 50 – 100 NTU) is being treated.

The various stages in the Upflow clarifier package are:

- Dosing of aluminium sulphate, either by having a Tee on the suction hose of the pump, or from the outlet of a raw water/sedimentation tank or hydraulic dosing pump, to dose the coagulant into the water to ensure that it undergoes rapid mixing.
- Flocculation by passing through 2 parallel coils of 3" layflat hose wrapped around the Oxfam T11 tank, each 30m long, which act as flocculators by gently stirring the water as it passes through the coils of the pipe.
- Sedimentation in the T11 tank in which the upflow clarifier is built, where some flocs should already be forming.
- Final filtration through a "polishing" fabric filter installed at the top of the tank. Water low in suspended solids will flow out from the top of the clarifier and through the tank outlet.
- Chlorination at the outlet, where chlorine is added by the constant head chlorine dosing device

Disinfection

Chlorine is the chemical most widely used for disinfection of treating drinking because of its ease of use, ability to measure its effectiveness, availability and cheapness. Under the right conditions chlorine will kill all viruses and bacteria, but some species of protozoa and helminthes are resistant to chlorine. WHO recommends adequate protection of the source as the most effective way of dealing with these more resistant helminthes and protozoa by preventing faecal contamination entering the water.

Protozoa and helminthes are difficult to detect directly, but where these are thought to be a risk, it may be necessary to resort to use of Membrane filters to strain out these organisms (the smallest of these are Giardia cysts at 7-10microns, while Cryptosporidium oocysts are 4-6 microns). However though these are able to produce high quality water, they will not provide much water quantity for a low capital investment and thus the

cost of purchasing these may not be warranted where financial resources are limited and the risk of contamination is thought to be low.

If the water to be disinfected contains a lot of suspended solids and/or organic matter (i.e. is highly turbid), it will have a high chlorine demand. WHO guidelines recommend that turbidity is less than 1 NTU for chlorination to be effective in destroying all bacteria and viruses, though 5 NTU is a more achievable limit and will be adequate in most cases. It is, therefore, desirable to remove suspended solids as much as possible before the chlorination process begins. This will significantly reduce the amount of chlorine needed and improve its efficiency as a disinfectant.

Oxfam uses chlorine in two forms; HTH - calcium hypochlorite granules (Oxfam code FCH) and slow dissolving chlorine tablets (Oxfam code FCT).

There are several options that Oxfam uses for addition of HTH chlorine to water:

1. By mixing a 1% solution in a suitable bucket or container and adding to a tank on a batch basis.
2. By use of a constant flow dosing arrangement to drip 1% chlorine solution into outlet flow from a tank, as found in the constant rate dosing kit (Oxfam code FCCD)
3. By use of a precise chemical dosing pump (Oxfam code FDO), which is powered simply by a small hydraulic head (minimum of 1m). Though these have been thoroughly tested and a specification prepared for them, they are not stocked and this manual does not deal with them in any further detail.

The chlorine tablets (Oxfam code FCT), which give a slow release of chlorine over a period of several days, using the floating pot chlorinators (Oxfam code FPP) have quite specific usage where a slow release of chlorine is useful.

SECTION B – LIST OF KITS AND INSTRUCTIONS FOR USE

Coagulation and disinfection kits

This manual explains how to use/erect the following kits/water treatment chemicals (detailed kit lists are provided in section D):

Oxfam code	Description
FAS	Aluminum sulphate (1/2 tonne)
FASD	Alum suction side dosing kit
FCCD	Chlorine constant rate dosing kit
FCH	HTH chlorine powder
FCT	Chlorine tablets (trichloroisocyanuric acid)
FFP	Floating pot chlorinator kit
FUC	Upflow clarifier for T11 tank

The Upflow clarifier will require a T11 tank in which this is built, along with storage tanks for raw and product water storage, and a pump to operate the Upflow clarifier directly or to fill any raw water tank used. In order to maximise the speed with which the Upflow clarifier can be deployed; it is recommended that the rapid response pump (PR2) and tank (TRR30) are used, though other Oxfam tanks and pumps are also suitable.

Oxfam code	Description
T11	11m ³ Tank sheets, liner and roof
TRR30	30M ³ Onion PVC tank
PR2-ALBS	2" Pump Sets, Petrol, Lightweight Pumpset Kit

In addition specifications have been prepared for other kits which are much less often used, and though not stocked by Oxfam or their use explained in this manual, further advice can be sought from Oxfam GB emergencies department and they can be ordered if required.

Oxfam code	Description
FDO	Chlorine/aluminum sulphate dosing pump
FEG	Electrolytic sodium hypochlorite generator
FMF	Microfiltration membrane for protozoa removal (specification in preparation)

Where chemicals, particularly chlorine are being used for water treatment, it is recommended that some form of protective clothing is provided for operatives handling the chemicals. Though not a stocked kit, the following is available at short notice for this purpose.

Oxfam code	Description
XSO	Vector/chemical safety outfit for 2 people

The layout diagram below shows the clarifier in use with a pump (option A), which can be phased out later and replaced with a raw water/header tank (option B).

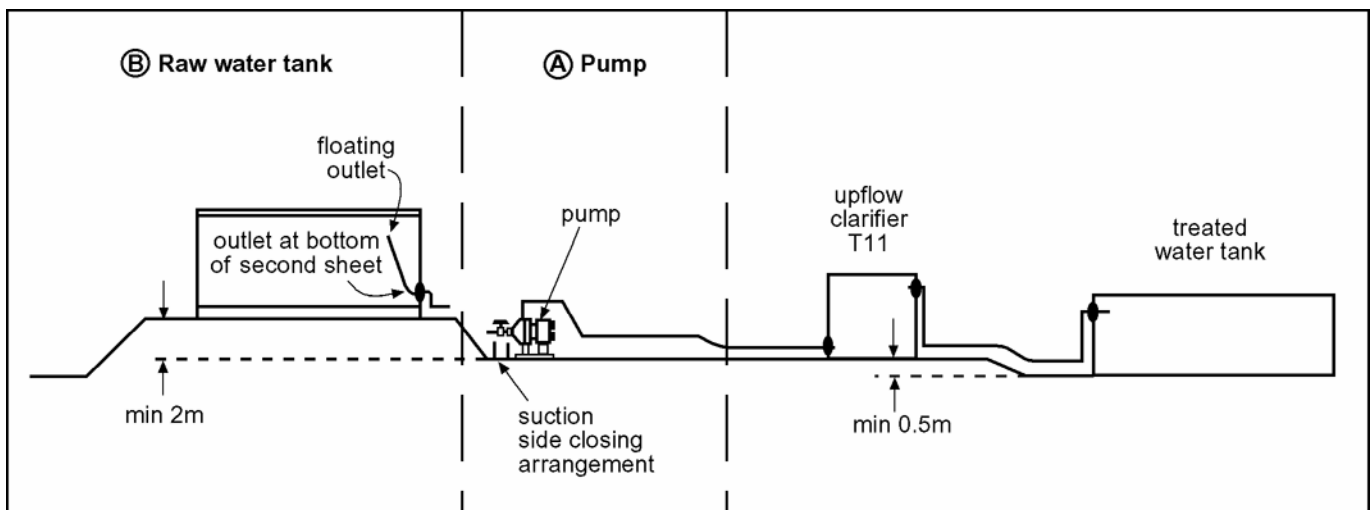

Coagulation

Dosing

1. (Oxfam code FASD) The suction side doser consists of a coagulant vessel, with a needle valve attached at the outlet. The doser is suitable for use with all Oxfam pumps as the kit is supplied with 2" and 3" reducers for the 4" fittings. A gate valve is supplied on the line for pressure adjustment, which may be required for the smaller P2 and PR2 pumps. (Note that the longer the pump suction line, the greater the risk of air bubbles occurring within the raw water flow.) Though the use of the suction side doser is good as it allows rapid mixing of the coagulant in the pump chamber, continued use for periods of several months is not recommended as the caustic nature of the coagulant will progressively corrode the pump chamber. The overall control of dosing can be achieved by varying coagulant flow with the needle valve or coagulant solution concentration – flow will be estimated by timing the volume discharged from the coagulant vessel. This method of dosing is appropriate where water is being pumped directly into an upflow clarifier (see below) or into an onion or Oxfam storage tank which being used as a sedimentation tank.

2. Where the upflow clarifier is being used and water is being pumped to a storage tank before being emptied into an upflow clarifier, the suction side doser cannot be used, as mixing of the coagulant needs to occur immediately prior to entering into the upflow clarifier. Instead the coagulant vessel (in Oxfam code FASD) can be set up to float directly on the surface of the water and feed coagulant to the outlet of the tank. The end of the feed hose needs to be carefully tied at the entrance of the tank outlet. As the coagulant is released into the stream of water entering into the outlet, limited mixing occurs at this point before going into any coiled pipe flocculators. An optional in-line mixer could also be installed to improve mixing.

3. Alternatively where a simple form of coagulant assisted batch sedimentation in water storage tanks needs to be undertaken, the coagulant needs to be introduced into the flow of inlet water to provide some limited rapid mixing and the tank then functions as a sedimentation tank. This can be accomplished using the vessel in the chlorine dosing kit (Oxfam code FCCD) which can be positioned in the bracket attached to the top of an Oxfam tank, with the feed line projecting through

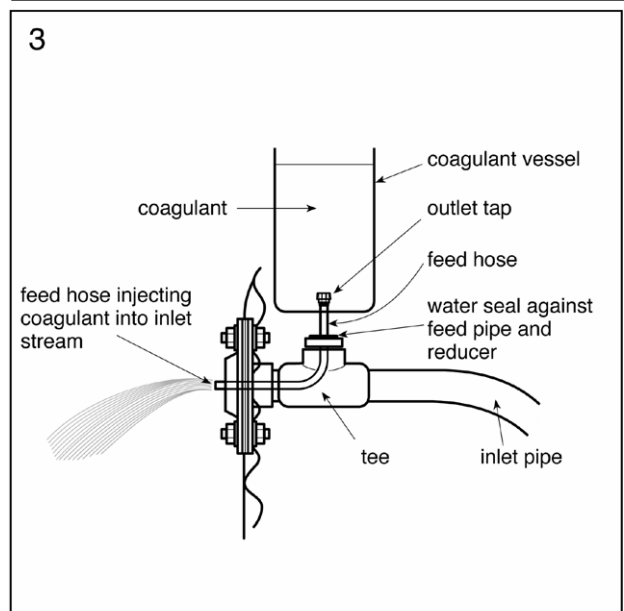
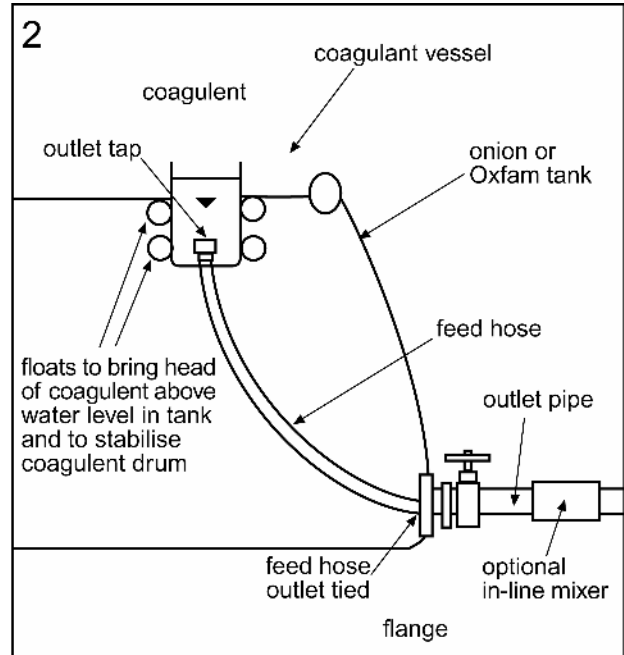
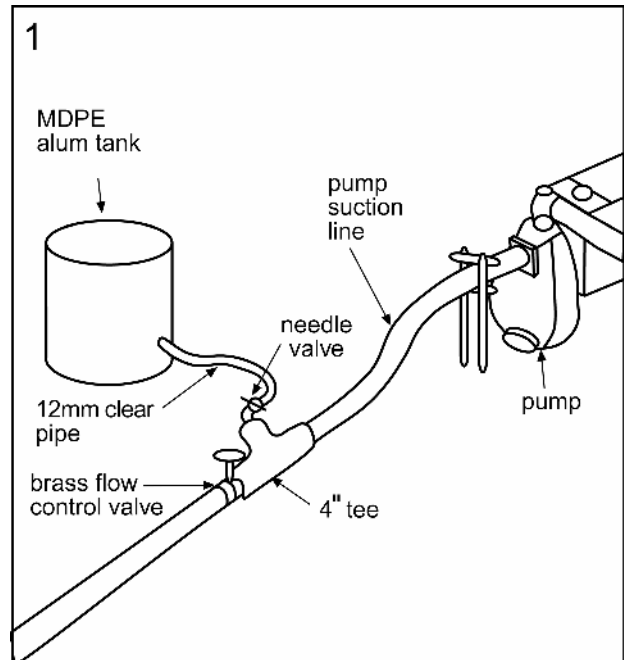

the Tee and into the incoming water flow and coagulant introduced at a constant rate.

Flocculation

4. The coiled pipe flocculator can be made by coupling together several lengths of 3" green flexible hose. This hose is suitable as it has quite tight radius of curvature and as is it a standard piece of Oxfam equipment. The length should be determined to ensure that water has a residence time between 2 and 6 minutes in the coils.

Sedimentation - Upflow clarifier

Assisted sedimentation in Oxfam or Onion tanks is not shown. Kit components are numbered as per the specification list in order to assist assembly.

5. The T11 tank should be erected as per the instruction manual for the T11 tank, but making sure that the two sheets with double outlet holes in, which are for the inlets and sludge outlets, are positioned with the holes at the bottom of the tank, directly opposite each other. One outlet hole should also be provided at the top of the tank in a position convenient for treated water flow to storage tanks. Cut the liner to have 5 holes in it, four at the bottom and one at the top to match the inlets/outlets. (One tank sheet with single hole in it will remain unused and should be blanked off using a spare blanking sheet from one of the other sheets.) [See animation Power Point](#)

6. The 2-inlet flange assemblies complete with elbow welded to them should be installed directly opposite each other, with the elbow pointing vertically upwards. In each of these, the length of GI pipe should be inserted and finally the double elbow arrangement screwed into the top to point downwards to allow water to enter tank with down flow velocity component. The other two lower flange assemblies can be completed and tightened up, using flanges from the T11 tank kit. The top flange assembly should have the inside face left off, until the funnel is positioned (see below 8). [See animation Power Point](#)

7. The metal sump assembly should be positioned in the centre of the tank (measuring approximately 1 metre from the edge of the sump to the tank wall) lining up the two sludge washout sockets in the sump with the remaining unused flanges in the tank sheets. (The third outlet in the sump should be ignored as this will not be used.) The sump depth assumes that the bottom tank sheet is dug 50mm into the ground. On hard ground where excavation is not possible, the sump will need to

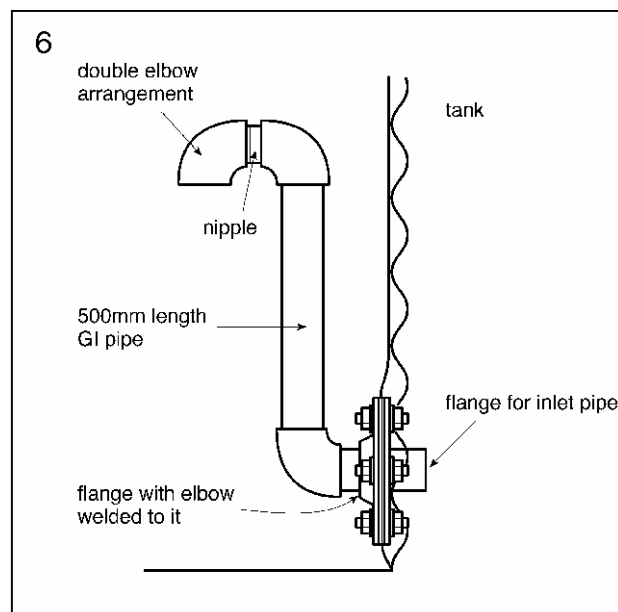
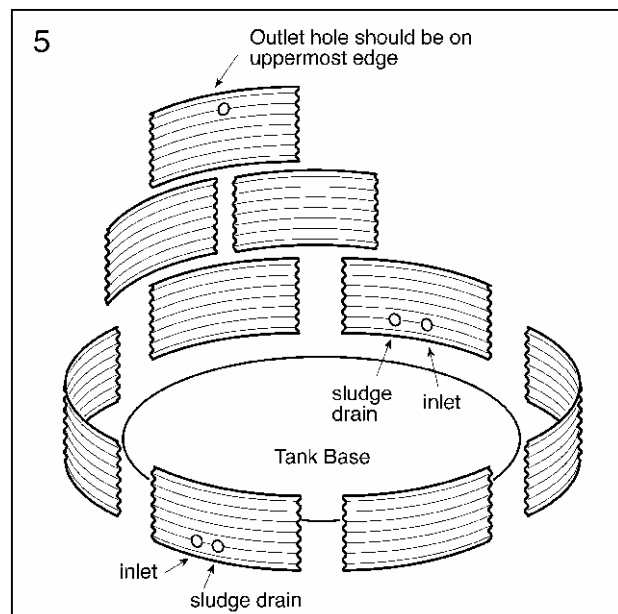
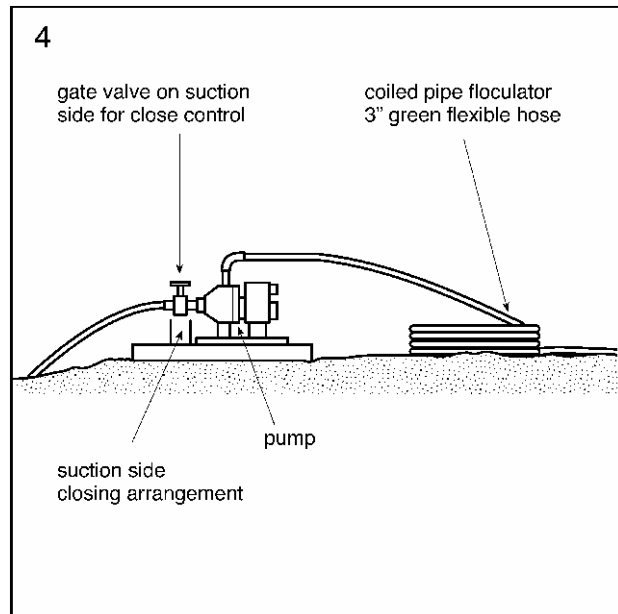

be raised by packing 50mm of wood or flat stones beneath it.

One of the sludge drain pipes, consisting of 1 length of 3" BSP pipe threaded each end, a 3" tee and another length of 3" pipe threaded one end, should be connected firstly into the flange, then the sump slid over the non threaded end of the pipe. The second sludge drain should be installed by screwing the length of pipe into the flange, adding the tee and finally adding the other straight section of pipe, by first sliding it into the sump socket, lining this up with the tee and sump socket, lining this up with the tee and screwing this into the tee. Ensure that these tees for draining behind the cone are aligned horizontally to allow maximum draining of the tank. [See animation Power Point](#)

8. The PVC clarifier funnel should be unfolded and with one person standing inside the sump, this should be lowered by about 4 people, with the narrow end of the funnel lowered over the body of the person standing in the sump, until the edge of the funnel is about 100mm above the top of the sump.

19 barrel strainers should be attached to the sump, using the nut and bolt to fix these in an upright position. The 19 barrel strainers should be adjusted so that they are screwed out to mid point of their adjustable length. They can then be connected from the eyelets in the funnel to the holes in the lip of the sump. (see diagram 10)

The four people should then pull up the funnel until it is fairly taut and the top section pulled over the edge of the tank. This is most easily achieved by pulling down the edge of the funnel with the special tool which hooks into 2 adjacent eyelets, while someone inside the tank lifts the funnel up off the tank lip using the pole/broom handle. Working progressively around the tank, the funnel can be slowly eased into place, till around 100-150mm of the funnel material is folded down over the outside edge of the tank. This should then be tied off with the elastic (bungy) straps provided, to the eyelets on the tank sheets and in the funnel. [See animation Power Point](#)

9. The PE retaining hoop should be assembled on the ground by using the four pieces of 50mm PE and the threaded plastic rod complete with backnuts. The back nuts should both be screwed into the centre of the threaded rod to allow maximum insertion into the PE pipe. The funnel retaining hoop should be lifted into the tank and

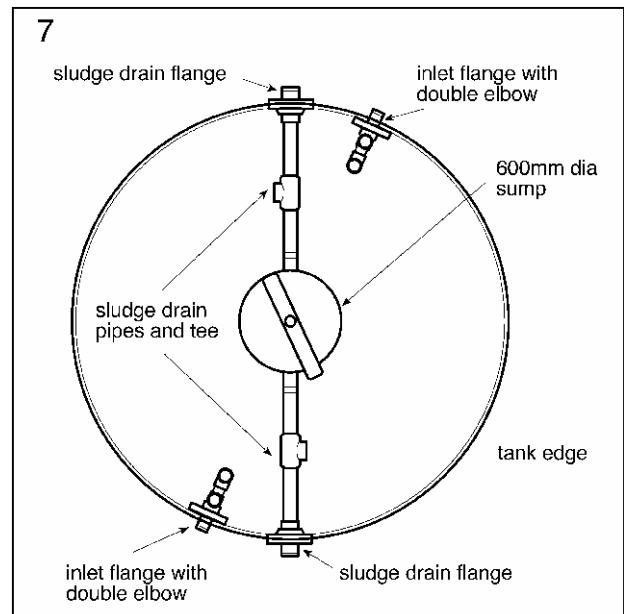

positioned in a corrugation about 400mm down

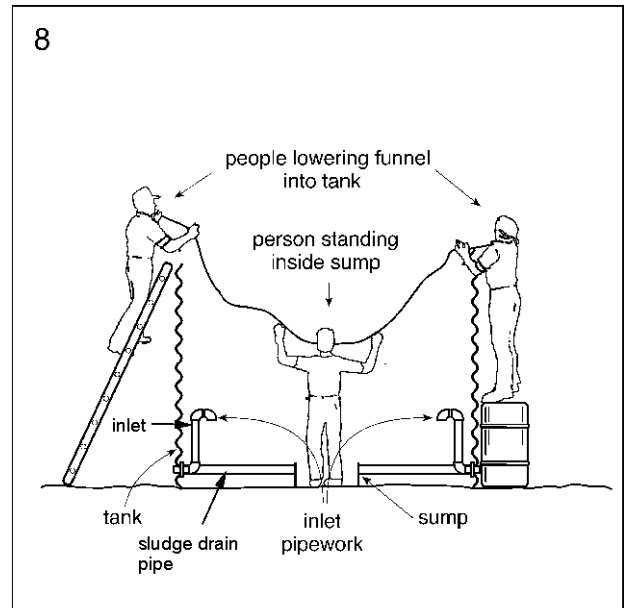

from the top of the tank (see diagram 12). Once

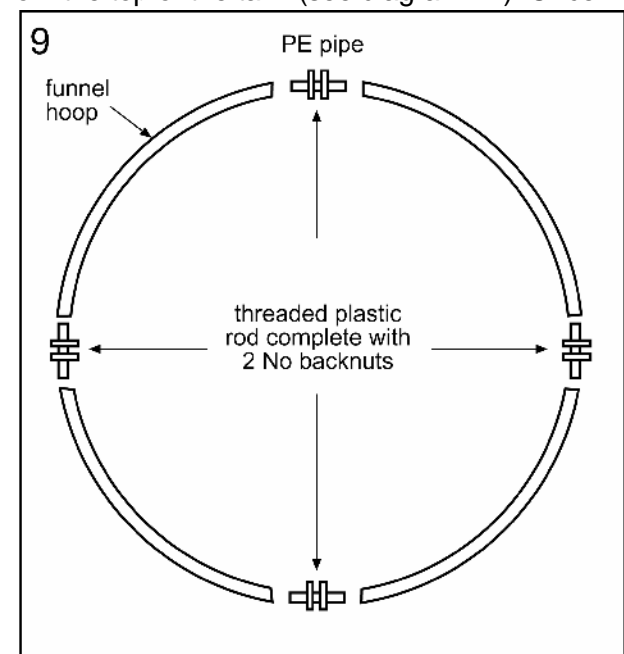

the correct position in a corrugation has been located, the backnuts should be screwed in opposite directions to expand the hoop firmly into a corrugation. This will have the effect of tightening the funnel even more.

10. The person inside the sump should then make final tensioning adjustments using the barrel strainers to ensure that the funnel fabric is very tight. Then with the assistance of a ladder positioned inside the sump, this person can climb out. Now the funnel should have the outlet hole cut in it and this should be positioned over the flange studs. The outlet flange can now be added and tightened up, positioning the second flange gasket adjacent to the funnel before positioning the flange. [See animation Power Point](#)

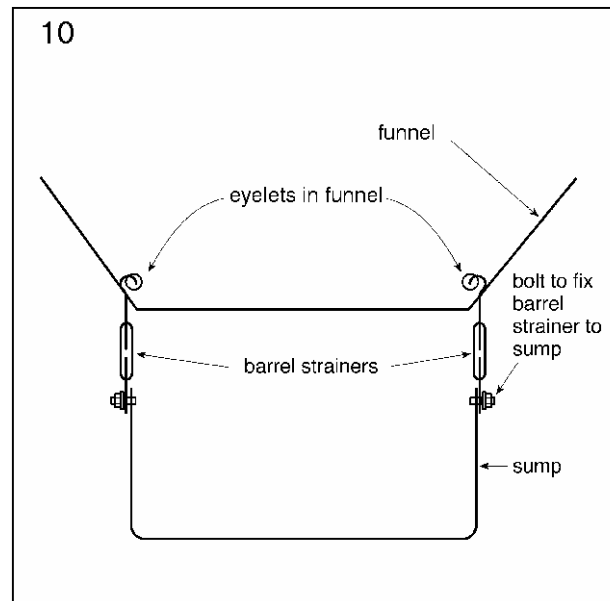

11. The six tank hinge assembly brackets should be loosely fixed to the vertical tank sheet joints. Each of the tubular steel painted segments should have two of the steel tubes complete with eye welded to an end screwed into place. The segment with the outlet pipe support bracket attached (see 15. Below) should be positioned opposite the tank outlet. Then the other segments can be lifted into place and by moving the tank hinge assembly bracket from side to side, the eye on each side can be hooked over a lug attached to the brackets. Note: Ensure that the two segments with the attachment for overhead beam are placed opposite each other. Once all segments are in place brackets can be bolted tightly to the tank so they don't move. [See animation Power Point](#)

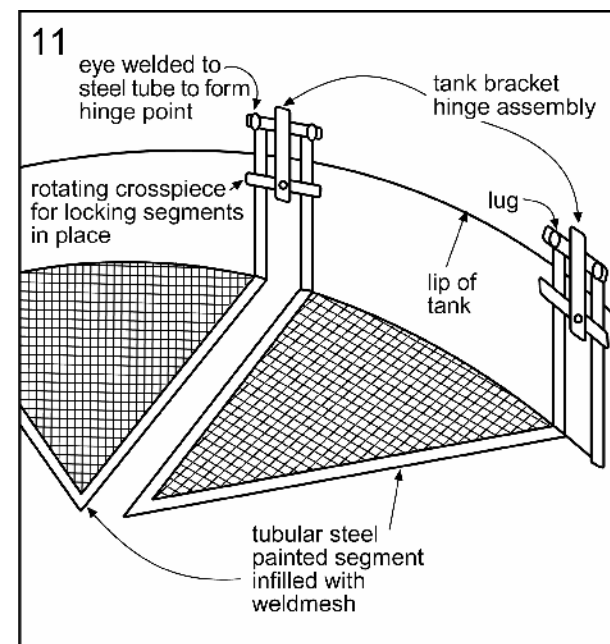

12. The fabric polishing filter should only be positioned once raw water has been run through the system and the height of the floc blanket determined (see operation and maintenance below). Once this has and the optimum flow set by adjusting the inlet gate valves accordingly, the fabric-polishing filter can be positioned. The water level in the tank should be lowered below where the filter should be positioned, by draining the tank in preparation for filter installation. Lift the 6 segments so that they are all folded out of the tank. Unfold the fabric polishing filter and layout over the top of the tank, cutting 100mm long slots where the hinge assembly brackets occur and tying ropes to the edge of the fabric to keep it folded over the lip of the tank. Fold the segments into the tank, keeping the filter fabric taut on the underside of the segments. Tie the fabric edge to keep it falling into the tank (otherwise progressive blocking of the fabric may result in water by passing the fabric filter if the edge falls into the water).

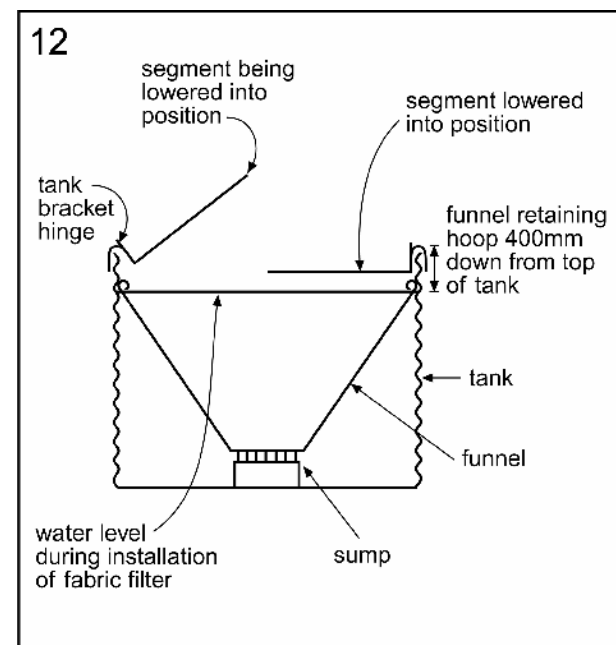

13. On each of the six tank assembly brackets, rotate the crosspiece to lock the segments in place. Assemble the central beam member by attaching the central dish support arm to it and lower this into place, making sure the central dish covers the ends of the segments and bolt the central beam onto the two tank bracket hinge assemblies. This assembly will help prevent the segments lifting in the centre of the tank when the system is in operation. [See animation Power Point](#)

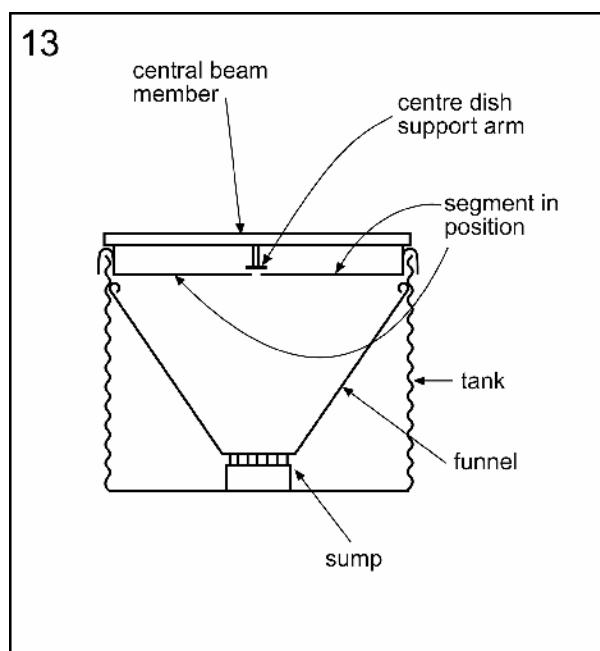

14. Install the gate valves (from the T11 tank kit) onto both inlet flanges. Into one of these valves insert the water sampling arrangement, consisting of a 3" nipple, 3" to 1/2" reducing tee, c/w with 1/2" ball valve and 1/2" hose.

The outlet flange should have a Tee fitted, which is provided with the constant head chlorine-dosing device. Then the length of discharge hose can be connected and laid out to storage tanks. (Water can be sampled at the end of the outlet hose where it enters into storage tanks.)

Attach the ball valves onto the outlet flanges for the sludge washouts, ensuring the handle in its open position is pointing away from the tank, and attach the two short lengths of layflat hose to each of these.

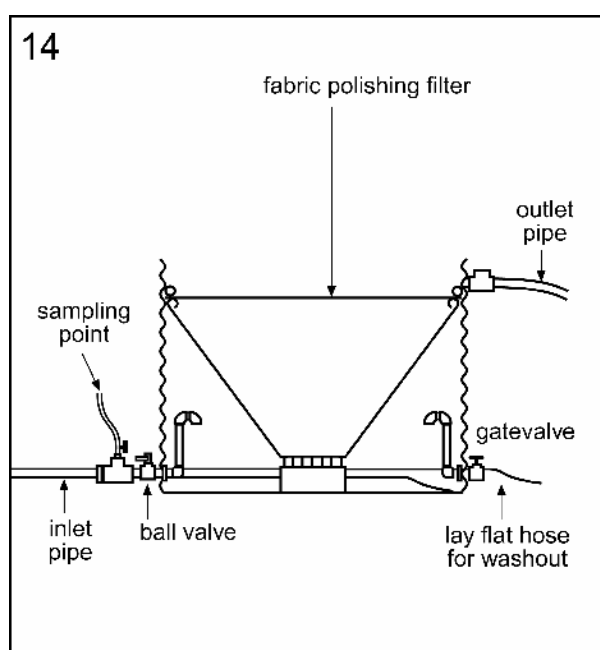

15. The 3" BSP outlet socket can be screwed into the flange. The slotted outlet pipe can be slid through the bracket attached to the central dish support arm, also through the bracket attached to the segment and pushed into the outlet socket, keeping the slots facing upwards.

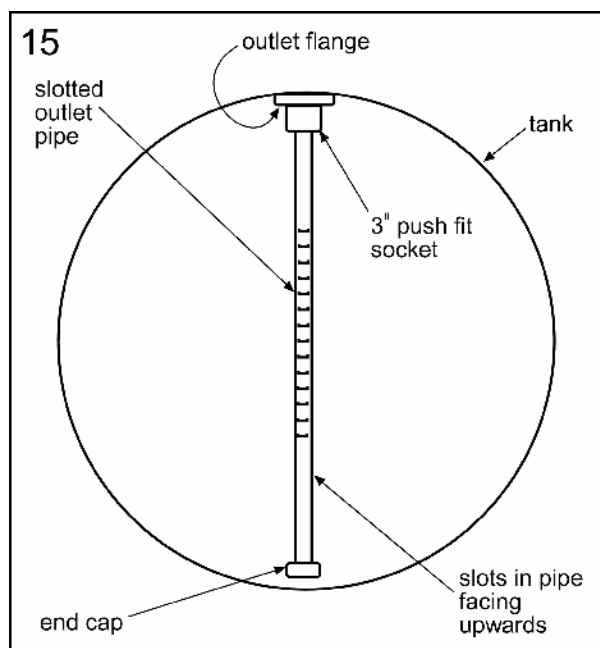

16. The eye nuts can be removed as the funnel is now fixed in position and the 24 layflat hose brackets can be bolted onto the side of the tank adjacent to the second sheet of the tank using the bolts on the horizontal joints. Enough brackets are provided to fix onto every first and second tank bolt, while every third bolt will not have bracket fixed. 48 internally threaded collars are provided to screw onto the tank bolts, where the top and bottom of the layflat crimping brackets are to be fixed to the tank. These effectively extend the length of the protruding tank bolt to allow the brackets to be securely fixed top and bottom. [See animation Power Point](#)

The adjustable face of this bracket should be removed in readiness for the hose to be installed. The two long lengths of layflat hose can be unrolled and the 3" hose connectors inserted into each end and one end of each of the layflat hoses inserted into the Tee, which should be positioned according to where the raw water will be provided from.

The layflat hose should then be wound around the tank in opposite directions using the hose brackets to "stack" the hose up the side of the tank. Finally the other ends of the hoses should be connected to the clarifier inlets. Care should be taken to ensure that layflat hose is not badly folded or crimped as this will decrease flow and increase head loss. The adjustable bracket face should be fixed in place and this tightened up to leave a gap of about 60mm which will crimp the layflat hose slightly, which assists in floc formation.

17. The constant head chlorine-dosing device should now be installed. Finally a pump (Oxfam code PR2 or P2) can be connected to the clarifier, complete with suction side dosing arrangement (diagram 1); alternatively the clarifier can be fed water from a raw water tank with aluminium sulphate doser set up (diagrams 2 and 3). The diagram opposite shows the completed tank arrangement.

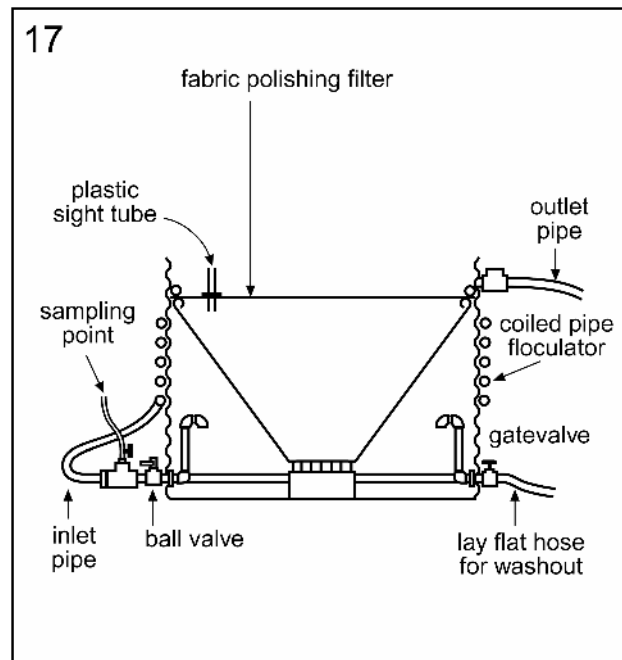
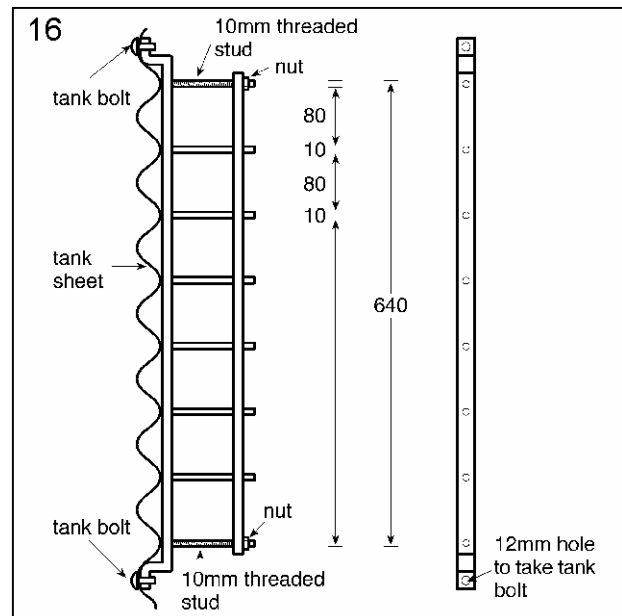

Disinfection

18. Remove constant head dosing kit (code FCCD) from packing case and knock sides off case and runners off the bottom. Make up the 2 Tee sections of frame by bolting each shorter piece to the top of the longer piece and then bolt the two tank brackets to these. Using the longer bolts, fix the packing case base to the top of the Tee sections. Slide the frame assembly onto the edge of the Oxfam tank and using the special tank bolt/nut, fix the bottom part of the bracket to two of the horizontal tank nuts. In the dosing device, insert the bucket guide and level indicator into the hole in the centre of the tank and position dosing tank on top of plywood base, ensuring the backnut on the underside of the tank fits into the hole drilled into the plywood. Flow control in the constant head dosing kit is regulated either by the valve, by the amount of ballast placed in the bucket (use plastic bags provided) or by the orifice cap size. 3mm and 5mm orifice caps are provided and these can be screwed into the pipe at the base of the bucket.

Using the self tapping screws, fix the two flow meters with on/off valve to the side of the frame. Next, using flexible hose, connect the tank outlet to whichever flow meter is required and fix a length of hose from the flow meter to the 3" Tee. This device can be either attached to the outlet of an upflow clarifier (at top of tank) or to an outlet of a water storage tank (at bottom of tank). Where onion tanks are used, the device can be floated directly on the water (as per diagram 2 above) and allowed to discharge from this position, though care will have to be taken to ensure that the correct residual time can be achieved.

19. The HTH chlorine powder (Oxfam code FCH) can be used with the constant head-dosing device (Oxfam code FCCD), which should be attached to the edge of the Oxfam tank. This device can be either attached to the outlet of an Upflow clarifier (at top of tank) or to an outlet of a water storage tank (at bottom of tank). Where onion tanks are used, the device can be floated directly on the water (as per diagram 2 above) and allowed to discharge from this position, though care will have to be taken to ensure that the correct residual time can be achieved. Alternatively, chlorine can simply be batch dosed by mixing in a bucket and added to tanks (not illustrated).

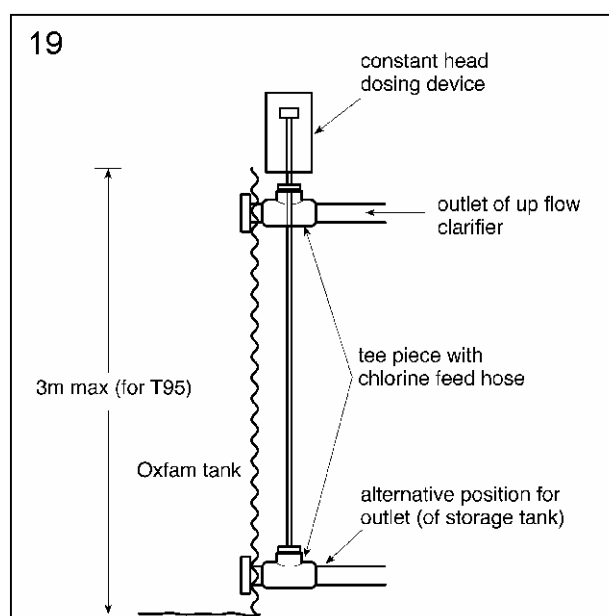
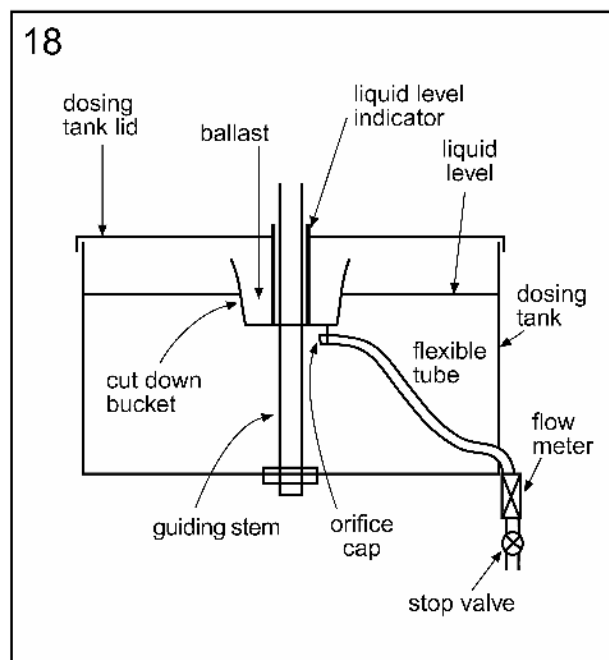

20. The floating pot chlorinators (Oxfam code FPP) are for use with the Chlorine tablets - trichloroisocyanuric acid (Oxfam code FCT) and dose rate can be adjusted by use of a “gate” for the slots on the side, as well as by varying the amount of tablets used in the pot chlorinators. Suspend the holder plus chlorine tablets in the water in a position which should give sufficient contact time to achieve a chlorine residual, but away from the turbulence caused by the inlet pipe. Initially use three tablets for a T45 tank (four for T70, five for T95). These will need replacing in 7-14 days. Check residual chlorine levels daily and adjust the number of tablets if necessary. ***It is not recommended to drink water chlorinated with these tablets for more than three months.***

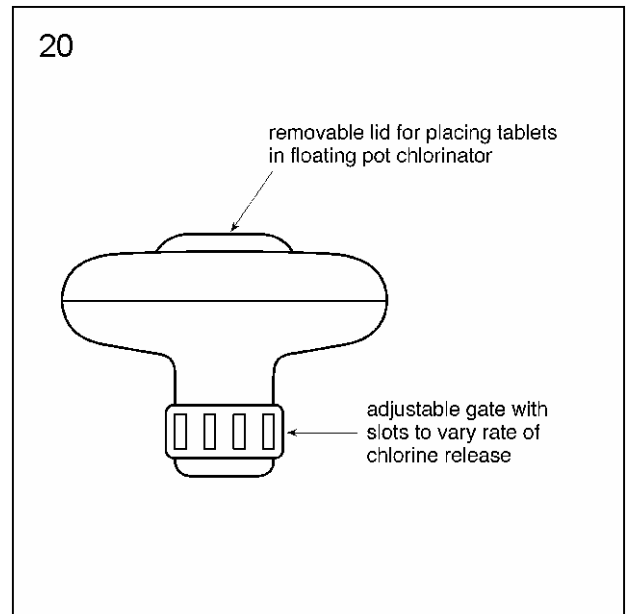

SECTION C - OPERATIONAL INFORMATION

Coagulation and flocculation

Determining the optimum dose – the Jar Test

The purpose of the jar test is to determine the correct dosing concentration for an individual application where effective flocculation is employed. Pouring a bucketful of aluminium sulphate solution into a tank of water and stirring by hand is not “effective flocculation” but is sometimes required in extreme emergencies. This will almost certainly lead to excessive aluminium sulphate residuals in the product water (WHO recommends a maximum of 0.2mg/l) although excessive aluminium should not form major threats to community health in the short term. Every water treatment application is different in terms of raw water quality, hydraulic conditions and even coagulant batch properties. Optimum conditions for good flocculation are determined not only by the optimum dose of coagulant, but also by the physical conditions of coagulant dosing and flocculator hydraulics.

Calculations can be made to design efficient flocculators, principally determining retention time and degrees of mixing. These considerations should then influence the jar test procedure adopted and these undertaken in a way to mimic conditions in the water treatment system. It has been found that a dining fork can be used to provide a stirring efficiency equal to that achieved by laboratory equipment, but it must be stressed that other cutlery and kitchen implements are not as effective for reasons related to basic hydraulics.

Procedure for undertaking a jar test;

1. Make up 1% alum solution

- A 1% alum solution is formed by dissolving 10 grams of granular alum into 1 litre of clean water (mix in less than 1 litre then make up to the final volume). This solution will be referred to as a 1% Oxfam Alum Solution. (To allow measurement by volume to be interpreted as a weight: 1 litre of granular alum weighs 1100 grams and then by use of measuring cylinder in the Oxfam code FMT kit) A baseline alum solution concentration is as follows:

1% Oxfam Alum Solution = 10,000 mg/l (10,000ppm) Alum Solution

2. Collect equipment for jar test, (as in Oxfam code FMT kit):

- Turbidity is best recorded on a turbidity meter to enable fine distinctions to be made between similarly turbid water.
- The Turbidity tube, Oxfam code FTT and as found in DelAgua kit (Oxfam code FK) does not provide accurate readings, but is probably all that is available.

Equipment required;

- 6 No.1 litre jar (beakers)
- Turbidity meter or turbidity (Jackson) Tube
- Timer or stopwatch
- Pipette or fine measuring cylinder
- Litre measuring cylinder
- Supply of 1% Oxfam Alum Solution
- Raw water sample container (at least 6.5 litres)
- Dining fork for stirring

3. Dose Jars

- Pour appropriate quantities of 1% Oxfam Alum Solution and raw water into test jars to produce the desired concentrations of coagulant.
- Initial starting concentrations of Oxfam Alum Solution in test jars is recommended as 50, 60, 70, 80, 90, 100 mg/l (i.e. 5, 6, 7, 8, 9, 10 ml of 1% Oxfam Alum Solution for each litre of raw water).

4. Stir Jars

- Stir briskly with a fork for a time equivalent to the transit time in the system (for the spiral pipe flocculator about 2 mins). Periodically stir each jar to ensure that a “whirlpool depression” is continuously visible on the centre of each test jar’s water surface.
- Stir gently for a time equivalent to the residence time of the flocculation tank (for chamber behind the funnel in the upflow clarifier typically approx. 30 mins). Periodically stir each jar to keep the emerging flocs gently moving, they should be visible in the water of every beaker, moving gently.

5. Monitor Turbidity

- Allow to briefly settle and then carefully take water samples from the top of each jar to measure turbidity.

- Take turbidity readings for each jar before commencing the test and then at test run times of 2.5, 5, 10, 15, 25 and 40 minute intervals, which requires 6 jars of each concentration to be made up.

6. Plot Results (refer to graph)

- Plot the turbidity results on an X-Y graph with Turbidity in NTU as the Y-axis (vertical) and Alum Dose in mg/l as the X-axis.
- Produce graphs on the same X-Y axes, one for each "test run time" interval (6 No.)
- The graph with a regular profile (typically "bucket shaped") and which also contains the lowest turbidity value on the Y-axis should clearly indicate the optimum coagulant concentration.
- If the highest or lowest concentration tested appears to be the optimum value, repeat the jar test for further coagulant concentrations which induce this value in the middle of the range of concentrations tested

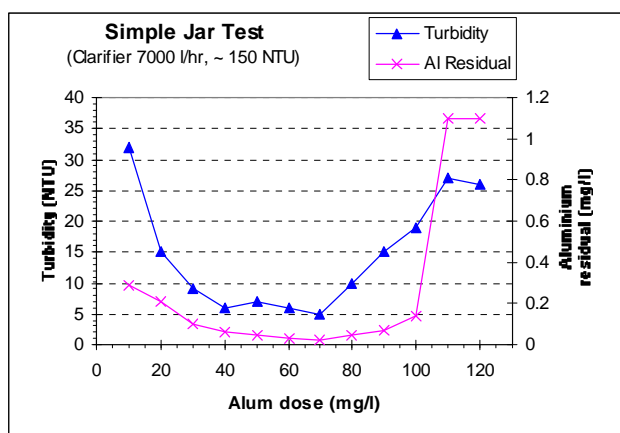

7. Uncertain Results

- Repeat the test to eliminate experimental error. Check all calculations and graph plots.
- Test pH value of the raw and product water to determine if pH adjustment is necessary. The jar test can be used to find the lime or acid dosing rates required. The resulting range of pH values should extend from 4.5 to 8.5. After stirring, flocculation and sedimentation, the optimal pH value is determined from the samples.
- If pH needs to be raised, lime should be added to keep the pH within the optimum range of 6.5-7.5 for aluminium sulphate use. Alternatively if no lime is available or for highly alkaline waters, use extra alum to compensate, but monitor alum carry over in treated water (using comparator in Oxfam code FMT kit).

- Try water treatment making a best guess for coagulant levels on the evidence available.

Dosing rates

Once the optimum dose has been established, it is then necessary to determine the actual dose rate, i.e. the rate at which aluminium sulphate solution is put into the water stream. In addition the total volume of solution that is required for the tank, which clearly depends upon tank size. The table below should give some guidance on this.

Although the jar test is conducted using a 1% solution, dosing should be made using 10% aluminium sulphate solution. This concentration may need to be raised if large volumes of water need dosing or lowered if very small quantities of aluminium sulphate solution are being used such that the rate of dosing is outside the range of the flow meter on the solution side doser. However it should be noted the while good quality grade aluminium sulphate will dissolve into water at concentrations of up to 20%, where aluminium sulphate is purchased in country and it is a poorer grade, it may be that solubility will be lower than 10% and this should be taken into account.

For a 10% alum solution

Req. dose of alum	Dose rate per 10m ³ /hr of water flow	Dose rate per 50m ³ /hr of water flow	Dose rate per 100m ³ /hr of water flow
30 mg/l	3 l/hr	15 l/hr	30 l/hr
150 mg/l	15 l/hr	75 l/hr	150 l/hr

The rate of water flow (and thus solution flow) will be greatest at maximum pump output. Details of pump output, which depends upon pumping head are given in the pumping manual, but as a guide the following maximum outputs for pumps at very low pumping heads are possible:

PR2 28 m³/hr, P2 38 m³/hr
P4/P4H 90 m³/hr

Example

The optimum dose rate for a water to be treated has been determined by jar test to be 30mg/l. A suction side doser is to be used with an Oxfam P2 pump, which is pumping into an Oxfam T70 tank, where coagulant assisted sedimentation

will occur. What flow rate should be set on the suction side doser and what total volume of alum solution is required?

A P2 pump will pump at max 38 m³/hr at zero head, so dose rate of alum will have to match this water flow rate. From the table above for a dose of 30mg/l, a dose rate of 3 l/hr is required for a 10m³/hr, i.e. 11.4l/hr for the P2 pump operating under these conditions. This will require the appropriate adjustment of the needle valve on the suction side doser and this should be set to achieve this flow by estimating the rate of discharge from the coagulant vessel on a volume basis.

The T70 tank has an effective volume of 70m³ and will require around 21 litres of 10% alum solution to dose the tank.

Coiled pipe flocculator

Floc is an insoluble metal hydroxide precipitate, produced by the reaction of the coagulant salt (alum) with hardness in the water and which incorporates colloidal or fine particles. It appears as a cloud of small "flakes" within the body of the water. A simple coil of pipe can provide the velocity gradients, (i.e. by creating a circular flow, this induces greater shear in the water and encourages better floc formation) retention times and general conditions suitable to support flocculation, although as with other methods, the raw water quality can influence the overall performance. The role of the flocculator in a treatment system is to cause collisions between particles in raw water, to which a coagulant has been added, encouraging the build up of floc.

There are only two means of effectively controlling the coiled pipe flocculator, either by adjusting the throughput rate, which affects the velocity ($Q=A.v$) or varying the length of coiled pipe, which affected the retention time. The standard design approach for a flocculator involves calculating the following: Time in flocculator t , recommended value $2 < t < 6$ minutes. The choice of two parallel lines of 75mm hose is made to keep head losses to a minimum and to ensure symmetry of operating conditions when used with the upflow clarifier. However a single line of 3" green flexible hose could be used in conjunction with a sedimentation tank. The spiral pipe flocculator is a low energy input system, often requiring a strong coagulant, but tests with

Aluminum sulphate combined with the coiled pipe flocculator have proved successful.

Sedimentation

Where water treated with a coagulant is undergoing simple sedimentation in an Oxfam or PVC tank, the system will be operated on a batch basis. A typical daily operation schedule might be as follows:

Activity	Typical duration
Pumping/gravitation of water into tank	Depends upon tank size and discharge rate of pump at tank inlet
Sedimentation	2 – 6 hours but depends upon water quality
Emptying treated water into final chlorination tanks	½ – 2 hours depending on tank size and elevation differences

Very often, it will only be possible to get two or perhaps three batches of water from each tank per day and in order to satisfy water demand it may be necessary to run two or more lines of tanks in parallel, so that one can be delivering water for chlorination while another is being filled.

Regular cleaning of the tanks to dispose of the sludge will have to be undertaken, the cleaning interval depending upon the level of sludge buildup in these tanks, which itself is dependent upon raw water quality. It may be necessary to periodically empty the tanks manually by having a person enter the tank to bale/brush floc out of the tank – operatives should be assigned Wellington boots and gloves for this task. Sludge disposal should be undertaken safely and where large volumes are being generated, separation of the floc from as much water as possible using gravel filter beds will help reduce the sludge volume and allow it to be dried before landfill disposal.

Description of upflow clarifier treatment process

It is useful to include an outline of basic functioning of the Upflow clarifier system process in order to understand how best it is operated.

Where an Upflow clarifier is used with a pump, the coagulant is introduced into the pump using the suction side dosing arrangement where

vigorous mixing occurs in the pump chamber. The next stage of the process is to pass water through the coiled flocculator, which consists of 2 parallel coils of 75mm layflat hose, each 30m long, which act as flocculators, by gently stirring the water as it passes through the coils of the pipe. The pipe is coiled around the T11 tank to provide a circular motion and to keep the pipe in a place to minimise risk of damage. Furthermore this allows the layflat hose brackets to crimp the layflat hose to induce flow patterns that also encourage better floc formation.

By the time the water enters into the T11 tank in which the upflow clarifier is built, some flocs should already be forming. Further slow mixing occurs when the flow enters the tank at the inlets and this subsequently drops down and passes between the sump and the funnel, before starting to rise again inside the funnel. As the water rises up the ever widening funnel, the velocity drops and a point will be reached whereby up-thrust on the floc will be equal to the effect of gravity, such that the floc will stop moving upward and a floc blanket will be formed at this point. As this blanket builds up, further flocs will become trapped in the underside of this blanket and it will thicken with time. Water with considerably reduced floc loading will flow out from the top of this blanket and through the fabric polishing filter, which is present to remove small amounts of floc carry over and then to the tank outlet. Eventually there will be a need to drain down the system to prevent the blanket becoming too thick.

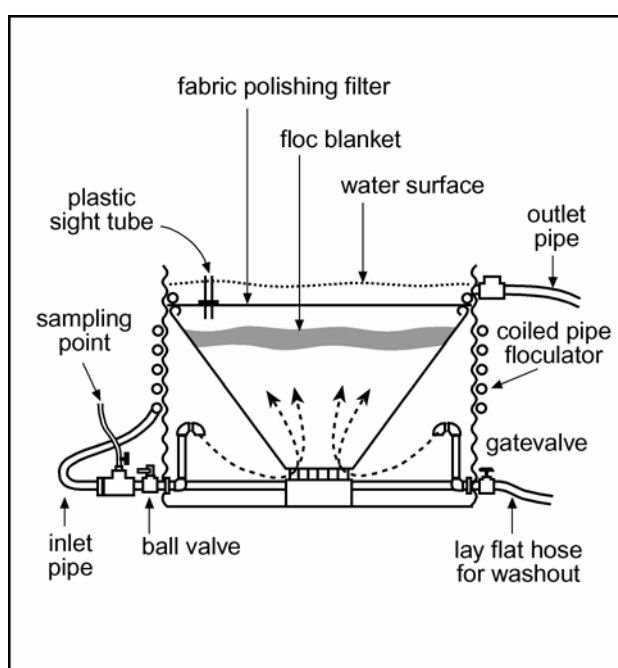

Operation of upflow clarifier

The first step in determining the best operating conditions for the clarifier is to determine the aluminium sulphate dose, by undertaking a jar test (see above). The optimum dose is dependent not only on the characteristics of the raw water, but also on the hydraulic conditions of the treatment process. Having determined the correct dose for the coagulant, then a solution of this should be made up.

Once this is established, the pump/raw water tank can be connected up to the coiled flocculator and the solution of coagulant should be dosed into the pipeline, upstream of the coiled flocculator and water run into the tank. It will take about 60 minutes to fill the tank. By the time the water level has filled the tank to the top of the tank funnel, a floc blanket should be forming. The blanket level is affected solely by the flow rate. It is suggested to start flow off at 6500 litres/hour, allowing blanket stability to be reached, before flow is increased to bring the blanket level just below the top edge of the funnel hoop. As the flocs are light and increases of flow cause surges, it will take about 1 hour for the system to run in. It is also recommended that the jar test be repeated if possible at this stage by incorporation of the actual flow and retention times and dosing rates altered accordingly if required. It should be noted that changes in raw water quality, e.g. after rains, may necessitate changes in the flows through the Upflow clarifier and indeed the dosing rate for the coagulant too.

Breakthrough of the floc blanket may be caused by too high a flow or an incorrect coagulant dose and results in high turbidities, suspended solids and residual coagulant salts in the effluent water. Visual checking of the height and condition of the blanket as flow increases is an important and simple means of assessing the situation, thus a close inspection of the water above the blanket and from samples taken from the outlet, should reveal if there is any floc carry over. If there is a significant amount, then this may necessitate reducing the throughput into the system. A smaller quantity of floc carry over will be retained on the fabric-polishing filter, in which case this can be positioned without further flow adjustment.

Where possible the upflow clarifier should be operated overnight if maximum water production is required and this may require the use of header/raw water tanks if pumps can not be operating continuously (10m³ of storage volume

is required for each hour when pumps are not operating). Where it is operated on a batch basis, then the floc blanket will have collapsed from the previous day's operation and this will need to be reformed when the system is started up again. This will require removal of the fabric filter to watch this occurring and the initial product water may need to be run to waste, before the fabric tray is replaced and water made available for supply.

Every so often the system will need desludging using the sludge outlets at the bottom of the tank (detailed investigation is currently under way to determine the operating envelope more precisely). This waste needs to be disposed of in a manner that does not contaminate water supplies or undermine stability of tank foundations. The easiest method in the short term will be to dig a suitable drainage channel to take the water off to a drainage pit, where the liquid load can be separated out from the solid flocs, these can be then be dried and disposed of by burial in plastic bags/sheeting. At longer time intervals the funnel may need removing in order to manually clean out the entire tank.

The fabric filter will need cleaning occasionally and this should be removed and thoroughly washed down with a high pressure jet of water from the pump and scrubbing motion. A second fabric filter is provided for use while the first is being cleaned and as a spare.

If clarifiers are used in the water treatment system it should be remembered that their performance improves over a "running in" period of several hours, before hastily concluding that flocculation is unsuccessful. Under optimum conditions of raw water quality, throughput flows of 7 - 9 m³/hr or more are possible. Such a system depends on operational knowledge developed under local circumstances and will vary from site to site. In addition, because of the far more effective control of flocculation, much lower metal residuals are likely to be found in the potable supplies compared to a process of sedimentation assisted with coagulants performed in Oxfam tanks.

Chlorination

The most important factor in any use of chlorine is the determination of the concentration of chlorine required in the water, which is about to be consumed by the human user. Chlorine is absorbed by all forms of organic material, which may be present in any water or on water-carrying utensils. It is vital, therefore, that enough is added to leave a residual at the end of the distribution system. Contamination, which is introduced along the distribution system, will thus be destroyed. There are many potential points of contamination or water, both before and after it has been collected by the consumer, but especially when stored in the home.

A minimal residual, of 0.2 – 0.3 mg/litre, is required at the final delivery point. But, because of the potential contamination in the distribution system, it is necessary to dose at a higher concentration of chlorine in the storage tank. This may be as high as 2-3 mg/litre or more, but will need to be determined by experiment and testing of chlorine levels through the delivery chain. After addition of chlorine, the water needs a certain amount of time (called contact time) to kill the viruses/bacteria in the water and this is usually at least 30 minutes, though sometimes longer is required (see below). Residual chlorine levels should be checked daily and chlorine dosing adjusted as necessary. The level of residual chlorine is very easily determined by use of a simple colour comparator and tablets added to the water. A chlorine comparator is available (Oxfam code FPO) or this also comes in both the Oxfam/DelAgua Water Test Kit (Oxfam code FK) and the measuring and testing kit (Oxfam code FMT).

The "contact time" is normally a minimum of 30 minutes for neutral pH waters. However, the length of contact time required for the active chlorine to be fully effective depends upon many factors of which the most important are pH and water temperature. A higher water temperature will enable the chlorine to work faster. Although most raw water sources have a pH value within the range 6.5 – 8, as the pH levels rise, the disinfecting properties of chlorine start to become weaker and at pH 9 there is very little disinfecting power.

The table below shows how higher pH values can be compensated for by either adding additional chlorine or increasing the contact time.

pH	Required chlorine residual at 20°C (mg/l)	Minimum contact time needed for effective disinfection (min)
8.0	0.5	30
8.5	0.2	206.0
	0.5	82.5
	0.8	52.0
	1.0	41.0
	1.5	27.5
9.0	0.2	412.0
	0.5	165.0
	0.8	103.0
	1.0	82.0
	1.5	55.0

Ascertaining the required dose for HTH powder

To determine how much chlorine to add, the chlorine demand is measured.

1. Prepare a 1% chlorine solution, the quantity depending upon type of chlorine used (see table below).

Quantities of Chemical required to make 1 Litre of 1% Chlorine Solution

Source of chlorine	Available chlorine %	Quantity required (g)
Bleaching powder	34	30 - 40
HTH	70	14
Tropical bleach	34	25
Stabilised bleach (Stabochlor)	25	40

2. Take 3 or 4 non-metallic containers of known volume (e.g. 20l buckets).

3. Fill the containers with some of the water to be treated and check the pH of the water.

4. Add to each bucket a progressively greater dose of 1% solution with a syringe:

1st container: 1ml

2nd container: 1.5ml

3rd container: 2ml

4th container: 2.5ml

5. Wait 30 minutes (essential: this is the minimum contact time for the chlorine to react. If the pH of the water is high, this minimum time will increase).

6. Measure the free chlorine residual in each bucket.

7. Choose the sample which shows a free residual chlorine level between 0.2 and 0.5mg/l.

8. Extrapolate the 1% dose to the volume of water to be treated.

9. Pour the solution into the reservoir/dosing vessel, mix well (during filling) and wait 30 minutes before distributing to consumers.

10. Check chlorine demand at several water distribution points and adjust if required.

11. Recheck chlorine demand periodically and when raw water quality is known to vary, to ensure that the chlorine residual is maintained.

Example for Chlorination of water in a 2,000l reservoir

Follow steps 1-5 above.

The free residual chlorine levels of the water in the buckets, measured half an hour after adding 1, 1.5, 2 and 2.5ml of 1% chlorine solution respectively are as follows:

1: 0 mg/l

2: 0.1 mg/l

3: 0.4 mg/l

4: 1 mg/l

The dosing rate chosen therefore will be that for bucket number 3 (result between 0.2 and 0.5mg/l). Thus if it needs 2ml of 1% solution to chlorinate 20l of water at the correct dosage, then it needs 100 times as much to chlorinate 2,000l, i.e. 100 x 2ml = 200ml of 1% chlorine solution.

Note

- The taste of chlorine in water is no proof of the presence of free residual chlorine (it could be combined residual chlorine).
- Metal consumes chlorine, so never prepare strong solutions in metal containers (unless they are enameled or painted).

Dose for use of slow dissolving tablets

Chlorine tablets (Oxfam code FCT), containing trichloroisocyanuric acid, can be used in the following quantities 3,4 or 5 tablets (for T45, 70 and 95m³ tank sizes) and should last for 7-14 days, assuming the tanks are filled once daily, depending on water quality see table below.

1	200 gramme tablet will treat 36,000 litres/day at 5ppm
2-3	200 gramme tablets will treat 45,000 litres/day at 1ppm
3-5	200 gramme tablets will treat 70,000 litres/day at 1ppm
4-7	200 gramme tablets will treat 95,000 litres/day at 1ppm

Safety when using chlorine

All forms of chlorine used as water disinfectants can be dangerous if not stored and handled in the correct manner.

The following simple rules must always be followed and any particular advice and precaution supplied with a specific product should likewise be closely followed;

- Only trained and authorised personnel should be allowed into the chlorine store
- Chlorine is caustic, i.e. can cause burning and must not come into contact with skin or clothing. Thus protective clothing such as gloves, goggles and overalls or apron is advisable
- Chlorine should be stored under dry, cool dark conditions, preferably raised above ground. Keep all containers closed and covered with a tight fitting lid when not in use.
- Avoid breathing chlorine dust as it is an irritant to the nose and lungs.

SECTION D – DETAILS OF KITS AND SUPPLIERS

Full list of kit contents

Alum suction side dosing kit, 2" pumps

Oxfam code FASD

(approximate gross weight 86 kg and volume 0.82 m³), containing:

Item	Qty	Description
1	1	210 litre MDPE round tank with lid fitted with an internal filter, bulkhead fitting, outlet located in bottom of tank and on/off valve fitted to outlet ending in 12mm hosetail.
2	1	2 m of 12mm dia clear flexible pipe, c/w 4 jubilee clips
3	2	½" (M) BSP to 12 mm brass hose tail
4	1	Georg Fischer (or equivalent) needle valve type sk323, with Vee notch and ½" BSP (M) thread and 12mm hosetail.
5	1	1" (M) to ½" (M) reducing nipple
6	1	½" (F) galvanised elbow
7	1	4" (F) to 1" (F) galvanised reducing Tee
8	1	4" BSP (F) brass flow control valve
9	1	4" galvanised nipple
10	2	4" to 3" galvanised reducing nipples (M)
11	2	4" to 2" galvanised reducing nipples (M)
12	2	4" BSP (M) maleable iron hose couplings, c/w hose clips
13	2	3" BSP (F) maleable iron hose couplings, c/w hose clips
14	2	2" BSP (F) maleable iron hose couplings, c/w hose clips
15	2	Rolls PTFE tape
16	1	25kg sack of aluminium sulphate
17	1	Copy of Oxfam Coagulation and Disinfection equipment Manual (Oxfam Code FCM) in grip seal water proof plastic bag

Chlorine constant rate dosing kit

Oxfam code FCCD

(approximate gross weight 25kg and volume 0.28m³), containing:

Item	Qty	Description
1	1	100 litre tank, 600 x 400 x 400 deep, with ½" outlet c/w valve, in side of tank, 25mm up from the bottom.
2	1	Constant head dosing device, made from cut down 270mm bucket, with 12mm (internal Ø vacuum hose (7 bar pressure resistant) fixed to underside of the bucket.
3	2	Orifice caps to fit over end of 12mm hose, 1 with 3mm hole and 1 with 5mm hole drilled in centre.
4	2	flow meters to cover flow range of 2.5 – 25l/hr, 1 for chlorine dosing and other for aluminium sulphate dosing
5	1	Plywood dosing tank platform, made from kit box.
6	4m	12mm (internal Ø vacuum hose (7 bar pressure resistant) to connect dosing device to either high or low level tank

		outlet.
7	1	Frame to mount dosing device onto side of 2.6m tank (T11) or 6.4m tank (T45/70/95), made from 85mm x 30mm galvanised purlin.
8	1	3" – 2" reducing Tee (F)
9	1	2" M to ½" F reducing bush
10	1	½" BSP cable gland
11	4	Plastic jiffy bags for soil ballast
12	1	Copy of Oxfam Coagulation and Disinfection equipment Manual

Upflow clarifier (to fit T11 tank)

Oxfam code FUC

(approximate gross weight 315kg and volume 1.05m³), containing:

Item	Qty	Description
Cone and sump arrangement;		
1.	1	Cylindrical central steel sump, 600mm diameter x 250mm high, with 3 No steel sockets, 80mm long to provide clearance fit over 3" steel pipes, welded onto outside of sump with centre of holes 125mm from base. 19 No 10-mm diameter holes spaced equidistant around sump, to be drilled in sump, 15mm down from lip of sump to centre of hole. Sump base to have beveled edge (to avoid liner damage).
2.	1	0.91mm thick scrim reinforced PVC upflow clarifier funnel, all welded construction, to fit inside Oxfam 2.6m diameter T11 tank. Funnel to consist of two parts joined together: a) Cone to be 600mm diameter at bottom, widening to 2.6m diameter at the top, with a cone depth of 1.5m. Bottom of cone to have 19 eyelets UV bonded into hem, positioned 25mm from edge. Hem to be doubled up to provide extra strength. 2.6m diameter, with one edge welded onto the larger end of the cone and other end provided with 36 eyelets UV bonded into hem, positioned 25mm from edge. Hem to be doubled up to provide extra strength.
3.	19	6mm barrel strainers, with 50mm length barrel body, for use in tightening bottom of cone to sump.
4.	36	450mm long elastic (Bungy type) strap with toggle on each end.
5.	1	PVC repair kit for repairing damages to cone.
6.	4	2000mm lengths 50mm dia PE pipe to form quadrants of hoop, and marked "cone".
7.	1	1000mm length 50mm dia PE pipe for cutting up to cover threads of rod when positioned
8.	4	300mm lengths of 25mm dia solid PVC threaded rod
9.	8	Nuts to fit 25mm dia PVC threaded rod
Fabric polishing filter:		

10.	4	1 layer of Fibertex F4-M, 4.5m diameter.
11.	1	Assembly consisting of 1 No 1" Ø clear plastic sight tube 500m long and 1" Ø plastic tank outlet, with threaded tube with internal "O" ring and 2 No lock nuts and rubber washers
12.	5	Tubular steel painted segments infilled with 25mm x 50mm weldmesh ring screen.
13.	1	As above but fitted with support bracket for outtake pipework
14.	12	0.75" x 265mm steel tubes threaded male BSP one end and with an eye welded to the other.
15.	2	Tank bracket hinge assemblies complete with attachment for overhead beam.
16.	4	Tank bracket hinge assembly
17.	8	M16 x M10 stud bushes
18.	8	M16 nuts
19.	8	M16 washers
20.	1	Central beam member c/w bracket to accept centre dish support arm
21.	2	Side beam members
22.	4	M10 bolts
23.	4	M10 nuts
24.	4	M10 washers
25.	1	400mm diameter centre dish with support arm fitted with bracket to support outtake tube
26.	1	75mm pipe clip
Coiled flocculators		
27.	2	Layflat hose 32m continuous rolls of 80mm diameter pipe
28.	5	3" BSP (M) Hose connector malleable iron
29.	10	3" jubilee hose clip
30.	1	3" galvanised Tee (F)
31.	1	3" (M) – 2" (M) reducing bush GI
32.	1	2" (F) Hose connector malleable iron
33.	1	2" jubilee hose clip
34.	24	Adjustable layflat hose "crimping" brackets, with 7 "shelves" large enough to accommodate 80mm layflat hose. Brackets to be fixed to tank bolts on horizontal joints between first/second and second/third tank sheets, at 350 centre to centre. Adjustable clamp face to be detachable and facing outwards to allow positioning of layflat hose and subsequent clamping of hose. Clamp face to be tightened by 3 threaded studs, at top, centre and bottom.
Sludge drain outlet pipe work consisting of:		
35.	2	3" Galvanised steel tube threaded each end, 425mm long, for drain outlet.
36.	2	3" galvanised Tee (F)
37.	2	3" galvanised steel tube threaded one end, 425mm long, end to extend from Tee into steel socket in sump
38.	2	3" BSP (M) Hose connector malleable iron
39.	2	3" jubilee hose clip
40.	2	4m long 80mm layflat hose to fit 3" hose coupler
Inlet pipe work consisting of:		
41.	2	90mm Ø OD compression x 3" Ø BSP (M) threaded coupler
42.	2	90mm Ø OD PVC 500mm long straight

		pipe, with 2 No 90mm Ø OD 90° elbows, for down turned inlet arrangement, solvent cemented onto one end, (for vertical part of clarifier inlets)
43.	1	3" BSP nipple GS
44.	1	3" BSP F to ½" M reducing Tee GS
45.	1	½" BSP F brass ball valve sampling tap
46.	1	½" BSP M to ½" brass hosetail connector
47.	1m	½" dia hose to fit over hosetail connector
48.	2	Table D/E flange welded to 90mm long 3" Ø pipe threaded 40mm. 4 holes drilled for M16 bolts and 4 holes threaded for M16 studs. Weld shoulder not to exceed 6mm x 6mm (to fit with 3" F threaded flanges welded onto elbow, item 46).
49.	2	3" Galvanised steel M x F 90° elbow welded into inlet flanges.
50.	8	M16 Ø steel studs 100mm long each complete with 2 x M16 Hex full nuts and 2 x M16 washers Type B (thin).
51.	4	3" Ø BS Table D/E full face synthetic rubber gaskets with 4 holes.
52.	2	3" Ø BSP (F) brass ball valves
Outlet arrangement:		
53.	1	75mm OD PVC slotted pipe 2.55m long (supplied in 2 x 1.275m lengths for packing) with one end to fit into push fit socket fixed to outlet flange and other end to fit end cap. 90 No slots at 1mm wide, (enough to take flow of 10m ³ /hr), with slots on top third of pipe, starting 0.15m in from end of the pipe.
54.	1	75mm end cap to fit above
55.	1	3" BSP M – 75mm push fit F socket to screw into flange to receive slotted pipe.
56.	2	3" galvanised nipple GS
57.	10m	80mm layflat hose to fit 3" hose coupler
58.	1	3" BSP (M) Hose connector malleable iron
59.	1	3" jubilee clip
60.	1	Roll 6mm diameter x 220m long poly rope
61.	1	Special metal tool for inserting into eyelets of funnel to pull into position.
62.		Pole/broom handle (for pushing up funnel while installing in tank).
63.	1	Copy of Oxfam Coagulation and Disinfection Equipment Manual (Oxfam Code FCM) in grip seal water proof plastic bag

Measuring and Testing Kit**Oxfam code FMT**

Item	Qty	Description
1.	3	Pooltester for both pH and Chlorine testing, with 500 DPD No1 tablets, 50 DPD No3 tablets, 50 Phenol red tablets.
2.	1	Checkit for aluminium range 0 - 0.5mg/l, with reagents for 130 tests (e.g. Lovibond AF520 or similar).
3.	1	Checkit for total iron (II + III), range 0 - 10mg/l, with reagents for 30 tests (e.g. Lovibond AF524 or similar).
4.	1	pH checker, range 0-14 c/w tablets for calibration (e.g. Whatman catalogue number 6602 3650 or similar).
5.	1	TDS sensor, high range 100 - 10,000 ppm (e.g. Palintest stick meter or similar).
6.	1	Thermometer, range -10 to +50oC (spirit filled, non-hazardous) c/w protective tube/case.
7.	1	Turbidity tube (e.g. Palintest PT513 - 26" two part or similar).
8.	1	6.5cm diameter plastic funnel, (plastic to be resistant to sodium and calcium hypochlorite solutions).
9.	1	50ml plastic measuring cylinder (plastic to be resistant to sodium and calcium hypochlorite solutions).
10.	6	1000ml plastic beakers, with 100ml graduations (plastic to be resistant to sodium and calcium hypochlorite solutions).
11.	10	100ml plastic sample bottles, with 10ml graduations (plastic to be resistant to sodium and calcium hypochlorite solutions).
12.	3	10ml plastic syringe with 1ml graduations (plastic to be resistant to sodium and calcium hypochlorite solutions).
13.	4	9 litre buckets with lids, with 1 litre graduations (plastic to be resistant to sodium and calcium hypochlorite solutions).
14.	2	0.3m long plastic stirring rods.
15.	2	Stainless steel dining forks (as per kitchen use).
16.	1	Stop watch, (Casio HS5 or similar).
17.	1	Copy of "Oxfam Water test kits support Manual".

Floating pot chlorinator kit**Oxfam code FFP**

(approximate gross weight 2kg and volume 0.03m³), containing:

Item	Qty	Description
1	3	Floating tablet holders
2	1	Chlorine testing kit, range 0.1 to 1.0 mg/l (pooltester)

HTH Chlorine powder**Oxfam code FCH**

(approximate gross weight 10kg and volume 0.02m³), containing:

10kg of HTH chlorine powder

Chlorine Tablets (Trichloroisocyanuric acid)**Oxfam code FCT**

(approximate gross weight 10kg and volume 0.02m³), containing:

50 x 200g slow dissolving chlorine tablets

The following items are not stocked by Oxfam

Electrolytic sodium hypochlorite generator**Oxfam code FEG**

The ChlorSet generator continuously produces sodium hypochlorite with a maximum output of 2 Kg available chlorine per day

Item	Qty	Description
1	1	Salt tank c/w lid cap and tipper (green)
2	1	Brine tank fitted with outlet hose (with blue wash inside which should be removed before installing) (green)
3	1	Electrolyser tank c/w lid electrode assemblies, cable connections and power leads (green)
4	1	Base stand and upright (silver) complete with flow stop solenoid
5	1	Rectifier panel (orange)
6	1	Copper earth spike
7	1	Zero head tank assembly c/w loose wall mounting bracket inside (black)
8	1	Box of parts for pressurised operation containing filter/regulator with hose and 4 inlet drippers, sizes A, B, C and D.
9	1	Box of accessories containing; Hi volt guard, Input voltage regulator (Sollatek AVR500) Extension lead, Surge (lightening) arrester with power feed lead fitted with consumer (kettle) connector and power supply lead fitted with 13 amp plug, Measuring bucket, Sodium hypochlorite test kit (Lovibond) Spirit level, Operating and maintenance manual
10	3	25 kg salt
11	1	Test kit containing 250 acidifying and potassium iodide tablets

Chlorine/aluminum sulphate dosing pump **Oxfam code FDO**

This dosing pump can be used to add a variety of volumes of a chemical solution to water flow on a proportional basis. As the volume of chemical (Oxfam often uses chlorine which is typically dosed at 1 – 5mg/l or aluminium sulphate which is typically dosed at 30 – 150mg/l) needed to be added depends upon % strength of the chemical solution and dose rate, the actual volume of chemical solution to be added varies considerably. Hence it will be necessary to use one of a variety of dosing heads that comes with this kit.

Item	Qty	Description
1	1	MSR H302G dosing pump
2	1	Dosing head for 0.01 – 0.12% range
3	1	Dosing head for 0.1 – 1% range
4	1	Dosing head for 1- 10 % range
5	1	Set of spares
6	1	Set of Galvanised steel pipework to be able to fit this dosing pump with its 1 ¼" inlet/outlet in series with 3" pipework. This should start and finish with 3" valve in main line water flow, 1 valve either side of doser pump (for protection of doser) and 3" flow meter on main line and ¾" flow meter on branch line with doser pump on.

Re-ordering

If it is necessary to re-order individual items, please describe them as specified in the contents list and quote the name and code number of the kit in which the item occurs.

Vector/chemical safety outfit (for 2 people) **Oxfam code XSO**

Item	Qty	Description
1	2	Face Shield
2	2	Pair of Goggles
3	10	Disposable Face Mask
4	2	Disposable polypropylene coated overall
5	2	Pair of nitrile Gloves
6	2	Saranex Apron

List of Suppliers **(based in the United Kingdom)**

The aluminium sulphate, code FAS is supplied by;

Laporte Absorbents, P O Box 2, Moorfield Road, Widnes, Cheshire. WA8 0JU

Tel: (0)151 4952222 Fax: (0)151 4952432

The alum dosing kit, code FASD, the electrolytic sodium hypochlorite generator Code FEG is supplied by

PumpSets Ltd, PO Box 1615, Andover, Hampshire, SP10 5NP

Tel: 01264 333737 Fax: 01264 333108

The chlorine kits, code FCH and FCT are supplied by;

Arch Chemicals. Site 7, Kidderminster Road, Cutnall Green, Droitwich, Worcestershire WR9 0NS

Tel: (0)1299 853112 Fax: (0)1299 851378

The Water Chlorination Kit, code FFP, is supplied by:

James White Pools Ltd, Lafford & Leavey, Garden Centre, Arrowhead Road, Theale, Reading, R7 4AZ. Tel (0)734 305000, Fax (0)734 304160.

The Upflow clarifier kit, code FUC, chlorine constant head dosing kit code FCCD, are supplied by:

Even Products Ltd, Oxtalls Farm, Evesham, Worcs, WR11 4TS

Tel (01386) 41212 Fax (01386) 765404

The Chlorine/aluminum sulphate dosing pump, code FDO is supplied by:

Phoenix instrumentation Ltd, the old Brewery, 10 Clifton Road, Shefford, Beds, SG17 5AE

Tel/fax 01462 851747

The vector control outfit, code XSO is supplied by:

Allman, Birdham Road, Chichester, West Sussex, PO20 7BT

Tel: (0)1243 512511 Fax: (0)1243 511171